



Strut systems

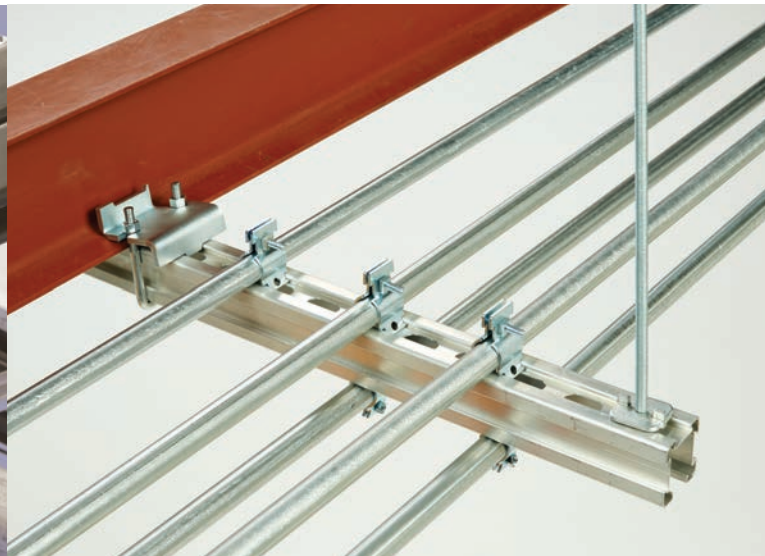

Table of Contents

Eaton is a leading manufacturer and fabricator of steel and aluminum B-Line series products which are used in support of equipment for industrial, commercial, utility, and OEM installations. We are proud of the exacting standards of research, design, engineering, and manufacturing that go into each and every product that comprise our strut product line. Our customers have access to one of the most complete support systems offered in the industry, including metal framing, cable tray, pipe hangers, slotted angle, and fasteners.

Many of our products are listed by the Underwriter’s Laboratories, Inc. All of our strut system products are manufactured to meet or exceed Metal Framing Manufacturers Association (MFMA) and other industry standards set for their design and manufacture.

Eaton’s B-Line Division
 509 West Monroe Street
 Highland, Illinois 62249-0326
 Phone: 800-851-7415
www.eaton.com/blineseries



Metal Framing Manufacturers Association

NOTICE

Eaton’s B-Line Division reserves the right to change the specifications, materials, equipment, prices or the availability of products at any time without prior notice. While every effort has been made to assure the accuracy of information contained in this catalog at the time of publication, we are not responsible for inaccuracies resulting from undetected errors or omissions.

Introduction	4 - 5
Technical Data	
Materials & Finishes	6 - 8
Welding & Corrosion	9 - 11
Design of Strut Systems & Recommended Specification	12 - 15



4Dimension™ Strut	
Information	16
CoSPEC™ Specifier Center	17
4Dimension Applications	18 - 19
4Dimension Channels Specifications & Selection Charts	20 - 21
4D22 Channel Section Properties & Load Charts	22 - 25
4D21 Channel Section Properties & Load Charts	26 - 29
Accessories	
Discontinued Dove-Tail Bars	30
Dual Dove-Tail Nut, Back-To-Back Snap On Clamp	31
Channel Nut Selection Guide	32
Dove-Tail Twirl-Nut™, Dove-Tail Slide-In Nut	33
Discontinued Wire Weld Channel Nut, Dove-Tail Combo Nut Washer	34
Combo Nut Washer, Spring Nut	35
Spring Nut w/o Spring, Twirl-Nut™	36
Universal Pipe Clamps	37 - 39
Flip Clip™ Trapeze Hanger	40
2-Piece Turn & Lock Trapeze Hanger	41
2-Piece Strengthening Clamp	42
Post Bases for 4D22 & 4D21	43
Universal Beam Clamps	44 - 45
End Caps	45
4Dimension Photos	46
Hydraulic Cutter (also compatible with several traditional strut profiles)	47

For additional information on Tolco™ brand part numbers beginning with Fig., visit www.cooperblines.com/tolco.

Table of Contents

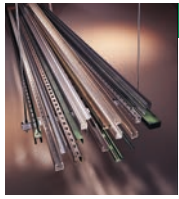

Channel & Combinations

Info. & Specifications & Selection Chart	48 - 49
B11 Channel	50 - 51
B12 Channel	52 - 53
B22, B24, Channels	54 - 61
B32 Channel	62 - 63
B42 Channel	64 - 65
B52, B54, Channels	66 - 71
Telescoping Channel	72 - 73
Channel Hole Patterns	74 - 76
Channel Closure Strips	77

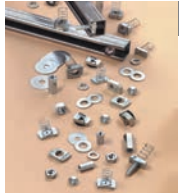

Channel Nuts & Hardware

Info. & Specifications	78
Channel Nuts Selection Charts	79 - 83
Channel Nuts Slip & Pull-out Load Charts	84 - 85
Other Hardware	86 - 92
KwikWire™ & Accessories	93 - 104



Strut Fittings

Info. & Specifications	106
Flat Plate Fittings	107 - 109
90° Angle Fittings	110 - 115
Angular Fittings	116 - 118
Miscellaneous Seismic Fittings	119 - 125
Braces	126
Clevis Fittings	127
U-Fittings	128 - 131
Z-Fittings	132 - 134
Wing Fittings	134 - 137
Post Bases	137 - 139
Brackets	139 - 147
Miscellaneous Fittings	148 - 153



Beam Clamps & Accessories

Info. & Specifications	154
Beam Clamps & Accessories	155 - 167

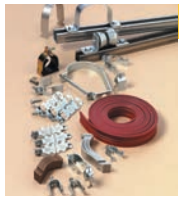

Pipe/Conduit Clamps & Hangers

Info. & Specifications	168
Pipe Clamps & Vibra Clamps	169 - 179
Armafix™ Clamps & Accessories	180
Vibra Cushions	181
Pipe Clamps, Hangers, & Brackets	182 - 189
Pipe Block & Rollers	190 - 195



DURA-BLOK™ Rooftop Supports

Info. & Specifications	196
Base Support - With & Without Channel	197
Base Support - Pipe/Tubing Riser	198
Base Support Riser - Channel & Pipe Roller	199
Base Support - 'H' Stand	200 - 201
Base Support - Pipe Roller	202
Application & Roof-Top Walkway Photos	203 - 205



206 Electrical Accessories

Info. & Specifications 206
 Selection Chart 207
 Fluorescent Fixture Hangers 208 - 210
 Electrical Accessories 211 - 212
 Junction Boxes & Strut Joiners 213 - 215
 Electrical Hardware & Porcelain Saddles 216
 Insulclamp™ Cable Clamps 217



Aluminum & Stainless Steel Materials

Info. & Specifications 218
 Aluminum 219 - 221
 Stainless Steel 222 - 223



Fiberglass Materials

Info. & Specifications 224 - 225
 Channels 226 - 229
 Hardware 230 - 231
 Fittings 232 - 241



Mini Channel & Fittings

Info. & Specifications 242
 Mini Channels & Channel Nuts 243 - 245
 Mini Fittings 245 - 253



Concrete Inserts

Info. & Specifications 254 - 255
 Continuous Inserts 256 - 258
 Spot Inserts 259
 Insert Accessories 260
 Anchors 261 - 269



Slotted Angle

Info. & Specifications 270
 Slotted Angle Sizes 271
 Slotted Angle Loading Charts 272 - 274
 Slotted Angle Fittings 275

Reference Data 276 - 285

Tolco to B-Line Cross 286 - 289

Index 290 - 298

Strut Applications 299 - 304

For additional information on Tolco™ brand part numbers beginning with Fig., visit www.cooperblineline.com/tolco.

Introduction

Our strut support system is designed with many time-saving features. They are fully adjustable and reusable, with a complete line of channels, fittings and accessories for multi-purpose applications.

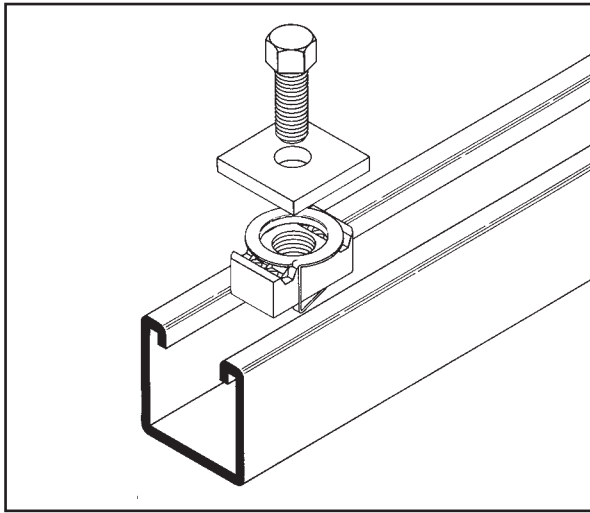

- **No Welding**
- **No Drilling**
- **Use Your Imagination**

The strut system installs quickly, with no need for special tools. All you need is a wrench and hacksaw.

Channels and parts can be taken apart for reuse as quickly as they were assembled, yet help provide the strength of welded construction. This eliminates welding and drilling which can have substantial savings in time and labor.

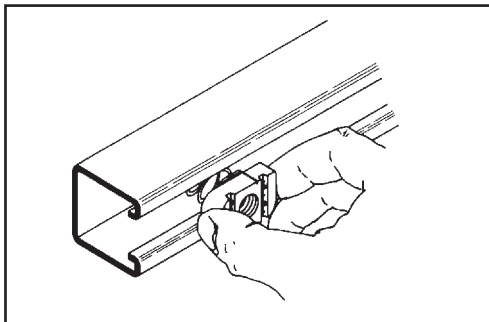

1. Channel nut may be inserted anywhere along continuous slot. Designed for easy insertion and self-alignment.

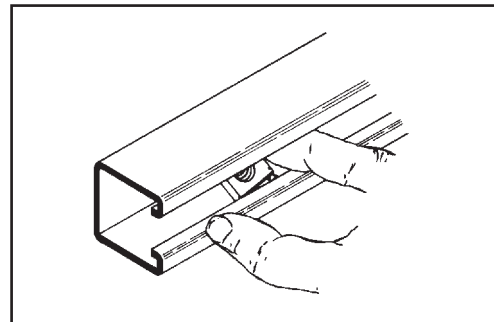

2. A 90° turn aligns channel nut grooves with inturned lips of the channel.

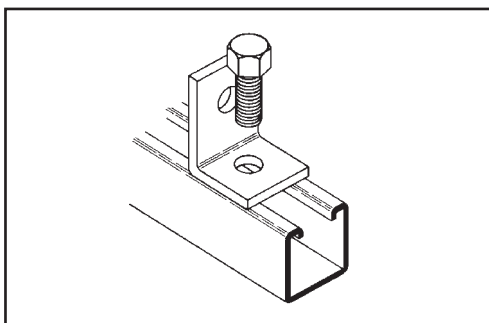

3. Position fitting over channel nut and insert bolt to start any connection.

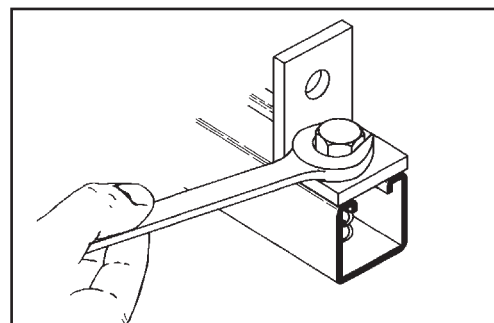

4. With the twist of a wrench, channel nut locks its teeth firmly against inturned lips.

Our strut system provides an economical solution for electrical, mechanical and industrial supports with an unlimited variety of applications in the construction industry.

Electrical Applications

- Lighting Fixture Supports
- Raceway Systems
- Trapeze Hangers
- Pipe & Conduit Supports
- Cable Tray Supports
- Beam Adjustments

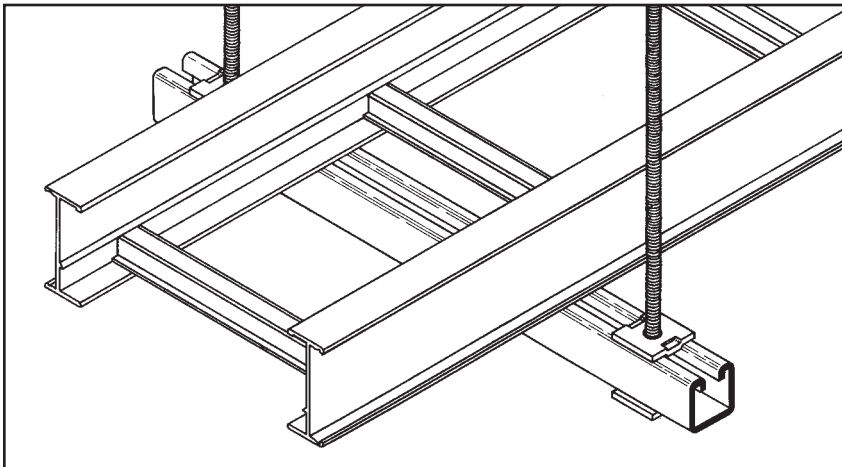
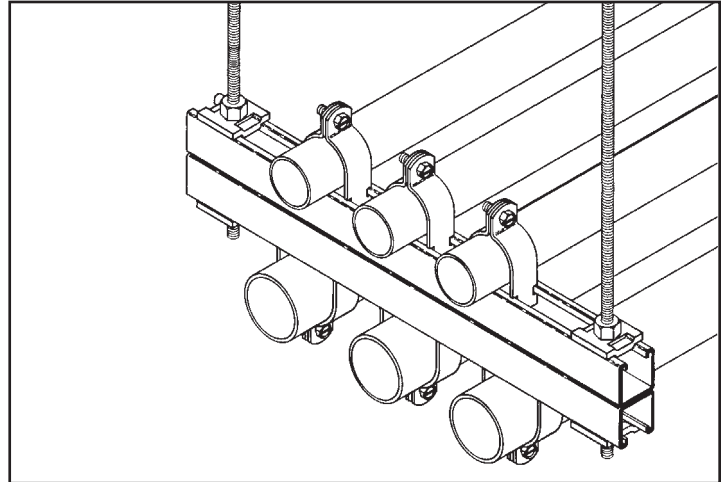

Mechanical Applications

- Piping Racks
- Tunnel Pipe Stanchions
- Concrete Inserts
- Beam Attachments
- Pipe Risers

Industrial Applications

- Racks and Shelving
- Partitions
- Production Line Supports
- Trolley Systems
- Wall Framing

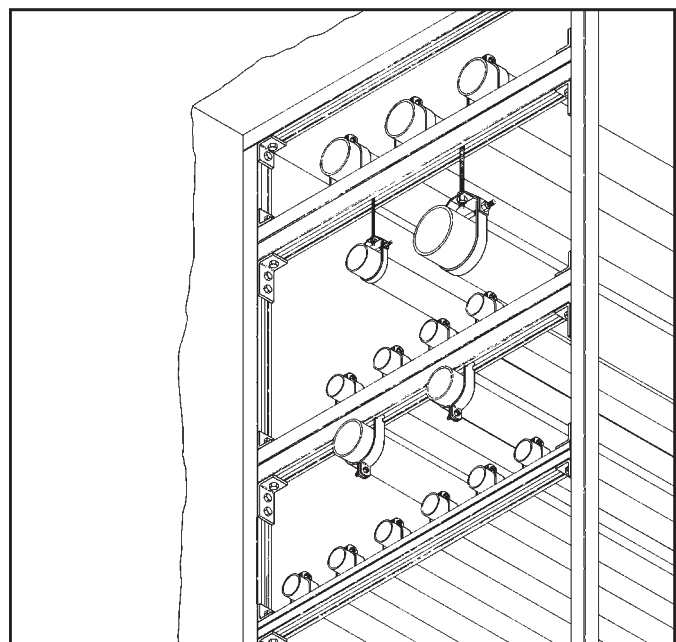

Materials

Carbon Steel

Channels made from high-quality carbon steel are continuously roll formed to precise dimensions. By cold working the steel mechanical properties are increased, allowing lightweight structures to carry the required load. Corrosion resistance of carbon steel varies widely with coating and alloy. See "Finishes" for more detailed information.

Stainless Steel

Stainless steel channel is available in AISI Type 304 or 316 material. Both are non-magnetic and belong to the austenitic stainless steels group, based on alloy content and crystallographic structure. Like carbon steel, stainless steel exhibits increased strength when cold worked by roll-forming.

Several conditions make the use of stainless steel ideal. These include reducing long term maintenance costs, high ambient temperatures, appearance, and stable structural properties such as yield strength, and high creep strength.

Type 304 resists most organic chemicals, dyestuffs and a wide variety of inorganic chemicals at elevated or cryogenic temperatures. Type 316 contains slightly more nickel and adds molybdenum to give it better corrosion resistance in chloride and sulfuric acid environments. For more information concerning the differences between types 304 and 316, visit www.bline.com.

Aluminum

Standard aluminum channel is extruded from aluminum alloy 6063-T6. Strut fittings are made from aluminum alloy 5052-H32.

The high strength to weight ratio of channel made of aluminum helps greatly reduce the overall cost of installation through ease of handling and field cutting.

Aluminum owes its excellent corrosion resistance to its ability to form an aluminum oxide film that immediately reforms when scratched or cut. In most outdoor applications, aluminum has excellent resistance to "weathering". The resistance to chemicals, indoor or outdoor, can best be determined by tests conducted by the user with exposure to the specific conditions for which it is intended. The corrosion resistance of aluminum to some commonly known chemicals is shown in the Corrosion Chart on page 10. For further information, contact us or the Aluminum Association.

Fiberglass

We offer two fire retardant (FR) resins for strut systems, polyester and vinyl ester. Both resins are ideal for corrosive environments or nonconductive applications with moderate strength requirements. Some common types of environments where Vinyl Ester Resins are recommended, that Poly Esters are not, are paper mills, most any metal plating operation and any condition with

concentrated levels of Chlorine, [Cl⁻]. Please consult our fiberglass corrosion resistance charts on page 184 for specific chemical recommendation data.

Unlike other base materials depicted in this catalog, fiberglass exhibits unique physical property changes when operating in elevated temperature conditions that are a fraction of increase compared to steel or aluminum. Thus, it is advised against using fiberglass in temperatures greater than 200° F.

Please refer to the "Corrosion Resistance Guide" on page 184 for specific applications.

The fiberglass strut systems are manufactured from glass fiber-reinforced plastic shapes that meet ASTM E-84, Class 1 Flame Rating and self-extinguishing requirements of ASTM D-635. A surface veil is applied during pultrusion to insure a resin-rich surface and ultraviolet resistance.

While polyester is sufficient for most uses, vinyl ester is suitable for a broader range of environments.

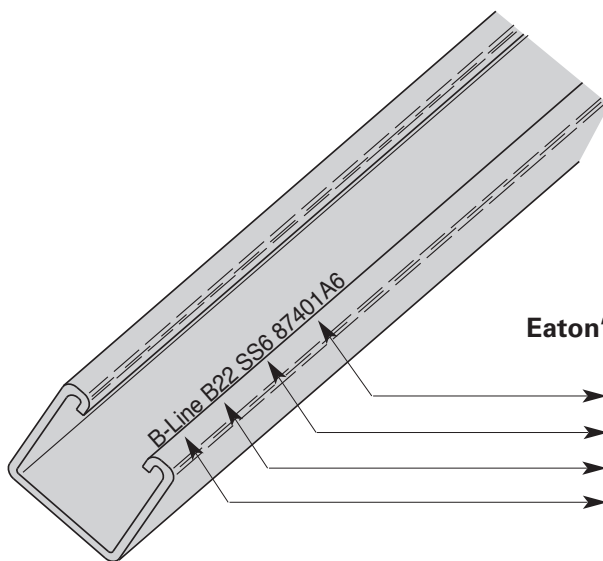

Eaton's B-Line Series Steel Strut is stamped with:

- Traceable to the steel's origin
- Material/Finish
- Part number designation
- Company Name

Finishes

Zinc Coatings

Zinc protects steel in two ways. First it protects the steel as a coating, and second acts as a sacrificial anode to repair bare areas such as cut edges, scratches, and gouges. The corrosion protection of zinc is directly related to its thickness and the environment. This means a .2 mil coating will last twice as long as a .1 mil coating in the same environment.

Galvanizing also protects cut and drilled edges.

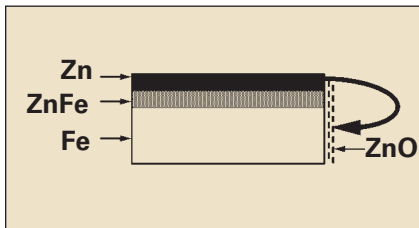

Electrogalvanized Zinc

Electrogalvanized Zinc (also known as zinc plated or electroplated) is the process by which a coating of zinc is deposited on the steel by electrolysis from a bath of zinc salts.

A rating of SC3, our standard, provides a minimum zinc coating thickness of .5 mils (excluding hardware, which is SC1 = .2 mils).

When exposed to air and moisture, zinc forms a tough, adherent, protective film consisting of a mixture of zinc oxides, hydroxides, and carbonates. This film is a barrier coating which helps slow subsequent corrosive attack on the zinc. This coating is usually recommended for indoor use in relatively dry areas, as it provides ninety-six hours protection in salt spray testing per ASTM B117.

Chromium / Zinc

Chromium / Zinc is a corrosion resistant composition, which was developed to protect fasteners and small bulk items for automotive use. The coating applications have since been extended to larger parts and other markets.

Chromium/Zinc composition is an aqueous coating dispersion containing chromium, proprietary organics, and zinc flake.

This finish provides 720 hours protection in salt spray testing per ASTM B117.

Pre-Galvanized Zinc

(Mill galvanized, hot dip mill galvanized or continuous hot dip galvanized) Pre-galvanized steel is produced by coating coils of sheet steel with zinc by continuously rolling the material through molten zinc at the mills. This is also known as mill galvanized or hot dip mill galvanized. These coils are then slit to size and fabricated by roll forming, shearing, punching, or forming to produce our pre-galvanized strut products.

The G90 specification calls for a coating of .90 ounces of zinc per square foot of steel. This results in a coating of .45 ounces per square foot on each side of the sheet. This is important when comparing this finish to hot dip galvanized after fabrication.

During fabrication, cut edges and welded areas are not normally zinc coated; however, the zinc near the uncoated metal becomes a sacrificial anode to protect the bare areas after a short period of time.

Hot Dip Galvanized After Fabrication (Hot dip galvanized or batch hot dip galvanized)

Hot dip galvanized strut products are fabricated from steel and then completely immersed in a bath of molten zinc. A metallic bond occurs resulting in a zinc coating that completely coats all surfaces, including edges and welds.

Another advantage of this method is coating thickness. Strut products that are hot dip galvanized after fabrication have a minimum thickness of 1.50 ounces per square foot on each side, or a total 3.0 ounces per square foot of steel, according to ASTM A123.

The zinc thickness is controlled by the amount of time each part is immersed in the molten zinc bath as well as the speed at which it is removed. The term "double dipping" refers to parts too large to fit into the galvanizing kettle and must be dipped one end at a time. It does not refer to extra coating thickness.

The layer of zinc which bonds to steel provides a dual protection against corrosion. It protects first as an overall barrier coating. If this coating happens to be scratched or gouged, zinc's secondary defense is called upon to protect the steel by galvanic action.

Hot-Dip Galvanized After Fabrication is recommended for prolonged outdoor exposure and will usually protect steel for 20 years or more in most atmospheric environments and in many industrial environments. For best results, a zinc rich paint (available from Eaton's B-Line Division) should be applied to field cuts. The zinc rich paint will provide immediate protection for these areas and eliminate the short time period for galvanic action to "heal" the damaged coating.

Anticipated Life of Zinc Coatings In Various Atmospheric Environments

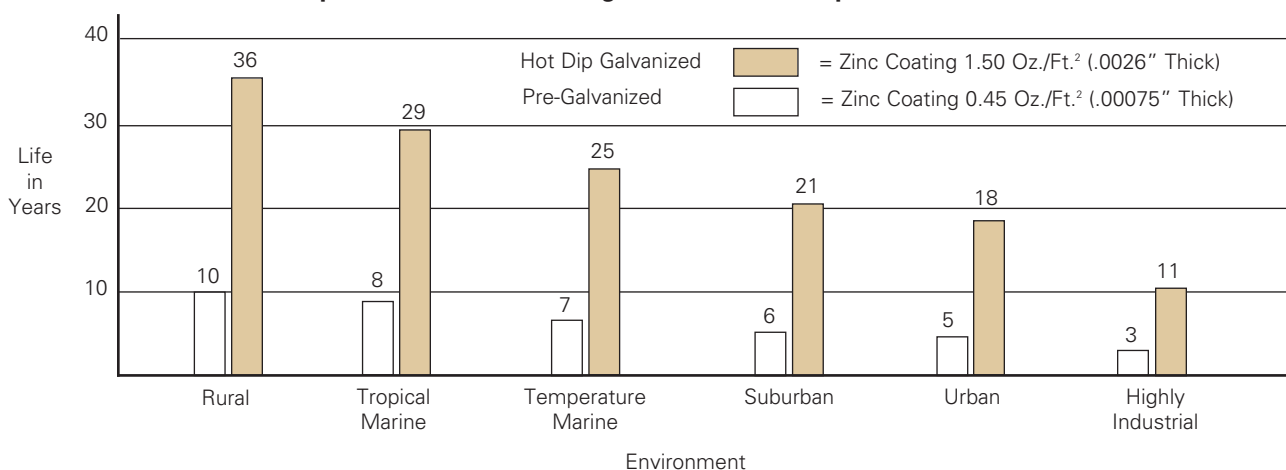

Technical Data

DURA GREEN™ and DURA-COPPER™ Epoxy Coatings

DURA GREEN and DURA-COPPER epoxy coatings are water borne epoxy coatings applied to B-Line series products by a precisely controlled cathodic electro-deposition process. This process is accomplished using a conveyor to transport channel and fittings through several cleaning, phosphating and application stages prior to being baked (See diagram below).

This custom-designed paint system is used for painting all channels, channel combinations, slotted angle, and fittings.

Samples are selected on a routine basis for salt spray (fog) testing to verify the quality of the finish. These tests are performed in accordance with ASTM B117 and evaluated and related according to ASTM D1654 (Tables 1 & 2).

The DURA GREEN and DURA-COPPER epoxy coatings have been tested and listed by Underwriters Laboratories in

accordance with "Standard for Surface Metal Raceway and Fittings, UL5" and "Standard for Pipe Hanger Equipment for Fire Protection Service, UL203".

Due to DURA GREEN's organically based composition, it seats itself into porous surfaces more completely and efficiently than zinc coatings. As these porous caverns are filled along the material profile, the outer finished surface demonstrates an increased smooth uniform plane which produces considerably less off-gassing when tested.

DURA GREEN channel meets or exceeds 100 level clean room standards. This was confirmed by testing the channel in accordance with Boeing (PCL) Standards, which are more stringent and complete than ASTM E595-93. DURA GREEN was found to be a superior finish, due in part to its proven application process.

Technical Data

Salt Spray Test Results

Type of Finish	Unscribed 5% Failure (1)	Scribed 1/8" (3.2) Creepage from Scribe (1)
DURA GREEN Epoxy	1000 Hours	312 Hours
Mill Galv. (Pre-Galv.) G90	192 Hours	288 Hours
Perma-Green	438 Hours	231 Hours
Zinc Chromate	36 Hours	96 Hours
Industry Green (Range)	10 to 36 Hours	4 to 30 Hours

(1) All salt spray (fog) tests conducted in accordance with ASTM B117 and evaluated and rated according to ASTM D1654 Tables 1 & 2. Tests are performed and certified by an independent testing laboratory.

DURA GREEN / DURA-COPPER Epoxy Coating Process

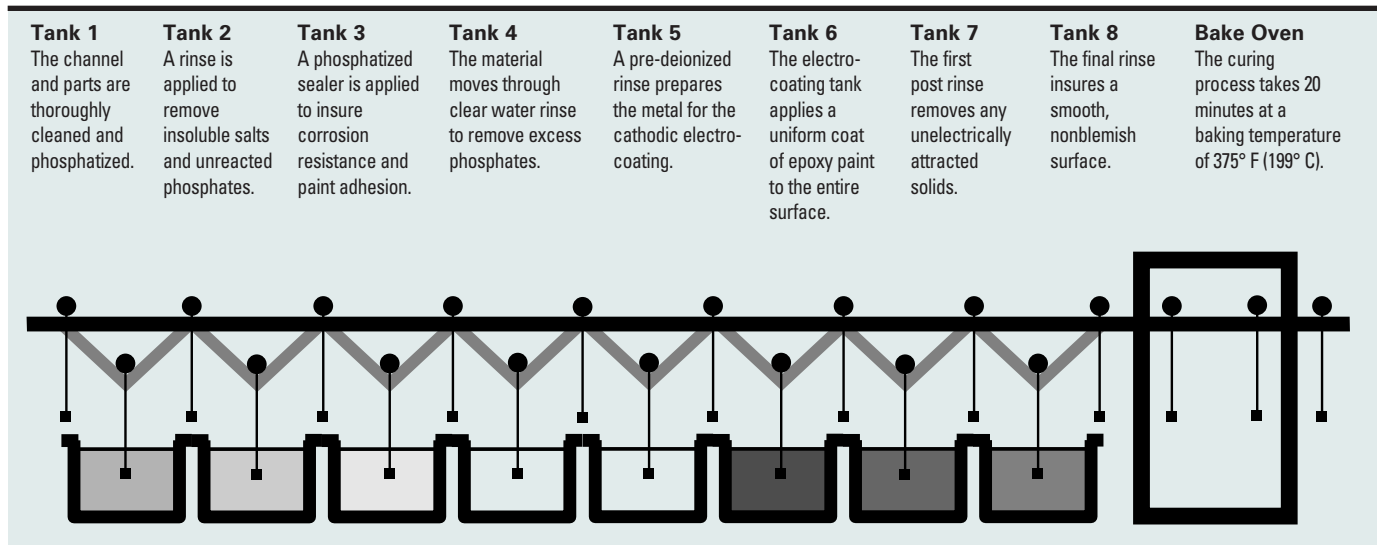

Welding

The welding procedures used in the fabrication of our steel products are in accordance with American Welding Society (AWS) Standards. To help achieve the highest quality in our manufacturing processes, our welders follow standards set by AWS Code.

Spot Welding

Spot welded back-to-back channel is manufactured using a modern DC powered resistance welder controlled by a microprocessor. This produces a series of spot welds with speed and consistency. Consistency is one of the most important advantages in specifying back-to-back channel. Variables such as weld

sequence, speed and duration are carefully controlled and monitored by a sophisticated electronic control system. A statistical quality control program, combining destructive and non-destructive testing, is used to help ensure high quality welds.

MIG Welding

MIG welded, more properly called gas metal arc welded (GMAW) combination channels and fittings, are produced when physical dimensions or certain combinations require a weld process other than automatic spot welding. The same quality control requirements are imposed on MIG welded and spot-welded products.

Quality Assurance

Our Quality Assurance Program has been developed and implemented for compliance with ISO9001:2008. We also comply with various industry standards and specifications. We have extensive experience in supplying metal framing components for the nuclear power generating industry, and upon request can provide products in compliance with 10CFR50 Appendix B, NQA-1 and 10CFR21. For more information on our quality capability please visit www.cooperblinc.com/nuclear.

Technical Data

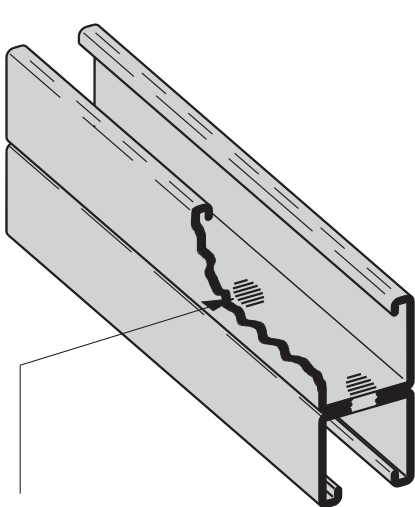

Spot Weld

1/2" (12.7mm) spot welds every 4" (101.6mm) on center

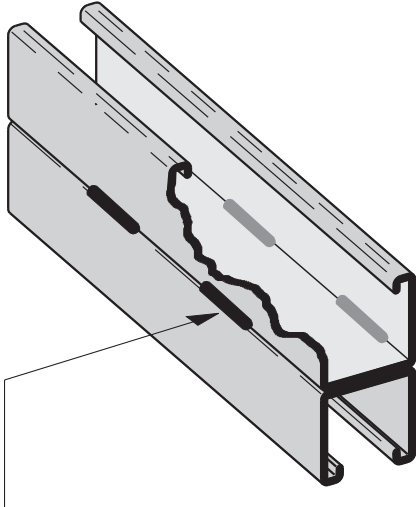

MIG Weld

3/4" (9.0mm) long MIG welds every 6" (152.4mm) on center

Corrosion

All metal surfaces are affected by corrosion. Depending on the physical properties of the metal and the environment to which it is exposed, chemical or electromechanical corrosion may occur.

Atmospheric Corrosion

Atmospheric corrosion occurs when metal is exposed to airborne liquids, solids or gases. Some sources of atmospheric corrosion are moisture, salt, dirt and sulphuric acid. This form of corrosion is typically more severe outdoors, especially near marine environments.

Chemical Corrosion

Chemical corrosion takes place when metal comes in direct contact with a corrosive solution. Some factors which affect the severity of chemical corrosion include: chemical concentration level, duration of contact, frequency of washing, and operating temperature.

Storage Corrosion

Wet storage stain (white rust) is caused by the entrapment of moisture between surfaces of closely packed and poorly ventilated material for an extended period. Wet storage stain is usually superficial, having no affect on the properties of the metal.

Light staining normally disappears with weathering. Medium to heavy buildup should be removed in order to allow the formation of normal protective film. Proper handling and storage will help to assure stain-free material. If product arrives wet, it should be unpacked and dried before storage. Dry material should be stored in a well ventilated "low moisture" environment to avoid condensation formation. Outdoor storage is undesirable, and should be avoided whenever possible.

Galvanic Corrosion

Galvanic corrosion occurs when two or more dissimilar metals are in contact in the presence of an electrolyte (i.e.: moisture). An electrolytic cell is created and the metals form an anode or a cathode depending on their relative position on the Galvanic Series Table. The anodic material will be the one to corrode. Anodic or cathodic characteristics of two dissimilar metals will depend on the type of each material. For example: If zinc and steel are in contact, the zinc acts as the anode and will corrode; the steel acts as the

Galvanic Series in Sea Water

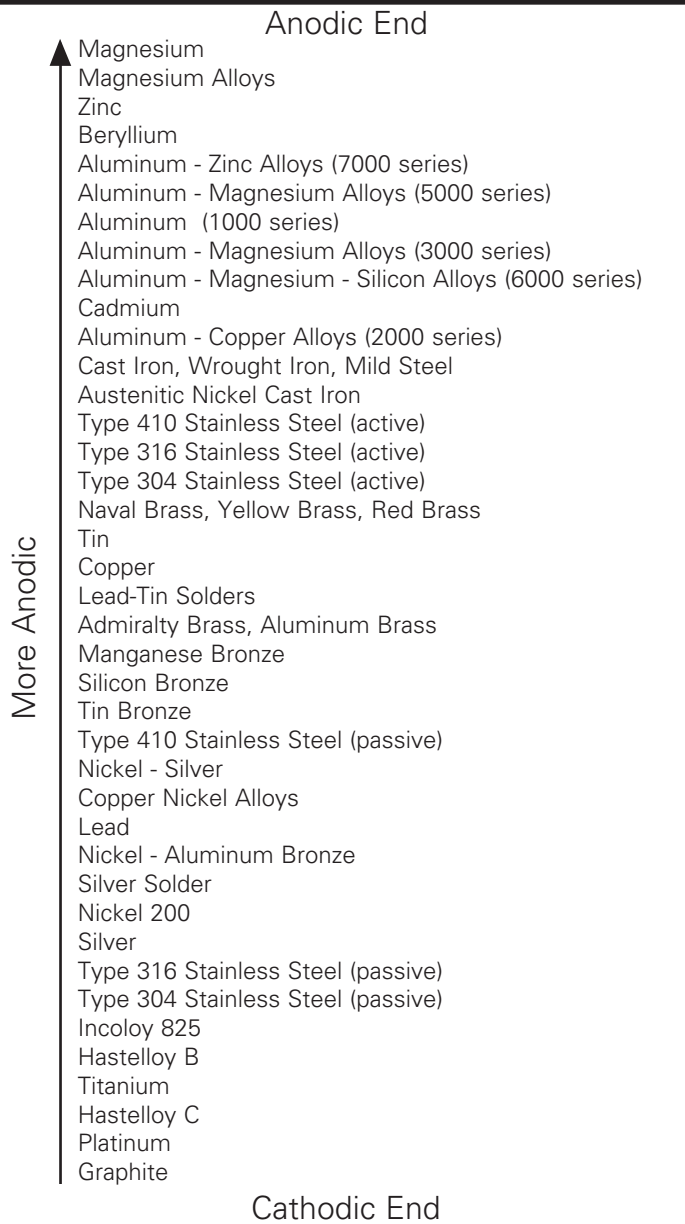

Metals in descending order of activity in the presence of an electrolyte.

cathode, and will be protected. If steel and copper are in contact, the steel is now the anode and will corrode.

The rate at which galvanic corrosion occurs depends on several factors:

1. The relative position on the Galvanic Series Table - the further apart materials are in the Galvanic Series Table, the greater the potential for corrosion of the anodic material.

2. The amount and concentration of electrolyte present - an indoor, dry environment will have little or no galvanic corrosion compared to a wet atmosphere.

3. The relative size of the materials - a small amount of anodic material in contact with a large cathodic material will result in greater corrosion. Likewise, a large anode in contact with a small cathode will decrease the rate of attack.

Chemical	Aluminum	DURA GREEN™	PVC	Type 304 Stainless	Type 316 Stainless	Zinc Coated Steel
Acetic Acid 10%	R	NR	R	R	R	NR
Acetic Acid 2%	R	F	R	R	R	NR
Acetone	R	R	NR	R	R	R
Ammonium Hydroxide-Conc.	R	R	R	R	R	-
Ammonium Hydroxide 10%	F	R	R	R	R	-
Ammonium Hydroxide 2%	R	R	R	R	R	-
Benzene	R	R	NR	R	R	-
Bromine Water	NR	R	R	NR	NR	-
Butanol (Butyl Alcohol)	R	R	R	R	R	R
Carbon Disulfide	R	R	NR	R	R	-
Carbon Tetrachloride	F	R	F	R	R	-
Chlorine Water	R	R	R	NR	F	R
Cutting Oil	-	R	-	-	-	-
Diethanolamine	R	R	NR	-	-	NR
Ethanol	R	R	R	R	R	R
Ethyl Acetate	R	R	NR	-	-	R
Ethylene Dichloride	F	R	NR	-	-	R
Formaldehyde 20%	R	R	R	R	R	R
Gasoline	R	R	R	R	R	R
Glycerine	R	R	R	R	R	R
Household Detergent 10%	F	R	R	R	R	-
Hydrochloric Acid 40%	NR	NR	R	NR	NR	NR
Hydrochloric Acid 10%	NR	F	-	NR	NR	NR
Hydrochloric Acid 2%	NR	F	-	NR	NR	NR
Hydrogen Peroxide 30%	R	NR	R	R	R	-
Hydrogen Peroxide 3%	R	R	-	R	R	-
Hydrogen Sulfide (Gas)	R	R	R	F	R	-
JP-4 Jet Fuel	R	R	R	R	R	-
Lactic Acid 85%	F	R	R	NR	-	-
Latex	R	R	-	R	R	NR
Linseed Oil Fatty Acid	R	F	R	R	R	-
Methanol	R	R	R	R	R	R
Methyl Ethyl Ketone	R	R	NR	-	-	R
Methyl Isobutyl Ketone	R	R	NR	-	-	R
Mineral Spirits	R	R	-	-	-	-
Motor Oil-10W	R	R	R	R	R	R
Naphtha, VM&P	R	R	R	R	R	R
Nitric Acid 2%	F	NR	R	R	R	-
Perchloroethylene	R	R	-	-	-	NR
Petroleum Ether	-	R	-	R	R	R
Phenol 10%	R	R	NR	R	R	R
Phosphoric Acid 2%	F	NR	R	R	R	NR
Potassium Hydroxide 50%	NR	R	R	R	R	-
Potassium Hydroxide 10%	NR	R	R	R	R	-
Potassium Hydroxide 2%	NR	R	R	R	R	-
Sodium Chloride 25%	F	R	R	R	R	F
Sodium Hydroxide 50%	NR	R	R	R	R	NR
Sodium Hydroxide 10%	NR	R	R	R	R	F
Sodium Hydroxide 2%	NR	R	R	-	-	-
Sodium Hypochlorite-C1. 10%	F	R	R	-	-	-
Sodium Hypochlorite-C1. 6%	F	R	R	NR	R	-
Sulfuric Acid 2%	F	NR	R	NR	R	NR
Tall Oil Fatty Acid (Syfate 94)	R	R	R	-	-	-
Tannic Acid 50%	F	R	R	R	R	-
Water-Deionized	R	R	R	R	R	F
Water-Sea	F	F	R	R	R	F
Water-Tap	R	R	R	F	F	R
Xyol	R	R	NR	-	-	-

For fiberglass corrosion chart see page 225.

The corrosion data given in this table is for general comparison only.

The presence of contaminants and the effect of temperature in chemical environments can greatly affect the corrosion of any material. We strongly suggest that field service tests or simulated laboratory tests using actual environmental conditions be conducted in order to determine the proper materials and finishes to be selected.

R=Recommended

F=May be used under some conditions

NR=Not Recommended

-Information not available

Design of B-Line series Strut Systems

Beams

Beams are usually defined as horizontal members which are subjected to vertical loads such as shelves, platforms or supports for pipes, conduits or cable trays.

The following is a brief overview of common beam configurations:

Simple Beam

An example of a simple beam is a length of channel placed across two cylinders. When a load is applied, the channel will support the load because of its stiffness. The cylinders serve to support the channel, but do not interfere with its natural tendency to flex or bend. Simple beam analysis is used almost universally for beam comparisons, even though it is seldom practical in field installations.

A cable tray or conduit trapeze hanger closely resembles a simple beam.

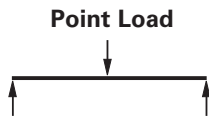

Fixed Beam

This type of fixed support restricts the movement of the ends of the channel when a load is applied. Because of this, the stiffness of the channel at the ends and center is employed to resist the load. The result is a load capability which is greater than that of an identical simple beam.

The fixed beam can be approximated by bolting or welding a length of channel to rigid supports.



Cantilever Beam

Cantilever beams are often viewed as variations of a fixed beam, but they have special characteristics of their own. One end of the channel is firmly attached to a rigid support while the other end remains completely free.

A shelf bracket is an example of a cantilever beam.



Continuous Beam

This beam configuration is commonly used in lighting installations. The continuous beam possesses traits of both the simple and fixed beams. When equal loads are applied to all spans simultaneously, the counter-balancing effect of the loads on both sides of a support restricts the movement of the channel at the support, similar to that of the fixed beam. The end spans behave substantially like simple beams.

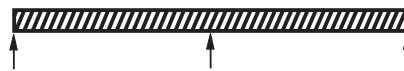

Continuous beam installations can typically support 20% more load than a simple beam of the same span with approximately half the deflection.

Therefore, simple beam data should be used for a general comparison only. An example of this configuration is found in a long run of channel when installed across several supports to form a number of spans.

Deflection

Deflection, commonly referred to as "sag", is inherent in applying a load to a beam and cannot be avoided. Any and all beams will deflect when loaded. The amount of deflection will vary depending upon the material and the stiffness or moment of inertia. The deflection equations in this section show that increasing the stiffness can be increased by a variety of methods. Increasing the depth of the channel is the most direct method.

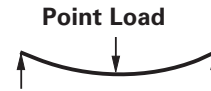

The material used affects deflection in a manner which is significantly different from the way in which it affects load capacity. The deflection under load is inversely proportional to a material property known as the "modulus of elasticity" designated by "E".

The modulus of elasticity is dependent upon the basic composition of the material and is not necessarily related to the material's strength.

Safety Factor

The design loads given for strut beam loads are based on a simple beam condition using allowable stress of 25,000 psi. This allowable stress results in a safety factor of 1.68. This is based upon a virgin steel minimum yield strength of 33,000 psi cold worked during rolling to an average yield stress of 42,000 psi.

Aluminum typically has an elastic modulus which is $\frac{1}{3}$ that of steel even though they may have identical strength. As a result, the deflection of aluminum channel will be three times that of steel channel under equal loading. In areas where structures will be subject to general viewing, deflection can produce a displeasing effect. To the untrained eye, a sagging channel may appear to be a result of poor design or excessive loading. This is not usually the case. Many properly designed channel installations will show a noticeable deflection at their designed loads. In areas where cosmetics are not important, deflection should not be a factor.

Designing an entire installation based on minimal deflection could result in an over designed structure. This translates into increased material and installation cost. Where cosmetics are important, it may be necessary to limit the deflection to an aesthetically pleasing amount. This "acceptable deflection" amount is typically given as a fraction of the span.

1/240 span deflection is typically the limit where the amount of deflection appears negligible. For example, a beam span of 240" would be allowed 1" (240/240) of deflection at the mid point. A 120" span would only be allowed $\frac{1}{2}$ " (120/240) of deflection. The maximum load for the channel must be limited in order to remain under these deflection requirements. The allowable load resulting in 1/240 span deflection is posted in the beam load chart for each channel size.

For even more stringent deflection requirements, an allowable load is listed in the beam load charts which results in **1/360 span** deflection. This amount of deflection is sometimes used for beams in finished ceilings that are to be plastered.

Twisting & Lateral Bracing

Loading of strut on long spans can cause torsional stress, resulting in the tendency of the strut to twist or bend laterally. This phenomenon reduces the allowable beam loads as shown in the beam loading charts. It is recommended that long spans be supported in a manner to prevent twisting (fixed ends), and that the channel have adequate lateral bracing. Many typical strut applications provide this support and bracing inherently. Piping,

tubing, cable trays, or conduits mounted to the strut with straps and clamps prevent twisting or lateral movement. If no such lateral support exists, contact the factory for loading recommendations.

Columns

Columns are vertical members which carry loads in compression. One common example of a channel column is the vertical members of a storage rack.

In theory, a column will carry a load equal to its cross sectional area multiplied by the ultimate compressive stress of the material of which the column is made. In reality, there are many factors affecting the load capacity of a column, such as the tendency to buckle or twist laterally (torsional-flexural buckling), the type of connection at the top or bottom, the eccentricity of the load application, and material imperfections. Several of these failure modes have been considered in the allowable column load tables shown in the "Channel" section of this catalog.

We strongly recommends that the engineer perform a detailed study of the many variable conditions before the selection process begins.

Design Factors to be Considered

The loading capacity of channel depends primarily on the material, its cross-sectional design, and the beam or column loading configuration. It should be noted that if two lengths of channel have identical designs and configurations, the one made of the stronger base material will support a larger load. Therefore, any comparison of channel should begin by determining whether the materials are approximately equal in strength.

The column loading chart for each channel lists the allowable load for each channel in compression. This load varies depending on the support condition or "K-factor".

Several "K-factors" are listed, which correspond to the following support conditions:

- K = .8 pinned top - fixed bottom
- K = .65 fixed top - fixed bottom
- K = 1.0 pinned top - pinned bottom
- K = 1.2 free top - fixed bottom

There are a number of physical properties which are important to the complete design of a channel member; the "section modulus" designated as "Sx" or "Sy", "moment of inertia" designated by "Ix" or "Iy", and the "radius of gyration" which is given as "rx" or "ry".

Every structural material has its own maximum or ultimate stress, which is usually expressed in "pounds per square inch" (pascals). Any load which causes a member to fail is referred to as its "ultimate" load. In order to prevent channel from being accidentally loaded up to or beyond its ultimate load, a safety factor is included into the design. The ultimate load is divided by the safety factor to obtain the "recommended" or "allowable" working load.

When evaluating channel under various beam conditions, it is often more convenient to compare in terms of the ultimate or recommended "bending moment". Simple equations show the stress is directly proportional to the bending moment.

Therefore, comparing bending moments can save time in repeated calculations. The chart containing Formulas on Common Beam Loadings (following page) shows how to calculate the bending moment for various configurations and load conditions. It should be noted that the bending moment is usually not constant, but varies along the length of the span. However, the channel must be designed for a single point, which is the point of maximum bending moment.

For information regarding dynamic or seismic design, contact us.

General Information

Torque

The torque values given throughout the catalog are to be used as a guide only.

The relationship between the applied torque or torque wrench reading and the actual tension created in the bolt may be substantially different. For example, a dry non-lubricated bolt with a heavy plating may rate 50% as efficient as a bolt which is lubricated with a mixture of heavy oil and graphite. Other important factors affecting torque-tension relationships include friction under the bolt head or nut, hole tolerances, and torque wrench tolerances. Accuracy of many commercial torque wrenches may vary as much as plus or minus 25%.







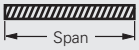

Charts and Tables

Charts and tables in this section are compiled from information published by nationally recognized organizations and are intended for use as a guide only. We recommend that users of this information determine the validity of such information as applied to their own application.

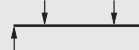
Technical Data

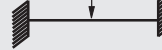
The data shown in the beam load charts for appropriate channels on pages 50 thru 71 is for simply supported, single span beams with a uniformly distributed load. For other loading and/or support conditions, use the appropriate factor from the chart below.

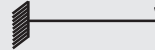
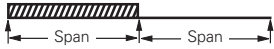
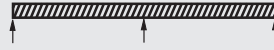
Technical Data

Load and Support Condition	Load Factor	Deflection Factor
Simple Beam - Uniform Load 	1.00	1.00
Simple Beam - Concentrated Load at Center 	.50	.80
Simple Beam - Two Equal Concentrated Loads at 1/4 Points 	1.00	1.10
Beam Fixed at Both Ends - Uniform Load 	1.50	.30
Beam Fixed at Both Ends - Concentrated Load at Center 	1.00	.40
Cantilever Beam - Uniform Load 	.25	2.40
Cantilever Beam - Concentrated Load at End 	.12	3.20
Continuous Beam - Two Equal Spans - Uniform Load on One Span 	1.30	.92
Continuous Beam - Two Equal Spans - Concentrated Load on Both Spans 	1.00	.42
Continuous Beam - Two Equal Spans - Concentrated Load at Center of One Span 	.62	.71
Continuous Beam - Two Equal Spans - Concentrated Load at Center of Both Spans 	.67	.48

Examples:

Problem:

Calculate the maximum allowable load and corresponding deflection of a simply supported B22 beam with a concentrated load at midspan as shown.

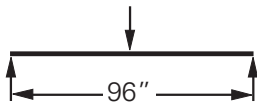

Solution :

From beam load chart for B22 (page 56), maximum allowable Load is A and the corresponding deflection is B.
Multiplying by the appropriate factors shown in the chart above.

LOAD = A x load factor = _____
DEFLECTION = B x deflection factor = _____

Problem:

Calculate the maximum allowable load and corresponding deflection of a cantilever B52 beam with a uniformly distributed load.



Solution:

From beam load chart for B52 (page 67), maximum allowable load is A and the corresponding deflection is B.
Multiplying by the appropriate factors shown in chart above.

LOAD = A x load factor = _____
DEFLECTION = B x deflection factor = _____

Recommended Bolted Metal Framing (Strut System) Specification

Brackets [] indicate alternative specifications which may be substituted by the project engineer.

Part 1 - General

1.01 Work Included

- A.** Continuous slot, bolted framing channels and all associated fittings and hardware.
- B.** Trapeze type supports for cable tray, conduit, pipe and other similar systems.
- C.** Use of bolted metal framing as a surface metal raceway.

1.02 References

- A.** ASTM A108 - Specification for Steel Bars, Carbon, Cold Finished, Structural Quality.
- B.** ASTM A123 - Specification for Zinc (hot-dip galvanized) Coatings on Products Fabricated from Rolled, Pressed, and Forged Steel Shapes, Plates, Bars and Strips.
- C.** ASTM A1011, 33,000 PSI min. yield - Specification for Steel, Sheet and Strip, Carbon, Hot-Rolled, Structural Quality.
- D.** ASTM B633 - Specification for Electrodeposited Coatings of Zinc on Iron and Steel.
- E.** ASTM A653 33,000 PSI min. yield G90 - Specification for Steel Sheet, Zinc Coated (Galvanized) by the Hot-Dip Process, Structural Quality.
- F.** ASTM A1018 - Standard Specification for Steel, Sheet and Strip, Heavy-Thickness Coils, Carbon, Hot-Rolled, Structural Quality.
- G.** MFMA - Metal Framing Standards Publication, MFMA-4.

1.03 Quality Assurance

- A.** Manufacturers: Firms regularly engaged in the manufacture of bolted metal framing of the types required, whose products have been in satisfactory use in similar service for not less than 5 years.
- B.** A material heat code number shall be stamped on all strut and fittings. This is required to maintain traceability of the product to the material test reports to the ASTM standard.
- C.** For stainless steel items, the part number shall contain a material designator (EXAMPLE: B-Line B22SS6 for type 316 or B22SS4 for type 304), or a separate stamp shall be included to reference the type of material used.
- D.** MFMA Compliance: comply with the latest revision of MFMA Standard Publication Number MFMA-4, "Metal Framing".

E. NEC Compliance: Comply with the latest revision NFPA 70 - Article 352 "Surface Metal Raceways and Surface Nonmetallic Raceways".

F. UL Compliance: Comply with UL "Standard for Surface Metal Raceway and Fittings".

1.04 Submittals

- A.** Submit drawings of strut and accessories including clamps, brackets, hanger rods and fittings.
- B.** Submit manufacturer's product data on strut channels including, but not limited to, types, materials, finishes, gauge thickness and hole patterns. For each different strut cross section, submit cross sectional properties including Section Modulus (S_x) and Moment of Inertia (I_x).

1.05 Delivery, Storage and Handling

- A.** Deliver strut systems and components carefully to avoid breakage, denting, and scoring finishes. Do not install damaged equipment.
- B.** Store strut systems and components in original cartons and in clean dry space; protect from weather and construction traffic.

Part 2 - Products

2.01 Acceptable Manufacturers

A. Manufacturer: Subject to compliance with these specifications, strut systems to be installed shall be as manufactured by Eaton's B-Line Business [or engineer approved equal.]

2.02 Strut Channels and Components

- A.** General: Strut shall be 1⁵/₈" wide in varying heights and welded combinations as required to meet load capacities and designs indicated on the drawings.
- B.** Material and Finish: Material and finish specifications for each strut type are as follows:

1. Aluminum: Strut shall be manufactured of extruded aluminum alloy 6063-T6. All fittings and hardware shall be zinc plated according to ASTM B633. For outdoor use, all fittings and hardware shall be stainless steel Type 316 [Type 304] or chromium zinc, ASTM F1136 Gr. 3.

2. Epoxy Painted: Strut shall be made from steel meeting the minimum mechanical properties of ASTM A1011 33,000 PSI min yield, then painted with water borne epoxy applied by a cathodic electro-deposition

process. Fittings shall be manufactured from steel meeting the minimum requirements of ASTM A1018 33,000 PSI min. yield. The fittings shall have the same epoxy finish as the strut. Threaded hardware shall be zinc plated in accordance with ASTM B633 Service Class 1 (SC1). Service Class 1 is not an acceptable coating for fittings or components other than threaded hardware.

3. Pre-Galvanized Steel: Strut shall be made from structural quality steel meeting the minimum mechanical properties of ASTM A653 33,000 PSI min. yield, mill galvanized coating designation G90. Fittings shall be manufactured from steel meeting the minimum requirements of ASTM A1018 33,000 PSI min. yield and zinc plated in accordance with ASTM B633 service class 3 (SC3). Threaded hardware shall be zinc plated in accordance with ASTM B633 Service Class 1 (SC1). Service Class 1 is not an acceptable coating for fittings or components other than threaded hardware.

4. Hot-Dip Galvanized Steel: Strut shall be made from structural quality steel meeting the minimum mechanical properties of ASTM A1011 33,000 PSI min. yield and shall be hot-dip galvanized after fabrication in accordance with ASTM A123. Fittings shall be manufactured from steel meeting the minimum requirements of ASTM A1018 33,000 PSI min. yield, and hot-dip galvanized after fabrication in accordance with ASTM A123. All hardware shall be stainless steel Type 316 [Type 304] or chromium zinc ASTM F1136 Gr. 3. All hot-dip galvanized after fabrication products must be returned to point of manufacture after coating for inspection and removal of all sharp burrs.

5. Stainless Steel: All strut, fittings and hardware shall be made of AISI Type 316 [Type 304] stainless steel as indicated. Channels must be identified as required in previous section 1.03 Quality Assurance.

Part 3 - Execution

3.01 Installation

A. Install strut as indicated; in accordance with equipment manufacturer's recommendations, and with recognized industry practices.

B. All nuts and bolts shall be tightened to the following values.

Bolt Size	Torque (ft-lbs)
1/4-20	6
5/16-18	11
3/8-16	19
1/2-13	50

4Dimension Strut Information

Changing how we build our future

Eaton's 4Dimension™ strut system changes how installers will build and install support systems for electrical, mechanical, plumbing, HVAC and data centers in new and retrofit commercial and industrial applications.

The revolutionary strut profile design and innovative accessories help installers compress project schedules and cut material costs without sacrificing load while increasing configuration flexibility.

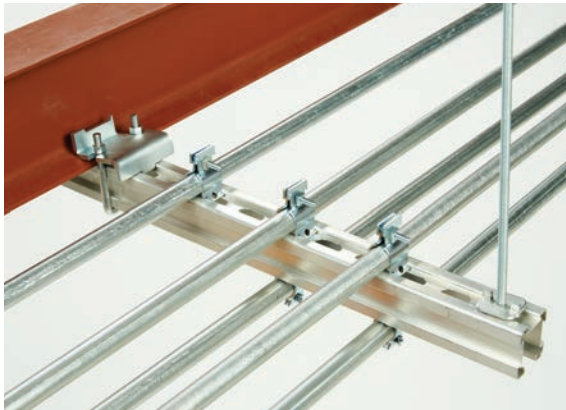

4Dimension Strut

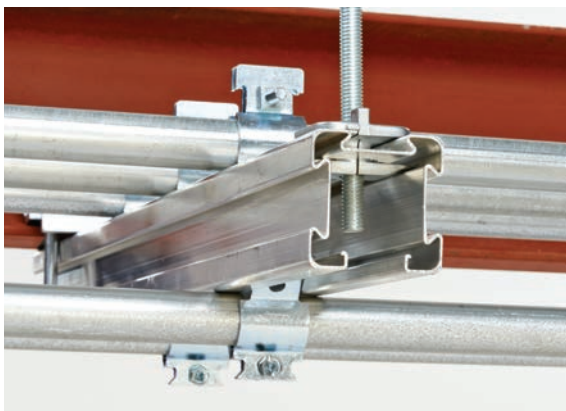
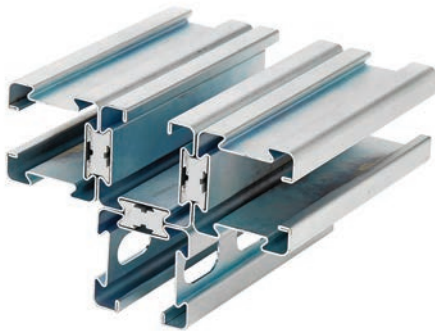

Innovative features

- Profiles with two-sided and four-sided functionality
- Superior strength, lighter weight for improved performance
- Modular design provides versatility
- SH hole accepts $\frac{5}{8}$ " hardware
- Innovative fitting solutions with virtually hundreds of possibilities
- Ideal for new and retrofit applications
- Meets or exceeds MFMA standards
- Patents - listed on product pages

Lowest total cost solution

- Up to 50% reduction in installation time for trapeze applications
- Up to 50% reduction in material cost in many applications
- Helps save space and weight by fully utilizing multiple sides for ease and flexibility of installation
- Functional replacement for back to back strut system, with considerable cost, time, and material savings
- Multi-side design reduces complexity of higher cost fittings required for many applications
- Compatible with most traditional fittings and accessories (shown throughout catalog with the following symbol 

For more information, visit
www.cooperline.com/4Dimension.

CoSPEC™ specifier center is designed to help you easily SELECT, VIEW and DOWNLOAD Eaton's B-Line Series product design content in any one of nearly one hundred non-proprietary and proprietary CAD, BIM, PDMS, and graphics formats, which helps speed the integration of the content into your design project.

Features

- Easy integration and configuration
- Comprehensive library of 2D drawings and 3D models for CAD, BIM, PDMS, SP3D, and graphics output
- Up-to-date software versions and product data information
- Submittals and specification sheets in PDF format
- Proprietary file format outputs are native to the chosen software

Nearly a Hundred Download Options

- Aveva PDMS and Intergraph SmartPlant SP3D (on select products) content
- Autodesk Revit output available
- Proprietary formats from AutoCAD to SolidWorks to Catia
- Non-proprietary formats like DXF and STEP, and more
- Graphics files in a number of formats including EPS

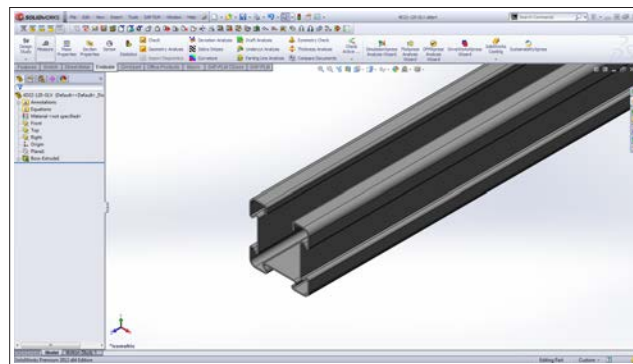

4Dimension Strut

To get started planning your next project, visit us at Eaton.com/CoSPEC.

Select

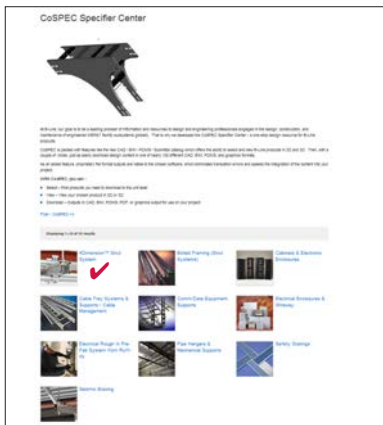

View

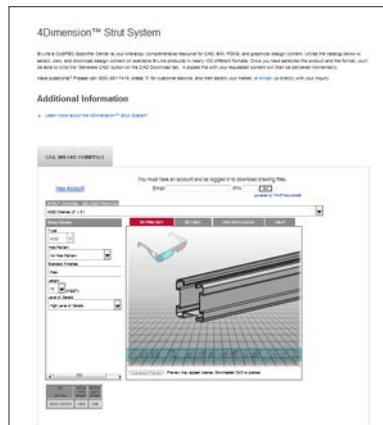

Download



4Dimension Applications

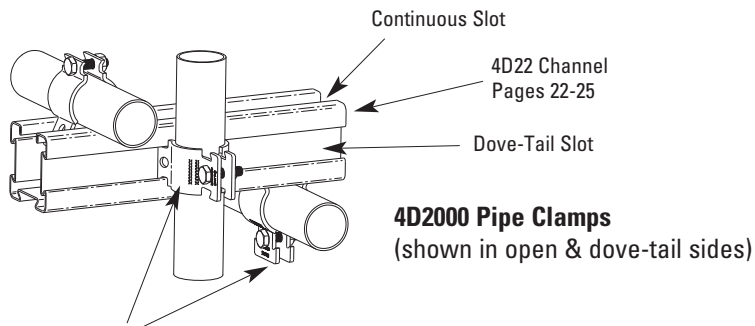
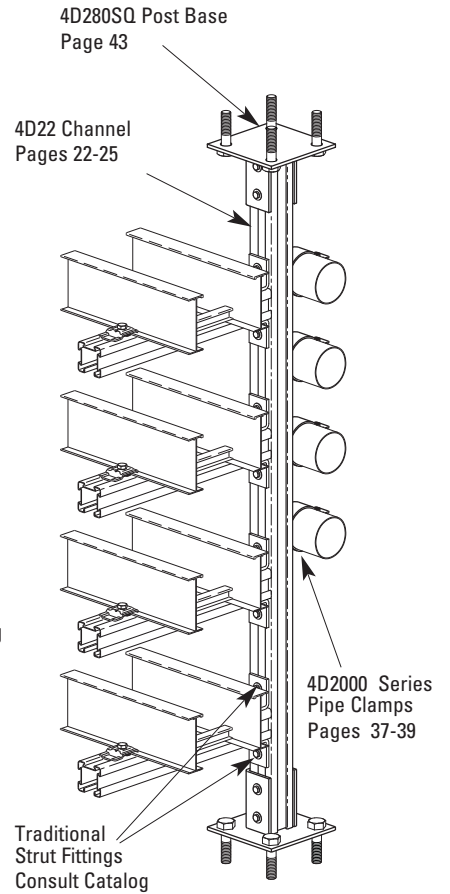
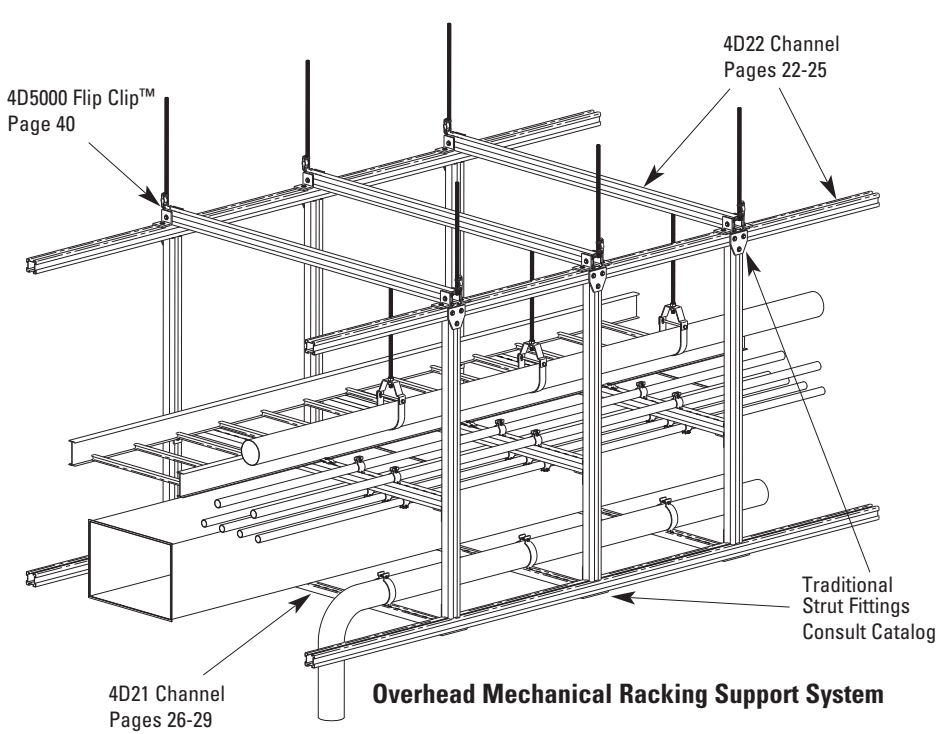

4D2000 Series Pipe Clamps
Pages 37-39

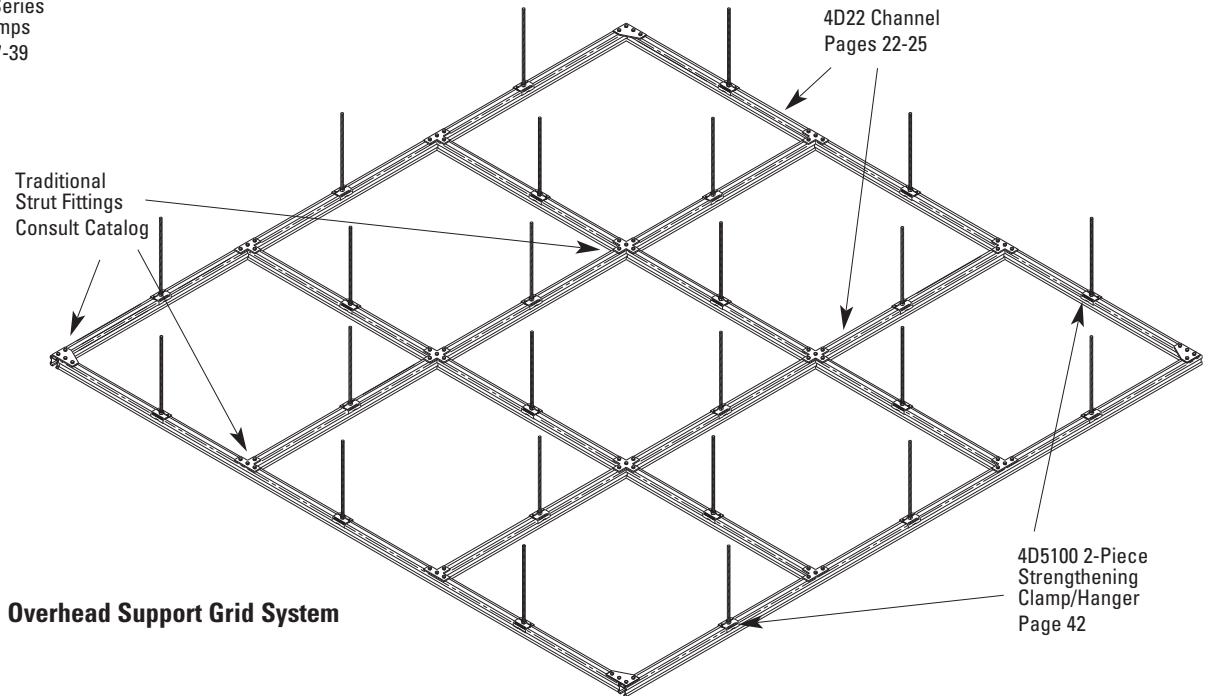

Dimensions are in inches unless otherwise noted. Metric dimensions are in parentheses and are in millimeters unless otherwise noted.

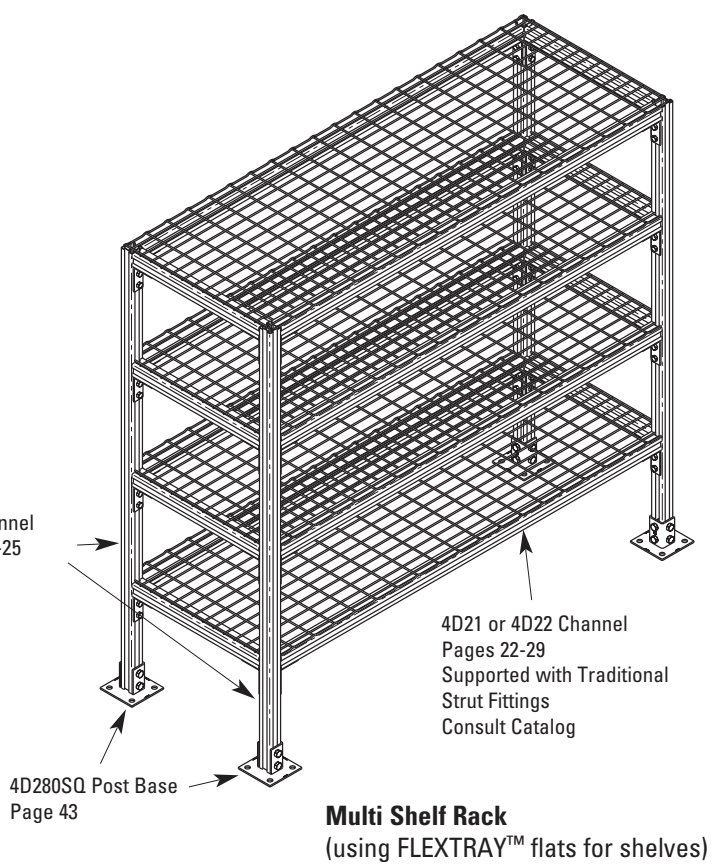
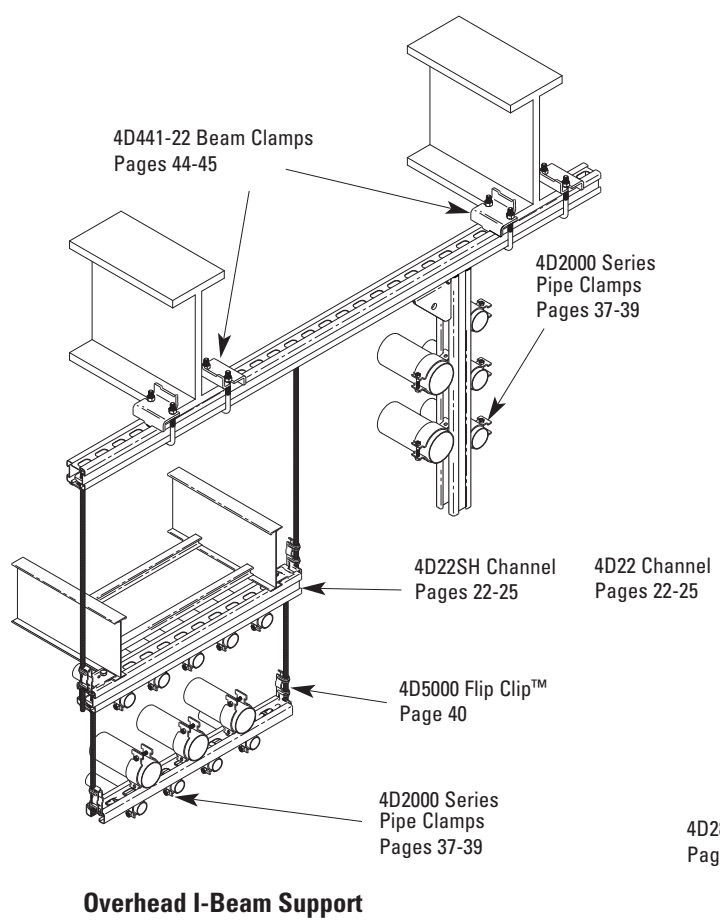
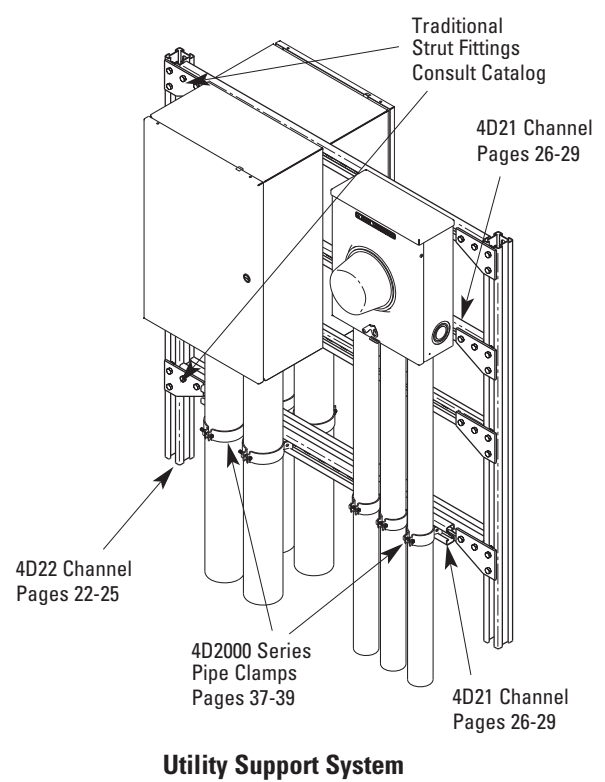
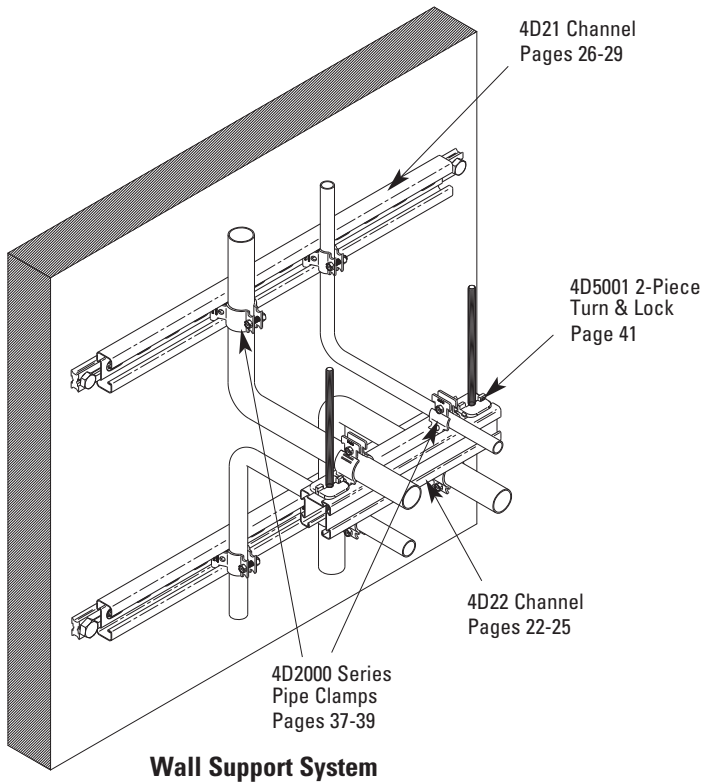

Dimensions are in inches unless otherwise noted. Metric dimensions are in parentheses and are in millimeters unless otherwise noted.

4Dimension Channels

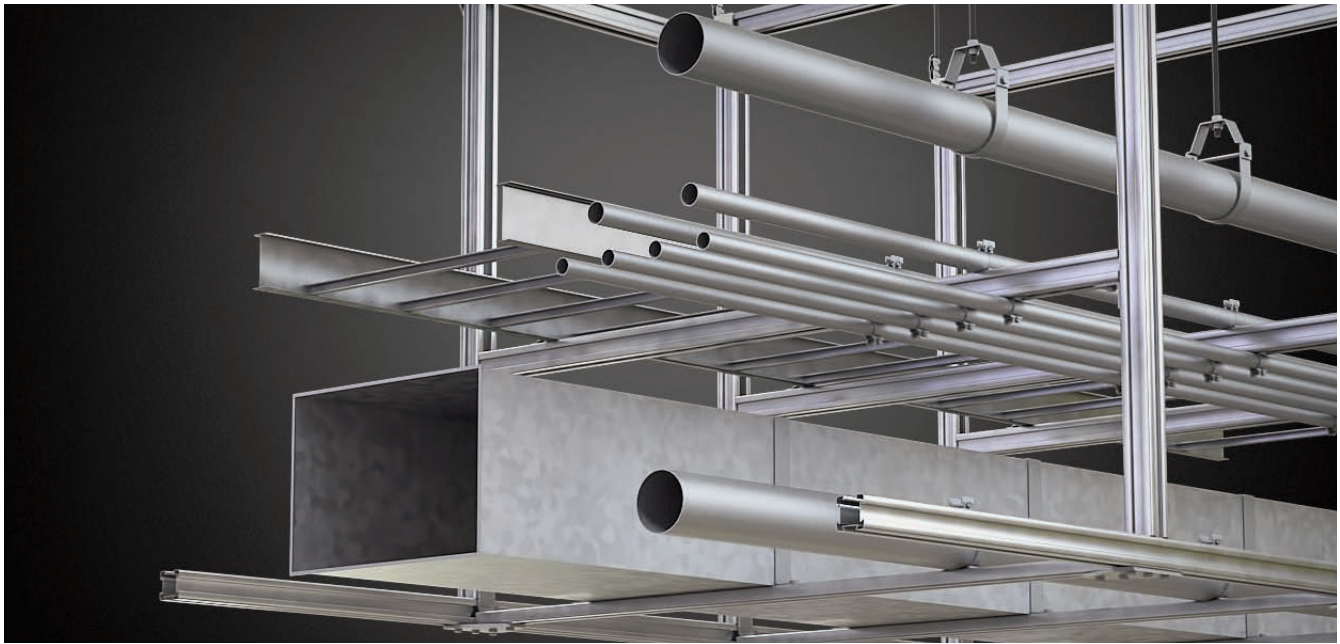

4Dimension Strut

Channel

4Dimension™ channel is cold formed on our modern rolling mills from 18 Ga. (1.2mm) low carbon steel. A continuous slot with returned lips and up to three dovetail designed sides provide the ability to make attachments on multiple sides of channel.

Lengths & Tolerances

All channels excluding SH style: $\pm 1/8"$ (3.2mm) on 10' (3.05m) and $\pm 3/16"$ (4.76mm) on 20' (6.09m)

All 'SH' channels only: $\pm 1/4"$ (6.35mm) on 10' (3.05m) and $\pm 1/2"$ (12.70mm) on 20' (6.09m)

Custom lengths are available upon request.

Slots

Slotted series of channels offer full flexibility. A variety of pre-punched slot patterns eliminate the need for precise field measuring for hole locations. Slots offer wide adjustments in the alignment and bolt sizing.

Dove-Tail Sides

A variety of pre-punched $9/16"$ (14.3 mm) diameter hole patterns are available in our channels. These hole patterns provide an economical alternative to costly field drilling required for many applications.

Materials & Finishes (Unless otherwise noted)

Steel: Plain & Pre-galvanized

18 Ga. (1.2mm)

Note: A minimum order may apply on special material and finishes.

Design Load (Steel & Stainless Steel)

The design loads given for strut beam loads are based on a simple beam condition. This allowable stress results in a safety factor of 1.68.

Metric

Metric dimensions are shown in parentheses. Unless noted, all metric dimensions are in millimeters.

Compatibility of B-Line series strut products with 4Dimension Strut System

Throughout the catalog, strut products that are compatible with the 4Dimension strut system will be flagged with the following symbol.



Recommended Torque (as shown in tables)

Note: Refer to bottom of page 4D08 for special torquing note of 4D21SH and 4D22SH or 4D21S and 4D22S trapeze assemblies.

Finish Code	Finish	Specification
PLN	Plain	ASTM A1011, 50,000 PSI min. yield
GRN	DURA GREEN™	
GLV	Pre-Galvanized	ASTM A653 50,000 PSI min. yield
HDG	Hot-Dipped Galvanized	ASTM A123
YZN	Yellow Zinc Chromate	ASTM B633 SC3 Type II
SS4	Stainless Steel Type 304	ASTM A240
SS6	Stainless Steel Type 316	ASTM A240

Bolt Size	1/4"-20	5/16"-18	3/8"-16	1/2"-13
ft-lbs	6	11	19	50
Nm	8	15	26	68

Bolt Size	M6x1	M8 x1.25	M10 x 1.5	M12x1.75
Nm	12	17	36	62
ft-lbs	9	13	27	46

Dimensions are in inches unless otherwise noted. Metric dimensions are in parentheses and are in millimeters unless otherwise noted.

Selection Chart for Channels, Materials and Hole Patterns

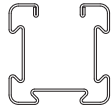
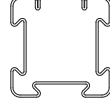
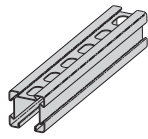
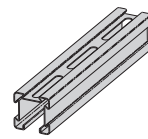
Channel Type	Channel Dimensions		Material & Thickness *			Channel Hole Pattern	
	Height	Width	Steel	Stainless Steel		SH <small>⁵/₈" x ¹/₄" slots on 2" centers</small>	S <small>¹³/₃₂" x 3" slots</small>
				Type 304	Type 316		
			1	3	4		
4D21	1 ¹ / ₁₆ " (27.0)	2 ¹ / ₈ " (54.0)	18 Ga.	18 Ga.	18 Ga.	<u>1</u> <u>2</u> <u>3</u>	<u>1</u> <u>2</u> <u>3</u>
4D22	2 ¹ / ₈ " (54.0)	2 ¹ / ₈ " (54.0)	18 Ga.	18 Ga.	18 Ga.	<u>1</u> <u>2</u> <u>3</u>	<u>1</u> <u>2</u> <u>3</u>

The selection has been prepared to provide a reference for available channel, materials and hole patterns. Material types available for various hole patterns are defined by numbers 1 thru 3. Some stainless steel channels with hole patterns are available on special order only.

*Metric equivalent for thicknesses:
18 Ga. = 1.2 mm

Properties may vary due to commercial tolerances of the material.

- 1 Steel
- 2 Type 304 Stainless Steel
- 3 Type 316 Stainless Steel

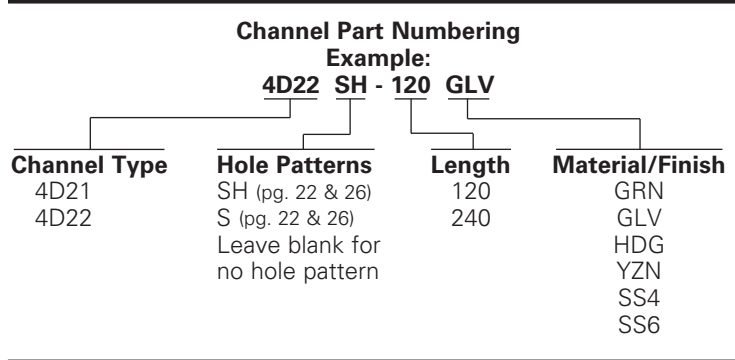

4Dimension Strut

Recommended Torque (4D21SH & 4D22SH or 4D21S & 4D22S trapeze assemblies)

Recommended torque on 4Dimension trapeze hangers using 4D21SH and 4D22SH or 4D21S and 4D22S channel and traditional hardware (B200 series square washer, hex nuts, and lock washers) is 10 ft./lbs. (13Nm) for ⁵/₁₆" , ³/₈" , and ¹/₂" ATR.

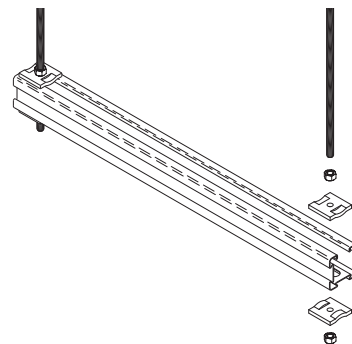

Dimensions are in inches unless otherwise noted. Metric dimensions are in parentheses and are in millimeters unless otherwise noted.

4Dimension Channels

4D22 Channel - 2 1/8" (53.5mm) x 2 1/8" (53.5mm)

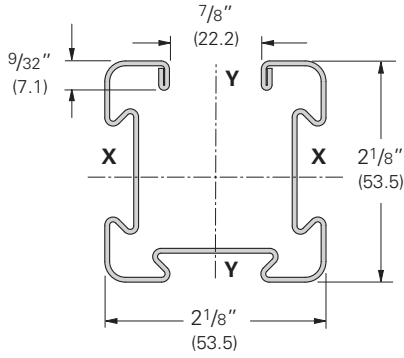

- Thickness: 18 Gauge (1.2mm)
- Standard Lengths: 10' (3.05m) & 20' (6.09m)
- Finish: Plain, DURA GREEN™, Pre-Galvanized, HDG, SS4, SS6
- Bundle Size: 320 ft. (97.6m)
- Bundle Dimensions:
10ft - 11" (279.4mm) x 10 11/16" (271.5mm)
20ft - 11" (279.4mm) x 6 3/8" (161.9mm)
- For use under U.S. Pat. Nos. 9,470,339; 9,580,900; 9,574,589; 9,651,171; 9,683,590; 9,732,887; 9,746,105; 9,790,980; and 9,926,957
- Additional Patent(s) Pending



4D22 Section Properties

Channel	Weight lbs./ft. kg/m	Areas of Section		X - X Axis					Y - Y Axis			
		in. ²	cm ²	Moment of Inertia (I) in. ⁴ cm ⁴	Section Modulus (S) in. ³ cm ³	Radius of Gyration (r) in. cm	Moment of Inertia (I) in. ⁴ cm ⁴	Section Modulus (S) in. ³ cm ³	Radius of Gyration (r) in. cm			
4D22	1.603 (2.39)	0.470	(3.03)	0.262 (10.91)	0.236 (3.87)	0.747 (1.90)	0.280 (11.65)	0.266 (4.36)	0.772 (1.96)			
4D22A	3.206 (4.78)	0.940	(6.06)	1.453 (60.47)	0.690 (11.31)	1.243 (3.16)	0.560 (23.30)	0.532 (8.72)	0.772 (1.96)			

Calculations of section properties are based on metal thicknesses as determined by the AISI Cold-Formed Steel Design Manual.

4Dimension Strut

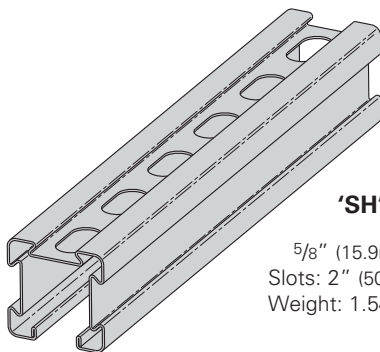

'SH' Hole Pattern

5/8" (15.9mm) x 1 1/4" (31.8mm)
Slots: 2" (50.8mm) centers
Weight: 1.548 lbs./ft. (2.30kg/m)

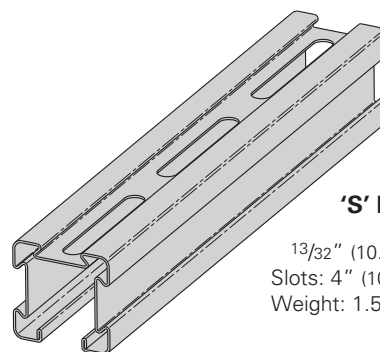

'S' Hole Pattern

13/32" (10.3mm) x 3" (76.2mm)
Slots: 4" (101.6mm) centers
Weight: 1.556 lbs./ft. (2.32kg/m)

Sample Combinations

Various combinations, as shown below, can be assembled in the field by using the 4DDN228 Dual Dove-Tail Nut.

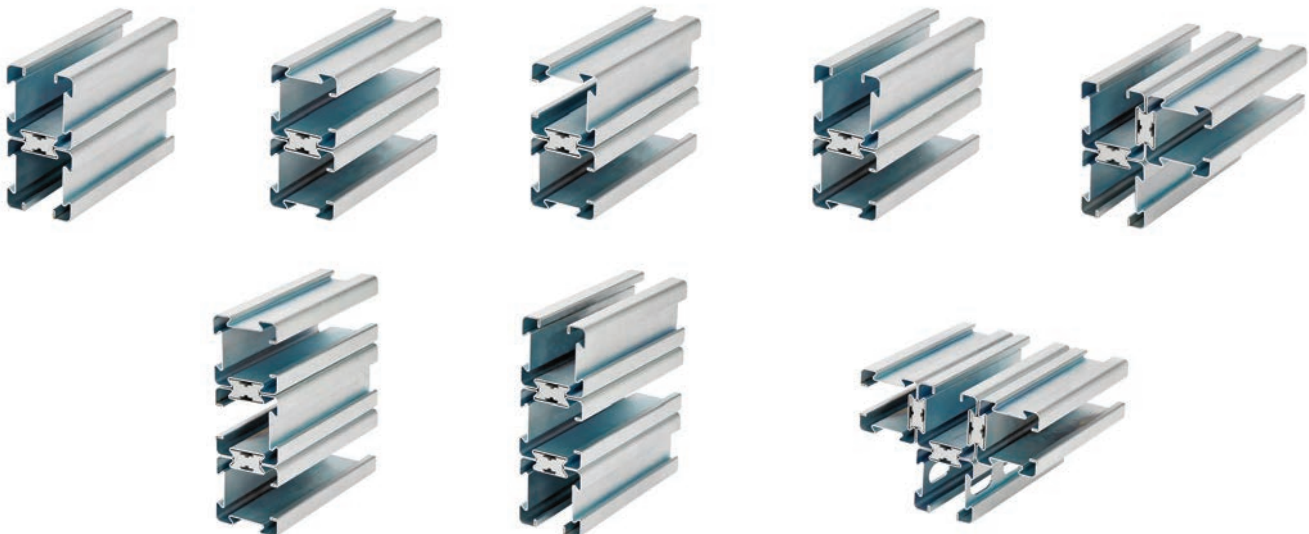

Dimensions are in inches unless otherwise noted. Metric dimensions are in parentheses and are in millimeters unless otherwise noted.

4D22 Channel - 2¹/₈" (53.5mm) x 2¹/₈" (53.5mm) Load Data

Beam Load Data

4D22 Beam Span		Uniform Load		Deflection		Uniform Load @ Deflection =			
In.	mm	Lbs.	kN	In.	mm	1/240 Span		1/360 Span	
						Lbs.	kN	Lbs.	kN
12	(305)	2871	(12.77)	0.05	(1.27)	2871	(12.77)	2523	(11.22)
24	(609)	1872	(8.33)	0.10	(2.54)	1872	(8.33)	1645	(7.31)
36	(914)	1249	(5.55)	0.17	(4.32)	1249	(5.55)	866	(3.85)
48	(1219)	936	(4.16)	0.22	(5.59)	936	(4.16)	649	(2.88)
60	(1524)	749	(3.33)	0.43	(10.92)	480	(2.13)	244	(1.08)
72	(1829)	624	(2.77)	0.52	(13.21)	400	(1.78)	203	(0.90)
84	(2133)	535	(2.38)	0.70	(17.78)	309	(1.37)	184	(0.82)
96	(2438)	468	(2.08)	0.80	(20.32)	270	(1.20)	161	(0.71)
108	(2743)	416	(1.85)	1.00	(25.40)	230	(1.02)	148	(0.66)
120	(3048)	374	(1.66)	1.12	(28.45)	207	(0.92)	133	(0.59)

Based on simple beam condition using test methods according to MFMA standards. To determine concentrated load capacity at mid-span, multiply uniform load by 0.5 and corresponding deflection by 0.8.

Column Load Data

4D22 Unbraced Height		Max. Column Loading K = .80				Max. Column Loading (Loaded @ C.G.)					
In.	mm	Loaded@ C.G.		Loaded@ Slot Face		K = .65		K = 1.0		K = 1.2	
		Lbs.	kN	Lbs.	kN	Lbs.	kN	Lbs.	kN	Lbs.	kN
12	(305)	12105	(53.84)	4900	(21.79)	12177	(54.16)	11888	(52.88)	11502	(51.16)
24	(609)	10690	(47.55)	4623	(20.56)	11321	(50.35)	9791	(43.55)	8940	(39.76)
36	(914)	8792	(39.10)	4087	(18.18)	9829	(43.72)	7210	(32.07)	6113	(27.19)
48	(1219)	7110	(31.62)	3499	(15.56)	8326	(37.03)	5356	(23.82)	4256	(18.93)
60	(1524)	5290	(23.53)	2930	(13.03)	6915	(30.76)	4099	(18.23)	3306	(14.70)
72	(1829)	4188	(18.63)	2508	(11.15)	5400	(24.02)	3344	(14.87)	2676	(11.90)
84	(2133)	3536	(15.73)	2237	(9.95)	4599	(20.45)	2545	(11.32)	2074	(9.22)
96	(2438)	3145	(13.99)	1839	(8.18)	3614	(16.07)	2114	(9.40)	1692	(7.52)
108	(2743)	2381	(10.59)	1607	(7.15)	3024	(13.45)	1807	(8.04)	1417	(6.30)
120	(3048)	1955	(8.69)	1325	(5.89)	2519	(11.20)	1524	(6.78)	1163	(5.17)

**Where the slenderness ratio $\frac{KL}{r}$ exceeds 200, and K = end fixity factor, L = actual length and r = radius of gyration.

4Dimension Channels

Back-To-Back - 4D22 Channel - 2 1/8" (53.5mm) x 4 1/4" (107.0mm) Load Data

Beam Load Data

4D22 Beam Span		Assembly Style	Uniform Load		Deflection		Uniform Load @ 1/240 Span		Uniform Load @ 1/360 Span	
In.	mm		Lbs.	kN	In.	mm	Lbs.	kN	Lbs.	kN
12	(305)	Discontinued	2610	(11.61)	0.07	(1.78)	2490	(11.07)	1282	(5.70)
		4DDN	2610	(11.61)	0.06	(1.52)	2610	(11.61)	2004	(8.91)
		Discontinued	2088	(9.29)	0.07	(1.78)	2088	(9.29)	1549	(6.89)
24	(609)	Discontinued	2610	(11.61)	0.13	(3.30)	2490	(11.07)	1282	(5.70)
		4DDN	2610	(11.61)	0.11	(2.79)	2610	(11.61)	2004	(8.91)
		Discontinued	2088	(9.29)	0.14	(3.55)	2088	(9.29)	1549	(6.89)
36	(914)	Discontinued	2610	(11.61)	0.26	(6.60)	1771	(7.88)	957	(4.25)
		4DDN	2610	(11.61)	0.23	(5.84)	2142	(9.53)	1414	(6.29)
		Discontinued	2088	(9.29)	0.20	(5.08)	1998	(8.89)	1279	(5.69)
48	(1219)	Discontinued	2405	(10.70)	0.35	(8.89)	1632	(7.26)	882	(3.92)
		4DDN	2405	(10.70)	0.31	(7.87)	1974	(8.78)	1303	(5.79)
		Discontinued	1924	(8.56)	0.26	(6.60)	1841	(8.19)	1179	(5.24)
60	(1524)	Discontinued	1924	(8.56)	0.49	(12.44)	1191	(5.30)	763	(3.39)
		4DDN	1924	(8.56)	0.50	(12.70)	1234	(5.89)	828	(3.68)
		Discontinued	1539	(6.84)	0.40	(10.16)	1198	(5.33)	796	(3.54)
72	(1829)	Discontinued	1602	(7.12)	0.59	(14.98)	992	(4.41)	636	(2.83)
		4DDN	1603	(7.13)	0.60	(15.24)	1028	(4.57)	690	(3.07)
		Discontinued	1282	(5.70)	0.48	(12.19)	998	(4.44)	663	(2.95)
84	(2133)	4DDN	1374	(6.11)	0.87	(22.10)	810	(3.60)	549	(2.44)
		Discontinued	1099	(4.89)	0.71	(18.03)	771	(3.43)	513	(2.28)
96	(2438)	4DDN	1202	(5.34)	0.99	(25.14)	620	(2.31)	420	(1.87)
		Discontinued	962	(4.29)	0.81	(20.57)	590	(2.62)	393	(1.75)
108	(2743)	4DDN	1069	(4.75)	1.35	(34.29)	511	(2.27)	342	(1.52)
		Discontinued	855	(3.80)	1.10	(27.94)	490	(2.18)	325	(1.44)
120	(3048)	4DDN	962	(4.28)	1.50	(38.10)	414	(1.84)	277	(1.23)
		Discontinued	770	(3.42)	1.22	(30.99)	397	(1.76)	263	(1.17)

Loading based on 4DDN installed on 24" (609mm) intervals using the 4D22A configuration.



4DDN Assembly
(see page 31 for
product information)

Dimensions are in inches unless otherwise noted. Metric dimensions are in parentheses and are in millimeters unless otherwise noted.

Back-To-Back - 4D22 Channel - 2¹/₈" (53.5mm) x 4¹/₄" (107.0mm) Load Data

Column Load Data

4D22 Unbraced Height		Assembly Style	Max. Column Loading K = .80				Max. Column Loading (Loaded @ C.G.)					
			Loaded @ C.G.		Loaded @ Slot Face		K = .65		K = 1.0		K = 1.2	
In.	mm		Lbs.	kN	Lbs.	kN	Lbs.	kN	Lbs.	kN	Lbs.	kN
12	(305)	See Note	25322	(112.64)	8286	(36.86)	25188	(112.04)	26265	(112.38)	25013	(111.26)
24	(609)	See Note	24634	(109.58)	8112	(36.08)	24878	(110.66)	24380	(108.44)	23660	(105.28)
36	(914)	See Note	23701	(105.43)	7737	(34.42)	24391	(108.49)	22876	(101.76)	21767	(96.82)
48	(1219)	See Note	22259	(99.01)	6701	(29.81)	23019	(102.39)	20792	(92.49)	18624	(82.84)
60	(1524)	See Note	20541	(91.37)	5292	(23.54)	21957	(97.67)	18086	(80.45)	15045	(66.92)
72	(1829)	See Note	18803	(83.64)	4234	(18.83)	21029	(93.54)	15059	(66.98)	11008	(48.97)
84	(2133)	See Note	15966	(71.02)	3409	(15.16)	19131	(85.10)	11406	(50.73)	7971	(35.46)
96	(2438)	See Note	13469	(59.91)	2661	(11.84)	17157	(76.32)	8672	(38.57)	6107	(27.16)
108	(2743)	See Note	10675	(47.48)	2233	(9.93)	15412	(68.56)	6869	(30.55)	4745	(21.11)
120	(3048)	See Note	8564	(38.09)	1735	(7.71)	13014	(57.89)	5495	(24.44)	3805	(16.93)

Note: Loading based on 4DDN installed on 24" (609mm) intervals using the 4D22A configuration.

4Dimension Strut



4DDN Assembly
(see page 31 for
product information)

Dimensions are in inches unless otherwise noted. Metric dimensions are in parentheses and are in millimeters unless otherwise noted.

4Dimension Channels

4D21 Channel - 2 1/8" (53.5mm) x 1 1/16" (26.7mm)

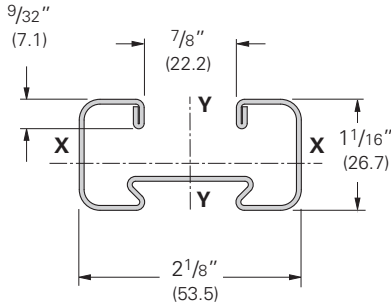

- Thickness: 18 Gauge (1.2mm)
- Standard Lengths: 10' (3.05m) & 20' (6.09m)
- Finish: Plain, DURA GREEN™, Pre-Galvanized, HDG, SS4, SS6
- Bundle Size: 320 ft. (97.6m)
- Bundle Dimensions:
10ft - 11" (279.4mm) x 6 1/2" (165.1mm)
20ft - 11" (279.4mm) x 4 5/16" (109.5mm)
- For use under U.S. Pat. Nos. 9,470,339; 9,580,900; 9,574,589; 9,651,171; 9,683,590; 9,732,887; 9,746,105; 9,790,980; and 9,926,957
- Additional Patent(s) Pending



4D21 Section Properties

Channel	Weight lbs./ft. kg/m	Areas of Section in. ² cm ²	X - X Axis			Y - Y Axis		
			Moment of Inertia (I) in. ⁴ cm ⁴	Section Modulus (S) in. ³ cm ³	Radius of Gyration (r) in. cm	Moment of Inertia (I) in. ⁴ cm ⁴	Section Modulus (S) in. ³ cm ³	Radius of Gyration (r) in. cm
4D21	1.032 (1.54)	0.302 (1.95)	0.042 (1.76)	0.077 (1.26)	0.374 (0.95)	0.167 (6.97)	0.159 (2.60)	0.744 (1.89)
4D21A	2.064 (3.08)	0.605 (3.90)	0.238 (9.89)	0.226 (3.70)	0.627 (1.59)	0.335 (13.95)	0.318 (5.21)	0.744 (1.89)

Calculations of section properties are based on metal thicknesses as determined by the AISI Cold-Formed Steel Design Manual.

4Dimension Strut

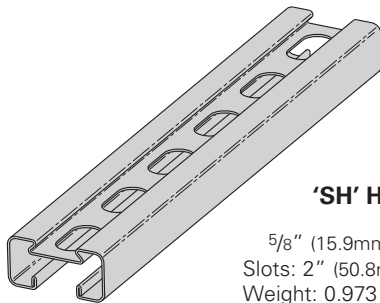

'SH' Hole Pattern

5/8" (15.9mm) x 1 1/4" (31.8mm)
Slots: 2" (50.8mm) centers
Weight: 0.973 lbs./ft. (1.45kg/m)

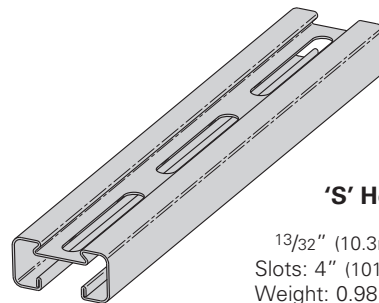

'S' Hole Pattern

1 3/32" (10.3mm) x 3" (76.2mm)
Slots: 4" (101.6mm) centers
Weight: 0.981 lbs./ft. (1.46kg/m)

Sample Combinations

Various combinations, as shown below, can be assembled in the field by using the 4DDN228 Dual Dove-Tail Nut.



Dimensions are in inches unless otherwise noted. Metric dimensions are in parentheses and are in millimeters unless otherwise noted.

4D21 Channel - 2¹/₈" (53.5mm) x 1¹/₁₆" (26.7mm) Load Data

Beam Load Data

4D21 Beam Span		Uniform Load		Deflection		Uniform Load @ 1/240 Span		Deflection = 1/360 Span	
In.	mm	Lbs.	kN	In.	mm	Lbs.	kN	Lbs.	kN
12	(305)	1402	(6.24)	0.10	(2.54)	1085	(4.82)	514	(2.28)
24	(609)	700	(3.11)	0.21	(5.33)	542	(2.41)	257	(1.14)
36	(914)	468	(2.08)	0.34	(8.64)	386	(1.72)	204	(0.91)
48	(1219)	351	(1.56)	0.47	(11.94)	230	(1.02)	150	(0.67)
60	(1524)	280	(1.25)	0.72	(18.29)	173	(0.77)	104	(0.46)
72	(1829)	234	(1.04)	0.96	(24.38)	115	(0.51)	57	(0.25)
84	(2133)	200	(0.89)	1.32	(33.53)	91	(0.40)	45	(0.20)
96	(2438)	175	(0.78)	1.68	(42.67)	67	(0.30)	33	(0.15)
108	(2743)	156	(0.69)	2.15	(54.61)	57	(0.25)	29	(0.13)
120	(3048)	140	(0.62)	2.61	(66.29)	47	(0.21)	24	(0.11)

Based on simple beam condition using test methods according to MFMA standards. To determine concentrated load capacity at mid-span, multiply uniform load by 0.5 and corresponding deflection by 0.8.

Column Load Data

4D21 Unbraced Height	Max. Column Loading K = .80 Loaded @ C.G.	Max. Column Loading (Loaded @ C.G.)							
		Loaded @ Slot Face		K = .65		K = 1.0		K = 1.2	
In. mm	Lbs. kN	Lbs. kN	Lbs. kN	Lbs. kN	Lbs. kN	Lbs. kN	Lbs. kN	Lbs. kN	
12 (305)	9365 (41.65)	3493 (15.53)	9465 (42.10)	9166 (40.77)	8917 (39.66)				
24 (609)	8367 (37.21)	3084 (13.72)	8715 (38.76)	7200 (32.02)	5986 (26.62)				
36 (914)	6045 (26.89)	2410 (10.72)	7430 (33.05)	3998 (17.78)	2792 (12.42)				
48 (1219)	3555 (15.81)	1744 (7.76)	5286 (23.51)	2254 (10.02)	1574 (7.00)				
60 (1524)	2277 (10.13)	1296 (5.76)	3413 (15.18)	1453 (6.46)	1009 (4.49)				
72 (1829)	1585 (7.05)	1006 (4.47)	2424 (10.78)	1020 (4.53)	703** (3.12)				
84 (2133)	1182 (5.26)	797 (3.54)	1762 (7.84)	756** (3.36)	520** (2.31)				
96 (2438)	896** (3.98)	639 (2.84)	1365 (6.07)	567** (2.52)	-- (-)				
108 (2743)	703** (3.12)	535 (2.38)	1081 (4.81)	-- (-)	-- (-)				
120 (3048)	578** (2.57)	443 (1.97)	863** (3.84)	-- (-)	-- (-)				

**Where the slenderness ratio $\frac{KL}{r}$ exceeds 200, and K = end fixity factor, L = actual length and r = radius of gyration.

4Dimension Channels

Back-To-Back - 4D21 Channel - 2 1/8" (53.5mm) x 2 1/8" (153.5mm) Load Data

Beam Load Data

4D21 Beam Span	Assembly Style	Uniform Load		Deflection		Uniform Load @ 1/240 Span		Uniform Load @ 1/360 Span	
		Lbs.	kN	In.	mm	Lbs.	kN	Lbs.	kN
12 (305)	4DDN	1270	(5.65)	0.11	(2.79)	572	(2.54)	328	(1.46)
	4DDN	1270	(5.65)	0.10	(2.54)	752	(3.34)	454	(2.02)
24 (609)	4DDN	1270	(5.65)	0.22	(5.59)	572	(2.54)	328	(1.46)
	4DDN	1270	(5.65)	0.19	(4.82)	752	(3.34)	454	(2.02)
36 (914)	4DDN	1013	(4.50)	0.41	(10.41)	422	(1.88)	262	(1.16)
	4DDN	1013	(4.50)	0.41	(10.41)	424	(1.88)	256	(1.14)
48 (1219)	4DDN	759	(3.37)	0.55	(13.97)	316	(1.40)	196	(0.87)
	4DDN	759	(3.37)	0.55	(13.87)	318	(1.41)	192	(0.85)
60 (1524)	4DDN	608	(2.70)	0.88	(22.35)	199	(0.88)	127	(0.56)
	4DDN	608	(2.70)	0.84	(21.33)	242	(1.07)	168	(0.75)
72 (1829)	4DDN	506	(2.25)	1.06	(26.92)	166	(0.74)	106	(0.47)
	4DDN	506	(2.25)	1.01	(25.65)	201	(0.89)	140	(0.62)
84 (2133)	4DDN	434	(1.93)	1.53	(38.86)	165	(0.73)	112	(0.50)
96 (2438)	4DDN	380	(1.69)	1.75	(44.45)	126	(0.56)	86	(0.38)
108 (2743)	4DDN	338	(1.50)	2.47	(62.74)	101	(0.45)	69	(0.30)
120 (3048)	4DDN	304	(1.35)	2.74	(69.59)	82	(0.36)	56	(0.25)

Loading based on 4DDN installed on 24" (609mm) intervals using the 4D21A configuration.

4Dimension Strut



4DDN Assembly
(see page 31 for
product information)

Dimensions are in inches unless otherwise noted. Metric dimensions are in parentheses and are in millimeters unless otherwise noted.

Back-To-Back - 4D21 Channel - 2¹/₈" (53.5mm) x 2¹/₈" (53.5mm) Load Data

Column Load Data

4D21 Unbraced Height		Assembly Style	Max. Column Loading K = .80				Max. Column Loading (Loaded @ C.G.)					
In.	mm		Loaded @ C.G.		Loaded @ Slot Face		K = .65		K = 1.0		K = 1.2	
			Lbs.	kN	Lbs.	kN	Lbs.	kN	Lbs.	kN	Lbs.	kN
12	(305)	See Note	21287	(94.69)	5930	(26.38)	21601	(96.09)	21123	(93.96)	20584	(91.56)
24	(609)	See Note	19501	(86.74)	5577	(24.80)	20267	(90.15)	18462	(82.12)	17259	(76.77)
36	(914)	See Note	17030	(75.75)	4982	(22.16)	18383	(81.77)	15088	(67.11)	12502	(55.61)
48	(1219)	See Note	14343	(63.80)	4413	(19.63)	16280	(72.41)	10941	(48.67)	7621	(33.90)
60	(1524)	See Note	11290	(50.22)	3944	(17.54)	14430	(64.19)	7191	(31.98)	4907	(21.83)
72	(1829)	See Note	7750	(34.47)	3271	(14.55)	11666	(51.89)	5037	(22.41)	3476	(15.46)
84	(2133)	See Note	5672	(25.23)	2727	(12.13)	8563	(38.09)	3647	(16.22)	2533	(11.27)
96	(2438)	See Note	4411	(19.62)	2292	(10.19)	6685	(29.73)	2805	(11.48)	1941	(8.63)
108	(2743)	See Note	3479	(15.48)	1958	(8.71)	5234	(23.28)	2204	(9.80)	1542**	(6.86)
120	(3048)	See Note	2834	(12.60)	1700	(7.56)	4258	(18.94)	1806	(8.03)	1325**	(5.89)

Note: Loading based on 4DDN installed on 24" (609mm) intervals using the 4D21A configuration.

**Where the slenderness ratio $\frac{KL}{r}$ exceeds 200, and K = end fixity factor, L = actual length and r = radius of gyration.

4Dimension Strut



4DDN Assembly
(see page 31 for product information)

Dimensions are in inches unless otherwise noted. Metric dimensions are in parentheses and are in millimeters unless otherwise noted.

4Dimension Back-To-Back Accessories

4DB - Dove-Tail Bar (Exclusively for 4Dimension™ Strut - Dove-Tail Sides)



- For horizontal applications only
- Recommend 3/8"-16 x 1/2" (12.7mm) long cone point set screw for threaded hole - torque to 4 ft/lbs. (5Nm)
- Bar thickness - 1/2" (12.7mm)
- 1/4"-20 or 3/8"-16 threaded hole; 17/32" (13.5mm) clearance hole
- Spring that locks into slot on 4Dimension channels for easy installation
- Aluminum - clear anodized
- U.S. Pat. Nos. 9,470,339; 9,587,767; and 9,683,590
- Additional Patent(s) Pending

Part No.	Thread Size	Pull-Out Strength		Trapeze Loading		Wt./ft.	
		Lbs.	kN	Lbs.	kN	Lbs.	kN
4DB3-1/4	1/4"-20	690	(3.07)	465	(2.07)	11	(3.39)
4DB3-3/8	3/8"-16	690	(3.07)	465	(2.07)	11	(4.99)
4DB5-1/4	1/4"-20	490	(2.18)	500	(2.22)	19	(8.62)
4DB5-3/8	3/8"-16	490	(2.18)	500	(2.22)	19	(8.62)
4DB7-1/4	1/4"-20	460	(2.04)	425	(1.93)	27	(12.25)
4DB7-3/8	3/8"-16	460	(2.04)	435	(1.93)	27	(12.25)

Safety Factor of 2.5
Loading based on 24" (609mm) span

Back-To-Back Installation

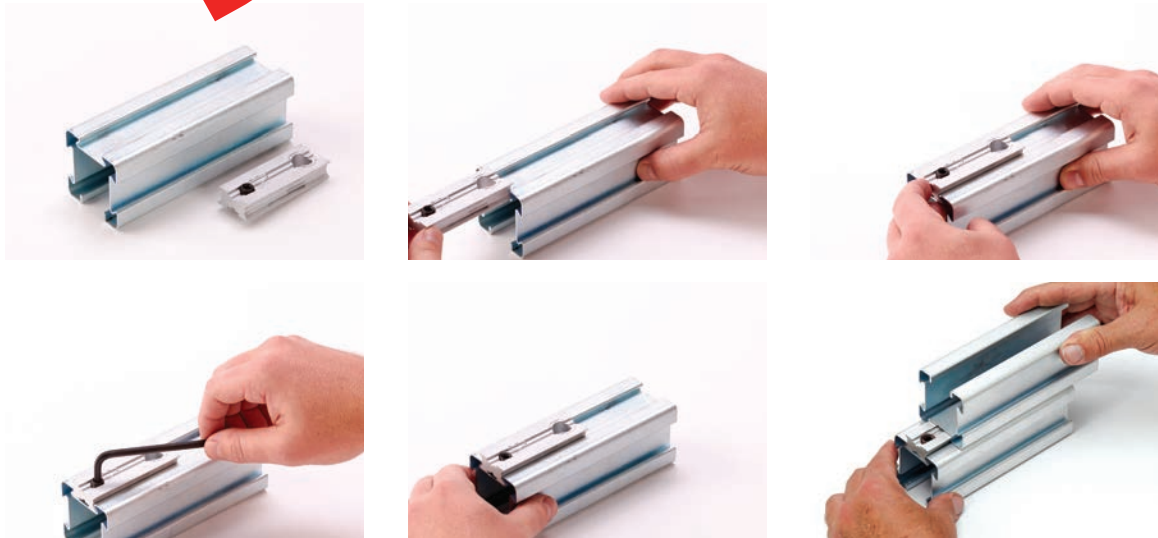

Wall Mount Installation



Dimensions are in inches unless otherwise noted. Metric dimensions are in parentheses and are in millimeters unless otherwise noted.

4Dimension Back-To-Back Accessories

4DDN - Dual Dove-Tail Nut (Exclusively for 4Dimension™ Strut - Dove-Tail Sides)



- One 4Dimension channel must have 'SH' slot pattern
- Torque to 19 ft·lbs (26Nm)
- Zinc or Stainless Steel Type 316 (add SS6 to part number)
- Hex head wrench size - 9/16"
- U.S. Pat. Nos. 9,470,339 and 9,926,957
- Additional Patent(s) Pending

Part No.	Pull-Out Strength		Slip Strength		Wt./C	
	Lbs.	kN	Lbs.	kN	Lbs.	kg
4DDN228	325	(1.44)	55	(0.24)	11.4	(5.17)

Safety Factor of 2.5

Installation

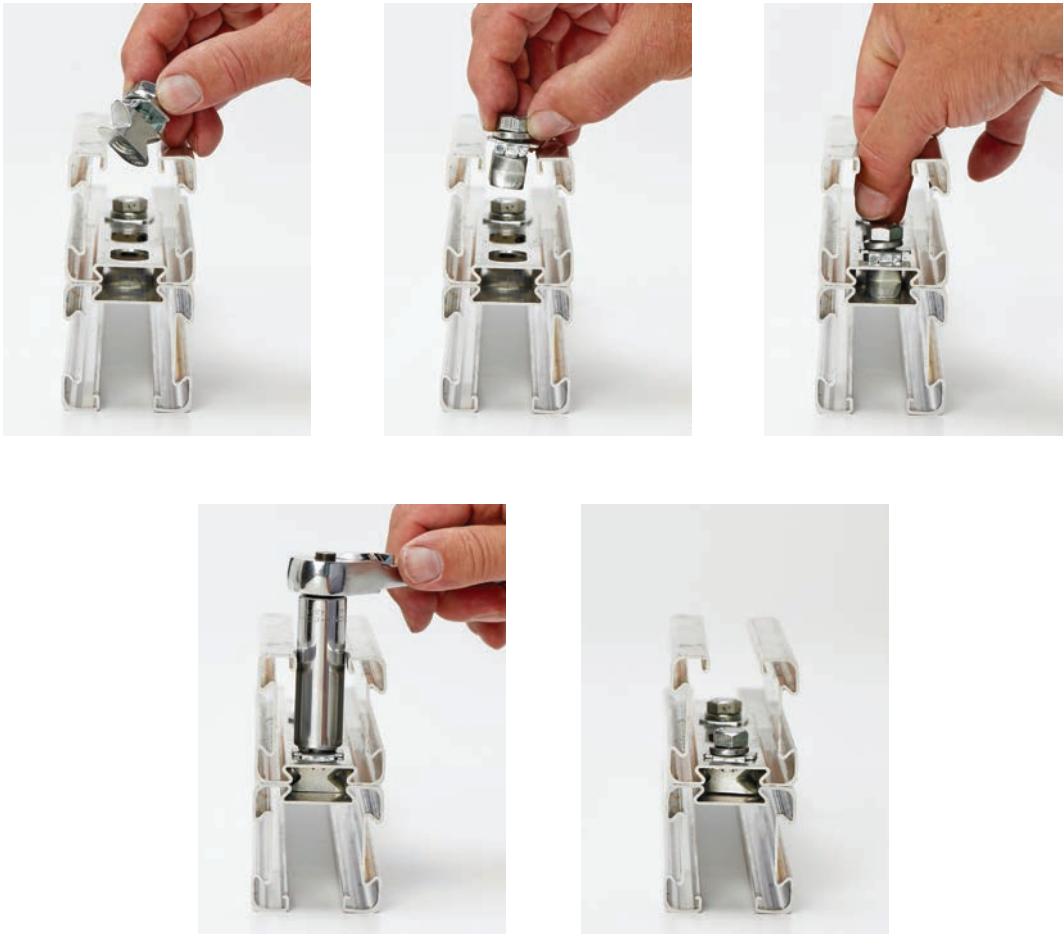

4Dimension Strut

Dimensions are in inches unless otherwise noted. Metric dimensions are in parentheses and are in millimeters unless otherwise noted.

4Dimension Channel Nuts

Nut Type	4Dimension™ Channel		Thread Size			
	4D21	4D22	1/4"-20	5/16"-18	3/8"-16	1/2"-13
4DTN	✓	✓	✓	✓	✓	--
4DSN	✓	✓	✓	✓	✓	--
4DWN *	Discontinued					
4DNW	✓	✓	✓	✓	✓	--
NW Series *	✓	✓	✓	✓	✓	✓
N Series *	✓	✓	✓	✓	✓	✓
N-WO Series *	✓	✓	✓	✓	✓	✓
TN Series *	✓	✓	✓	✓	✓	✓

* Can only be used on open side of 4Dimension channel.

4Dimension Strut



4DTN
Dove-Tail Twirl-Nut™
(page 33)



4DSN
Dove-Tail Slide-In Nut
(page 33)

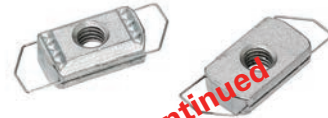

4DWN
Wire Wing Channel Nut
(page 34)



4DNW
Dove-Tail Combo Nut Washer
(page 34)



NW Series
Combo Nut Washer
(page 35)



N-Series
Spring Nut
(page 35)



N-WO Series
Nut Without Spring
(page 36)



TN Series
Twirl-Nut™
(page 36)

Dimensions are in inches unless otherwise noted. Metric dimensions are in parentheses and are in millimeters unless otherwise noted.

4DTN - Dove-Tail Twirl-Nut™ (Exclusively for 4Dimension™ Strut - Dove-Tail Sides)



- U.S. Pat. No. 9,580,900
- For use under U.S. Pat. No. 9,347,213
- Additional Patent(s) Pending

- Used in dove-tail sides only
- Installs with quarter turn
- Recommended bolt length in dove-tail side - 1/2" (12.7mm)
- Zinc plated steel or Stainless Steel Type 316 (add SS6 to part number)
- Safety Factor 3.0
- * Use 85% load factor for stainless steel parts
- ** Use 50% load factor for stainless steel dove tail sides

Part No.	Thread Size	Nut Thickness		Pull-Out Strength*		Slip Strength**		Wt./C	
		In.	mm	Lbs.	kN	Lbs.	kN	Lbs.	kg
4DTN224	1/4"-20	15/64"	(5.9)	400	(1.78)	300	(1.33)	4.4	(1.99)
4DTN223	5/16"-18	15/64"	(5.9)	490	(2.18)	300	(1.33)	4.2	(1.90)
4DTN228	3/8"-16	15/64"	(5.9)	490	(2.18)	350	(1.55)	4.1	(1.86)

Dove-Tail Sides Installation

To achieve catalog load rating, total thread engagement is required.



4DSN - Dove-Tail Slide-In Nut (Exclusively for 4Dimension Strut - All Sides)



- U.S. Pat. No. 9,790,980
- Additional Patent(s) Pending

- Can be used in dove-tail sides (4D21 & 4D22) and open side (4D22)
- Recommended bolt length in dove-tail side - 1/2" (12.7mm)
- Can be used in traditional channel by bending wire down
- Zinc plated steel or Stainless Steel Type 316 (add SS6 to part number)
- Safety Factor 3.0
- Reference instruction sheet for proper assembly and installation
- * Use 85% load factor for stainless steel
- ** Use 30% load factor for stainless steel open side and 50% for dove tail sides

Part No.	Thread Size	Nut Thickness		Pull-Out Strength*		Slip Strength**		Wt./C			
		In.	mm	Open	Dove-Tail	Open	Dove-Tail				
				Lbs.	kN	Lbs.	kN	Lbs.	kg		
4DSN224	1/4"-20	1/4"	(6.3)	450	(2.00)	281	(1.25)	330	(1.47)	7.1	(3.22)
4DSN223	5/16"-18	1/4"	(6.3)	867	(3.85)	489	(2.17)	767	(3.41)	300	(1.33)
4DSN228	3/8"-16	1/4"	(6.3)	883	(3.93)	446	(1.98)	1067	(4.74)	300	(1.33)

To achieve catalog load rating, total thread engagement is required.

Open Side Installation



Dove-Tail Sides Installation

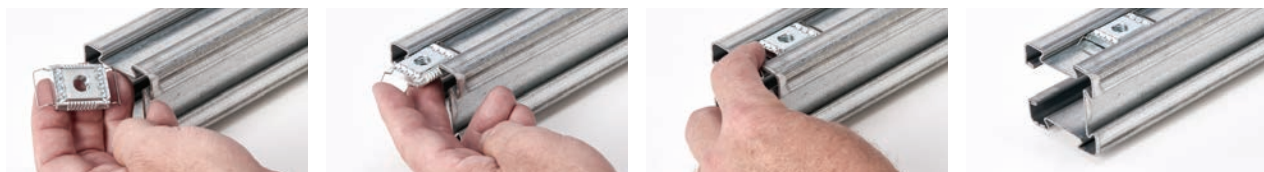

Dimensions are in inches unless otherwise noted. Metric dimensions are in parentheses and are in millimeters unless otherwise noted.

4Dimension Channel Nuts

4DWN - Wire Wing Channel Nut (Exclusively for 4Dimension™ Strut - Open Side)

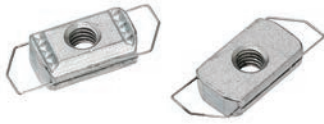

- Used in open side only (4D21 & 4D22)
- Can be used in traditional channel by bending wire down
- Zinc plated steel
- Safety Factor 3

- Patent Pending

Part No.	Thread Size	Nut Thickness		Pull-Out Strength		Slip Strength		Wt./C	
		In.	mm	Lbs.	kN	Lbs.	kN	Lbs.	kg
4DWN224	1/4"-20	23/64"	(9.1)	50	(2.00)	330	(1.47)	8.1	(3.67)
4DWN223	5/16"-18	23/64"	(9.1)	750	(3.33)	450	(2.00)	7.9	(3.58)
4DWN228	3/8"-16	23/64"	(9.1)	850	(3.78)	800	(3.56)	7.7	(3.49)
4DWN225	1/2"-13	23/64"	(9.1)	1020	(4.53)	1250	(5.56)	7.0	(3.17)

Discontinued

Open Side Installation



4Dimension Strut

4DNW - Dove-Tail Combo Nut Washer (Exclusively for 4Dimension Strut - Dove-Tail Side)



- Used in dove-tail side only
- Installs with quarter turn
- To lock combo nut washer in place a hex nut (sold separately) is required
- Zinc plated steel
- Safety Factor 3

- U.S. Pat. No. 9,651,171
- Additional Patent(s) Pending

Part No.	Thread Size	Nut Thickness		Pull-Out Strength		Slip Strength		Wt./C	
		In.	mm	Lbs.	kN	Lbs.	kN	Lbs.	kg
4DNW224	1/4-20	15/64"	(5.9)	400	(1.78)	300	(1.33)	15.3	(6.94)
4DNW223	5/16-18	15/64"	(5.9)	490	(2.18)	300	(1.33)	15.1	(6.85)
4DNW228	3/8-16	15/64"	(5.9)	490	(2.18)	350	(1.55)	14.7	(6.7)

Dove-Tail Side Installation



Dimensions are in inches unless otherwise noted. Metric dimensions are in parentheses and are in millimeters unless otherwise noted.

NW Series - Combo Nut Washer (Traditional Strut & 4Dimension™ Strut - Open Side)



- Used in open side only
- Zinc plated steel or Stainless Steel Type 316 (add SS6 to part number)
- To lock combo nut washer in place a hex nut (sold separately) is required
- Safety Factor 3
- U.S. Pat. No. 7,604,444

* Use 85% load factor for stainless steel

** Use 30% load factor for stainless steel

Part No.	Thread Size	Nut Thickness		Pull-Out Strength*		Slip Strength**		Wt./C	
		In.	mm	Lbs.	kN	Lbs.	kN	Lbs.	kg
NW524	1/4"-20	1/4"	(6.3)	450	(2.00)	330	(1.47)	11.9	(5.40)
NW528	3/8"-16	3/8"	(9.5)	1100	(4.89)	800	(3.56)	13.8	(6.26)
NW525	1/2"-13	3/8"	(9.5)	1275	(5.67)	1500	(6.67)	13.1	(5.94)

Open Side Installation



4Dimension Strut

N Series - Spring Nut (Traditional Strut & 4Dimension Strut - Open Side)



- Used in open side only
- Zinc plated steel or Stainless Steel Type 316 (add SS6 to part number)
- Safety Factor 3

* Use 85% load factor for stainless steel

** Use 30% load factor for stainless steel

Part No.	Thread Size	Nut Thickness		Pull-Out Strength*		Slip Strength**		Wt./C	
		In.	mm	Lbs.	kN	Lbs.	kN	Lbs.	kg
N224	1/4"-20	1/4"	(6.3)	450	(2.00)	330	(1.47)	6.7	(3.04)
N228	3/8"-16	3/8"	(9.5)	1100	(4.89)	800	(3.56)	9.3	(4.22)
N225	1/2"-13	1/2"	(12.7)	1275	(5.67)	1500	(6.67)	11.6	(5.26)

Open Side Installation



Dimensions are in inches unless otherwise noted. Metric dimensions are in parentheses and are in millimeters unless otherwise noted.

4Dimension Channel Nuts

NWO Series - Spring Nut without Spring (Traditional Strut & 4Dimension™ Strut - Open Side)



- Used in open side only
- Zinc plated steel or Stainless Steel Type 316 (add SS6 to part number)
- Safety Factor 3
- * Use 85% load factor for stainless steel
- ** Use 30% load factor for stainless steel

Part No.	Thread Size	Nut Thickness		Pull-Out Strength*		Slip Strength**		Wt./C	
		In.	mm	Lbs.	kN	Lbs.	kN	Lbs.	kg
N224WO	1/4"-20	1/4"	(6.3)	450	(2.00)	330	(1.47)	6.7	(3.04)
N228WO	3/8"-16	3/8"	(9.5)	1100	(4.89)	800	(3.56)	9.3	(4.22)
N225WO	1/2"-13	1/2"	(12.7)	1275	(5.67)	1500	(6.67)	11.6	(5.26)

4Dimension Strut

TN Series - Twirl-Nut™ (Traditional Strut & 4Dimension Strut - Open Side)



- Used in open side only
- Zinc plated steel
- Safety Factor 3

Part No.	Thread Size	Nut Thickness		Pull-Out Strength		Slip Strength		Wt./C	
		In.	mm	Lbs.	kN	Lbs.	kN	Lbs.	kg
TN224	1/4"-20	1/4"	(6.3)	450	(2.00)	330	(1.47)	6.7	(3.04)
TN228	3/8"-16	3/8"	(9.5)	1100	(4.89)	800	(3.56)	9.3	(4.22)
TN225	1/2"-13	1/2"	(12.7)	1275	(5.67)	1500	(6.67)	11.6	(5.26)

Open Side Installation

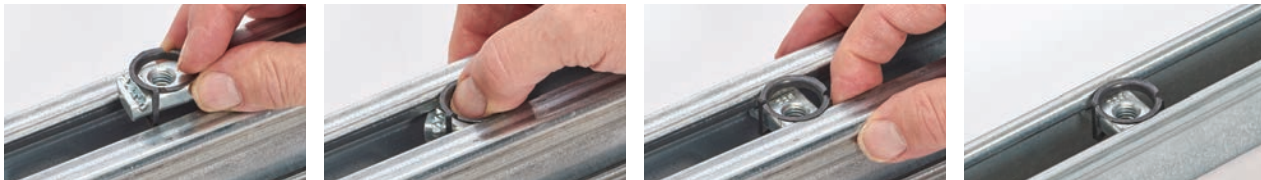

Dimensions are in inches unless otherwise noted. Metric dimensions are in parentheses and are in millimeters unless otherwise noted.

4D2000 Series O.D. Pipe & Conduit Clamps

- Safety Factor of 3 (open side)
Safety Factor of 3 (dove-tail side)
- Add PA to suffix for pre-assembled pipe clamps
- Includes combination recess hex head machine screw and square nut.
- Material: 12 Ga. (2.6)
ASTM A653 33,000 PSI min. yield
- Standard finishes: ZN, HDG, SS4, SS6, DCU, AL
- See page 39 for UL Listed (**U**) clamps.
- U.S. Pat. Nos. 9,546,744; 9,746,105; and 9,989,169
- Additional Patent(s) Pending

Universal Pipe Clamps (Interchangeable With 4Dimension™ & Traditional Strut In Dove-Tail & Open Sides)

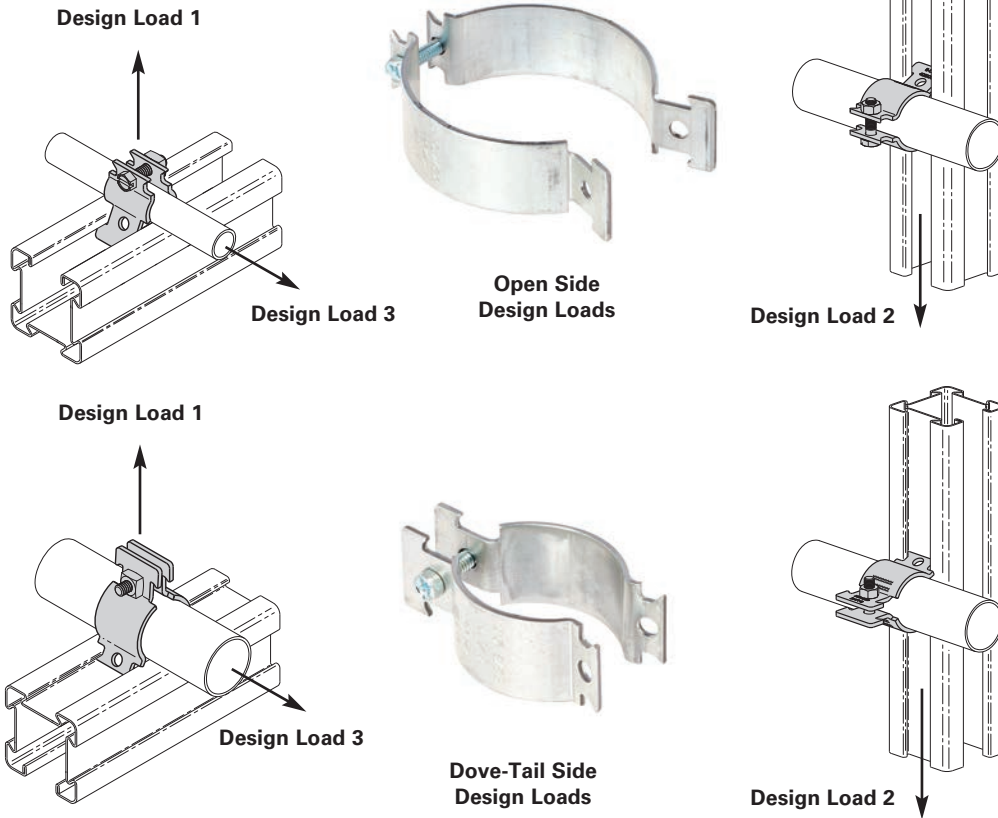

Open Side Installation



Dove-Tail Side Installation



Dimensions are in inches unless otherwise noted. Metric dimensions are in parentheses and are in millimeters unless otherwise noted.

4Dimension Pipe Clamps

Universal Pipe Clamps

(Interchangeable With 4Dimension™ & Traditional Strut
In Dove-Tail & Open Sides)

Part No.	O.D. Tubing Size		EMT Conduit Size		Rigid Conduit Size		Copper Tubing Size		Hardware Size	Clamp Weight Per 100 Pair	*† Wt. Per 100 ft. (30.5m)		** Wt. Per 100 ft. (30.5m)		
	in.	(mm)	in.	(mm)	in.	(mm)	in.	(mm)			Lbs.	(kg)	Lbs.	(kg)	Lbs.
4D2023	1/4"	(6.3)	--	--	--	--	--	--	1/4"-20	8	(3.6)	15.0†	(6.8)	--	(--)
4D2024	3/8"	(9.5)	--	--	--	--	1/4"	(6)	1/4"-20	8	(3.6)	27.4†	(12.4)	17.7	(8.0)
4D2025	1/2"	(12.7)	--	--	--	--	3/8"	(10)	1/4"-20	9	(4.1)	50.2†	(22.8)	32.4	(14.7)
4D2026	5/8"	(15.9)	--	--	--	--	1/2"	(15)	1/4"-20	10	(4.5)	69.5†	(31.5)	43.9	(19.0)
4D2000	--	--	3/8"	(10)	--	--	--	--	1/4"-20	10	(4.5)	36.6*	(16.6)	--	(--)
4D2001	--	--	1/2"	(15)	3/8"	(10)	--	--	1/4"-20	10	(4.5)	65.1*	(29.5)	--	(--)
4D2027	3/4"	(19.0)	--	--	--	--	--	--	1/4"-20	10	(4.5)	89.5†	(40.6)	--	(--)
4D2008	7/8"	(22.2)	--	--	1/2"	(15)	3/4"	(20)	1/4"-20	11	(5.0)	101.1*	(45.9)	83.0	(37.6)
4D2002	--	--	3/4"	(20)	--	--	--	--	1/4"-20	11	(5.0)	84.3*	(38.2)	--	(--)
4D2009	1"	(25.4)	--	--	3/4"	(20)	--	--	1/4"-20	15	(6.8)	145.8*	(66.1)	--	(--)
4D2030	1 1/8"	(28.6)	--	--	--	--	1"	(25)	1/4"-20	15	(6.8)	166.8†	(75.6)	117.7	(53.3)
4D2003	--	--	1"	(25)	--	--	--	--	1/4"-20	16	(7.2)	130.3*	(59.1)	--	(--)
4D2031	1 1/4"	(31.7)	--	--	--	--	--	--	1/4"-20	16	(7.2)	192.5†	(87.3)	--	(--)
4D2010	1 3/8"	(34.9)	--	--	1"	(25)	1 1/4"	(32)	1/4"-20	17	(7.7)	219.3*	(99.5)	156.8	(71.1)
4D2004	1 1/2"	(38.1)	1 1/4"	(32)	--	--	--	--	1/4"-20	19	(8.6)	212.3*	(96.3)	--	(--)
4D2011	1 5/8"	(41.3)	--	--	1 1/4"	(32)	1 1/2"	(40)	1/4"-20	19	(8.6)	318.3*	(144.4)	210.7	(95.6)
4D2005	1 3/4"	(44.4)	1 1/2"	(40)	--	--	--	--	1/4"-20	28	(12.7)	269.8*	(122.4)	--	(--)
4D2012	1 7/8"	(47.6)	--	--	1 1/2"	(40)	--	--	1/4"-20	30	(13.6)	408.8*	(185.4)	--	(--)
4D2037	2"	(50.8)	--	--	--	--	--	--	1/4"-20	30	(13.6)	370.8†	(168.2)	--	(--)
4D2038	2 1/8"	(54.0)	--	--	--	--	2"	(50)	1/4"-20	32	(14.5)	451.5†	(204.8)	336.6	(152.7)
4D2006	--	--	2"	(50)	--	--	--	--	1/4"-20	33	(14.9)	401.8*	(182.3)	--	(--)
4D2039	2 1/4"	(57.1)	--	--	--	--	--	--	1/4"-20	32	(14.5)	476.8†	(216.3)	--	(--)
4D2013	2 3/8"	(60.3)	--	--	2"	(50)	--	--	1/4"-20	34	(15.4)	479.5*	(217.5)	--	(--)
4D2041	2 1/2"	(63.5)	--	--	--	--	--	--	1/4"-20	35	(15.9)	553.5†	(251.0)	--	(--)
4D2042	2 5/8"	(66.7)	--	--	--	--	2 1/2"	(65)	1/4"-20	35	(15.9)	593.5†	(269.2)	454.6	(206.2)
4D2043	2 3/4"	(69.8)	--	--	--	--	--	--	1/4"-20	38	(17.2)	634.3†	(287.7)	--	(--)
4D2014	2 7/8"	(73.0)	2 1/2"	(65)	2 1/2"	(65)	--	--	1/4"-20	38	(17.2)	737.7*	(334.6)	--	(--)
4D2045	3"	(76.2)	--	--	--	--	--	--	1/4"-20	38	(17.2)	874.1†	(396.5)	--	(--)
4D2046	3 1/8"	(79.4)	--	--	--	--	3"	(80)	1/4"-20	39	(17.7)	925.4†	(419.7)	628.0	(284.8)
4D2047	3 1/4"	(82.5)	--	--	--	--	--	--	1/4"-20	41	(18.6)	978.0†	(443.6)	--	(--)
4D2048	3 3/8"	(85.7)	--	--	--	--	--	--	1/4"-20	43	(19.5)	1115.7†	(506.1)	--	(--)
4D2015	3 1/2"	(88.9)	3"	(80)	3"	(80)	--	--	1/4"-20	44	(20.0)	1007.0*	(456.8)	--	(--)
4D2050	3 5/8"	(92.1)	--	--	--	--	3 1/2"	(90)	1/4"-20	54	(24.5)	1233.5†	(559.5)	828.1	(375.6)
4D2051	3 3/4"	(95.1)	--	--	--	--	--	--	1/4"-20	57	(25.8)	1294.0†	(586.9)	--	(--)
4D2052	3 7/8"	(98.4)	--	--	--	--	--	--	1/4"-20	55	(25.0)	1355.6†	(614.9)	--	(--)
4D2016	4"	(101.6)	3 1/2"	(90)	3 1/2"	(90)	--	--	1/4"-20	57	(25.8)	1674.8*	(759.6)	--	(--)
4D2017	4 1/2"	(114.3)	4"	(100)	4"	(100)	--	--	1/4"-20	60	(27.2)	1967.0*	(892.2)	--	(--)

* Weight of conduit/tubing and conductors per 100 ft. (30.5m). Where clamp size fits multiple conduit/pipe sizes the weight is for the heaviest size.

** Weight of copper tubing and water per 100 ft. (30.5m).

† Weight of OD tubing and water per 100 ft. (30.5m) based on the mid-range tubing thicknesses.

Dimensions are in inches unless otherwise noted. Metric dimensions are in parentheses and are in millimeters unless otherwise noted.

4Dimension Pipe Clamps

Universal Pipe Clamps (Interchangeable With 4Dimension™ & Traditional Strut In Dove-Tail & Open Sides)

Part No.	Design Load 1 ^Δ		Design Load 2 ^Δ		Design Load 3 ^Δ	
	Open Side Lbs. (kN)	Dove-Tail Side Lbs. (kN)	Open Side Lbs. (kN)	Dove-Tail Side Lbs. (kN)	Open Side Lbs. (kN)	Dove-Tail Side Lbs. (kN)
4D2023	800 (3.56)	300 (1.33)	80 (0.35)	80 (0.35)	65 (0.29)	65 (0.29)
4D2024	800 (3.56)	300 (1.33)	80 (0.35)	80 (0.35)	65 (0.29)	65 (0.29)
4D2025	800 (3.56)	300 (1.33)	80 (0.35)	80 (0.35)	65 (0.29)	65 (0.29)
4D2026	800 (3.56)	300 (1.33)	80 (0.35)	80 (0.35)	65 (0.29)	65 (0.29)
4D2000	800 ^U (3.56)	300 ^U (1.33)	80 (0.35)	80 (0.35)	65 (0.29)	65 (0.29)
4D2001	800 ^U (3.56)	300 ^U (1.33)	80 (0.35)	80 (0.35)	65 (0.29)	65 (0.29)
4D2027	800 (3.56)	300 (1.33)	80 (0.35)	80 (0.35)	65 (0.29)	65 (0.29)
4D2008	800 ^U (3.56)	300 ^U (1.33)	80 (0.35)	80 (0.35)	65 (0.29)	65 (0.29)
4D2002	800 ^U (3.56)	300 ^U (1.33)	80 (0.35)	80 (0.35)	65 (0.29)	65 (0.29)
4D2009	800 ^U (3.56)	300 ^U (1.33)	80 (0.35)	80 (0.35)	65 (0.29)	65 (0.29)
4D2030	800 (3.56)	400 (1.78)	100 (0.44)	80 (0.35)	100 (0.44)	65 (0.29)
4D2003	800 ^U (3.56)	400 ^U (1.78)	100 (0.44)	80 (0.35)	100 (0.44)	65 (0.29)
4D2031	800 (3.56)	400 (1.78)	100 (0.44)	80 (0.35)	100 (0.44)	65 (0.29)
4D2010	800 (3.56)	400 (1.78)	100 (0.44)	80 (0.35)	100 (0.44)	65 (0.29)
4D2004	800 ^U (3.56)	400 ^U (1.78)	100 (0.44)	80 (0.35)	100 (0.44)	65 (0.29)
4D2011	800 ^U (3.56)	400 ^U (1.78)	100 (0.44)	80 (0.35)	100 (0.44)	65 (0.29)
4D2005	800 ^U (3.56)	400 ^U (1.78)	100 (0.44)	85 (0.38)	100 (0.44)	70 (0.31)
4D2012	800 ^U (3.56)	400 ^U (1.78)	100 (0.44)	85 (0.38)	100 (0.44)	70 (0.31)
4D2037	800 (3.56)	400 (1.78)	100 (0.44)	85 (0.38)	100 (0.44)	70 (0.31)
4D2038	800 (3.56)	400 (1.78)	100 (0.44)	85 (0.38)	100 (0.44)	70 (0.31)
4D2006	800 ^U (3.56)	400 ^U (1.78)	100 (0.44)	85 (0.38)	100 (0.44)	70 (0.31)
4D2039	1000 (4.45)	400 (1.78)	80 (0.35)	80 (0.35)	80 (0.35)	70 (0.31)
4D2013	1000 ^U (4.45)	400 ^U (1.78)	80 (0.35)	80 (0.35)	80 (0.35)	70 (0.31)
4D2041	1000 (4.45)	400 (1.78)	80 (0.35)	80 (0.35)	80 (0.35)	70 (0.31)
4D2042	1000 (4.45)	400 (1.78)	80 (0.35)	80 (0.35)	80 (0.35)	70 (0.31)
4D2043	1000 (4.45)	400 (1.78)	80 (0.35)	80 (0.35)	80 (0.35)	70 (0.31)
4D2014	1000 ^U (4.45)	400 ^U (1.78)	80 (0.35)	80 (0.35)	80 (0.35)	70 (0.31)
4D2045	1000 (4.45)	400 (1.78)	80 (0.35)	80 (0.35)	80 (0.35)	70 (0.31)
4D2046	1000 (4.45)	400 (1.78)	80 (0.35)	80 (0.35)	80 (0.35)	70 (0.31)
4D2047	1000 (4.45)	400 (1.78)	80 (0.35)	80 (0.35)	80 (0.35)	70 (0.31)
4D2048	1000 (4.45)	400 (1.78)	80 (0.35)	80 (0.35)	80 (0.35)	70 (0.31)
4D2015	1000 ^U (4.45)	400 ^U (1.78)	80 (0.35)	80 (0.35)	80 (0.35)	70 (0.31)
4D2050	1000 (4.45)	400 (1.78)	80 (0.35)	80 (0.35)	80 (0.35)	70 (0.31)
4D2051	1000 (4.45)	400 (1.78)	80 (0.35)	80 (0.35)	80 (0.35)	70 (0.31)
4D2052	1000 (4.45)	400 (1.78)	80 (0.35)	80 (0.35)	80 (0.35)	70 (0.31)
4D2016	1000 ^U (4.45)	400 ^U (1.78)	80 (0.35)	80 (0.35)	80 (0.35)	70 (0.31)
4D2017	1000 ^U (4.45)	300 ^U (1.33)	60 (0.26)	80 (0.35)	80 (0.35)	70 (0.31)

^Δ Safety factor of 3 on open slot and dove tail slot.
Applies to 4D2000 series Universal Pipe Clamps
used in 4D21, 4D22, or traditional strut channels

^U For UL installations, follow Table 9 in UL2239.

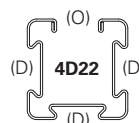
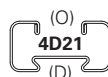

(O) Open Side
(D) Dove Tail Side(s)

Dimensions are in inches unless otherwise noted. Metric dimensions are in parentheses and are in millimeters unless otherwise noted.

4Dimension Accessories

4D5000 - Flip Clip™ Trapeze Hanger

(Exclusively for 4Dimension™ Strut)



- Mechanically locks in place when used with 4Dimension SH hole pattern channel *
- Recommend a self-tapping set screw when used in 4Dimension solid channel or 'S' hole pattern channel
- Requires hex nut for location placement on ATR
- Provides more usable area for trapeze application
- Sold in pieces (when used as trapeze hangers, two pieces are required)
- Loading Safety Factor: 2.5
- Zinc plated steel or Stainless Steel Type 316 (add SS6 to part number)
- U.S. Pat. No. 9,574,589; 10,012,255
- Additional Patent(s) Pending

Part No.	Rod Size	Design Load		Wt./C	
		Lbs.	kN	Lbs.	kg
4D5000-3/8	3/8"-16	770	(3.42)	23.8	(10.79)
4D5000-1/2	1/2"-13	880	(3.56)	25.3	(11.47)

Design load when used in pairs as a trapeze solution.
Consult beam loading charts for channel loading.

Installation (shown in the upright position)

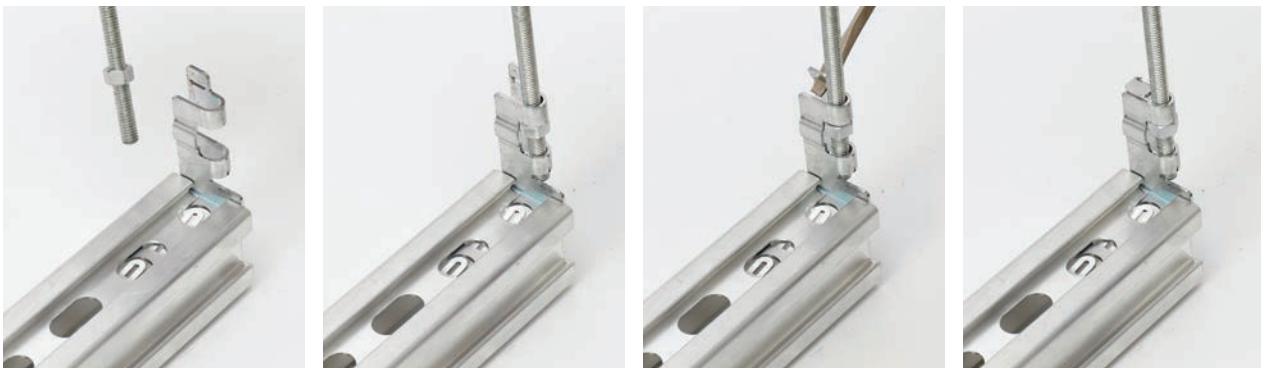
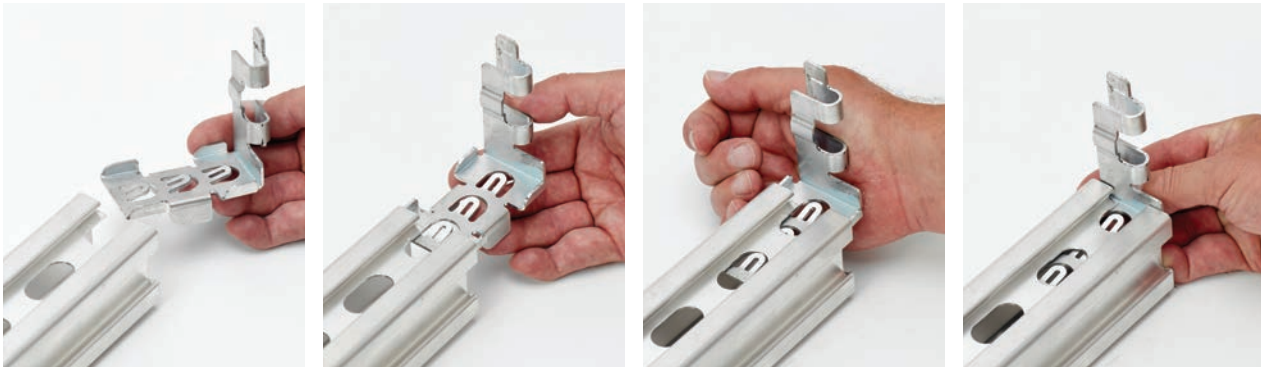

Ensure both top and bottom lock tabs are bent to secure All Threaded Rod.

* Helps ensure the tab on the horizontal side is bent to engage in the SH slot.

Dimensions are in inches unless otherwise noted. Metric dimensions are in parentheses and are in millimeters unless otherwise noted.

4D5001 - 2-Piece Turn & Lock Trapeze Hanger (Exclusively for 4Dimension™ Strut)

- Can be installed in any desired position on the ATR, helping eliminate the need to thread hex nuts up along ATR
- No additional hardware required
- Used in 'SH' slot with open face of channel facing up or down
- Interlocking/alignment tabs on top of part for easy assembly, installation, and adjustment
- Sold in pairs as shown below (one left side and one right side)
- When used as trapeze hangers, two sets are required
- Loading Safety Factor: 2.5
- U.S. Pat. No. 9,458,952
- For use under U.S. Pat. No. 9,732,887



Note:
Not to be used in continuous open slot or solid dove-tail slot.

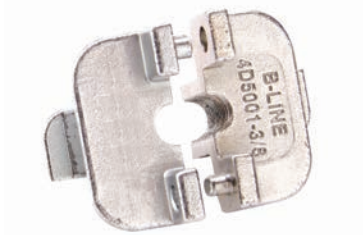

**Left & Right Sides
(one pair as shown)**

Part No.	Thread Size	Loading		Wt./C	
		Lbs.	kN	Lbs.	kg
4D5001	$3/8''-16$	1155	(5.14)	24.8	(11.25)

Design load when used in pairs as a trapeze solution.
Consult beam loading charts for channel loading.

Installation

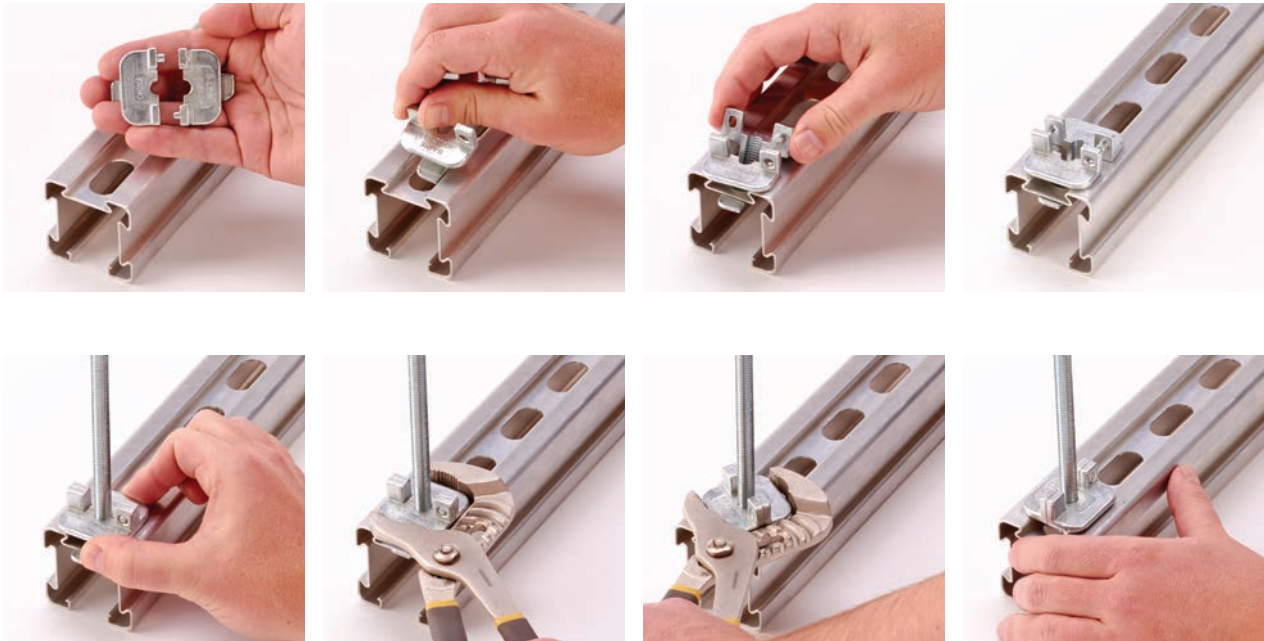

Dimensions are in inches unless otherwise noted. Metric dimensions are in parentheses and are in millimeters unless otherwise noted.

4Dimension Accessories

4D5100 - 2 Piece Strengthening Clamp

(Exclusively for 4Dimension™ Strut)



- For use on 4D22 channel only
- Shipped as one piece that can be snapped apart for installation
- Also designed to be used as a rod hanger
- Loading Safety Factor: 2.5
- Pre-Galv steel or Stainless Steel Type 316 (add SS6 to part number)
- U.S. Pat. No. 9,453,592; 9,982,837
- Additional Patent(s) Pending

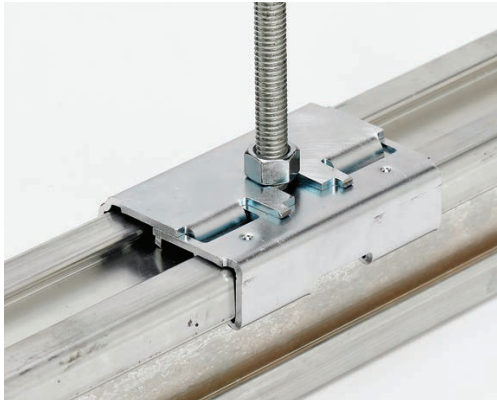

Part No.	Thread Size	Wt./C	
		Lbs.	kg
4D5100-3/8	3/8"-16	44.1	(20.00)
4D5100-1/2	1/2"-13	43.9	(19.91)

Part No.	Loading	
	Lbs.	kN
4D5100-3/8	785	(3.49)
4D5100-1/2	935	(4.16)

Design load when used individually.
Consult beam loading charts for channel loading.

4Dimension Strut

Installation



Dimensions are in inches unless otherwise noted. Metric dimensions are in parentheses and are in millimeters unless otherwise noted.

4Dimension Accessories

4D280 Post Bases

(Exclusively for 4Dimension™ Strut)

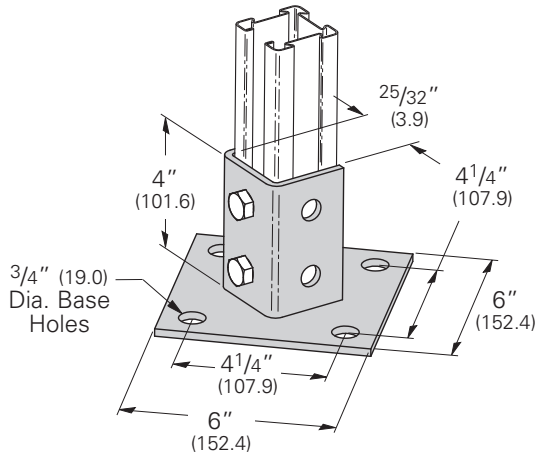

- Standard finishes: ZN, GRN, HDG, SS4
- Used with 4D22 and 4D21



Part No.	Wt./C	
	Lbs.	kg
4D280	365	(165.5)

4D280SQ Post Bases

(Exclusively for 4Dimension Strut)

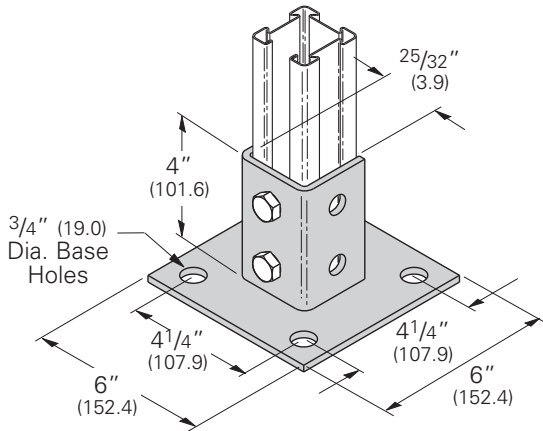

- Standard finishes: ZN, GRN, HDG, SS4
- Used with 4D22 and 4D21



Part No.	Wt./C	
	Lbs.	kg
4D280SQ	365	(165.5)

4D280FL Post Bases

(Exclusively for 4Dimension Strut)

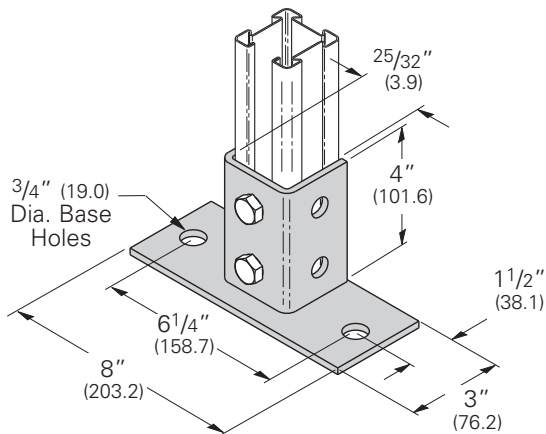

- Standard finishes: ZN, GRN, HDG, SS4
- Used with 4D22 and 4D21



Part No.	Wt./C	
	Lbs.	kg
4D280FL	296	(134.2)

Dimensions are in inches unless otherwise noted. Metric dimensions are in parentheses and are in millimeters unless otherwise noted.

4Dimension Accessories

4D441 Series - Universal Beam Clamps (Interchangeable With 4Dimension™ & Traditional Strut)

Part No.	Fits Channel Sizes	U-Bolt Length		Wt./C	
		in.	mm	Lbs.	kg
4D441-21	4D21, B52, B54	3 ⁵ / ₃₂ "	(80.1)	102	(46.3)
4D441-22	4D22 & 4D21A Style B22, B24, B52A, B54A	4 ⁵ / ₃₂ "	(105.5)	107	(48.5)
4D441-22A	4D22 Back-To-Back Style B22A, B24A, B11	6 ¹ / ₃₂ "	(153.2)	116	(52.6)



For Use With 4Dimension Strut



For Use With Traditional Strut

- Designed to be used with 4Dimension and traditional strut
- Design Load 1200 lbs. (5.34kN) when used in pairs
- Safety Factor of 3
- 3/4" (19.0mm) maximum flange thickness
- Recommended torque: 150 in-lbs. (16.9N•m)
- U-Bolt comes pre-assembled with hardware
- Sold in pieces
- Standard finishes: Zinc Plated, HDG, SS4
- U.S. Pat. No. 10,100,861
- Other Patents Pending

4Dimension Strut

4Dimension Strut

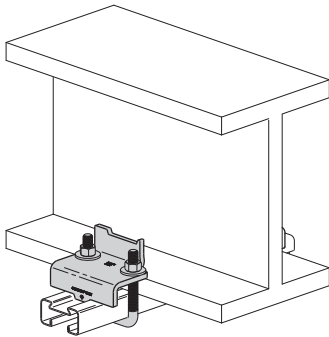

4D441-21

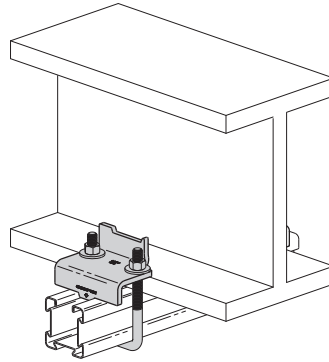

4D441-22

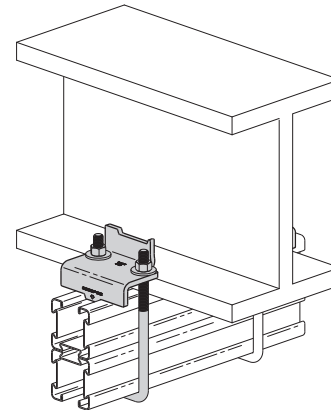

4D441-22A

Traditional Strut

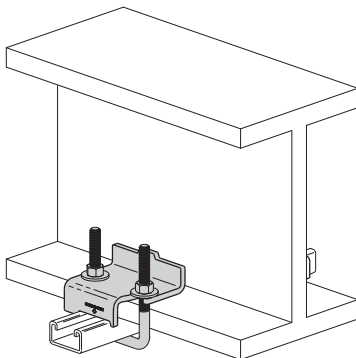

4D441-21

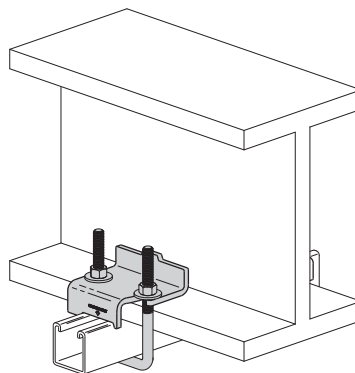

4D441-22

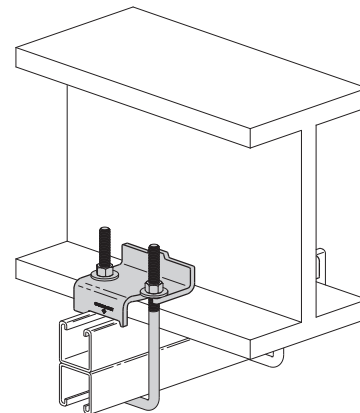

4D441-22A

Dimensions are in inches unless otherwise noted. Metric dimensions are in parentheses and are in millimeters unless otherwise noted.

4Dimension Accessories

4D441 Series - Universal Beam Clamps (Interchangeable With 4Dimension™ & Traditional Strut) cont.

Installation



Compatible with Traditional Strut



Ensure that the U-Bolt is fully secured/nested in beam clamp slot.

4Dimension Strut

4D822 & 4D821 - End Caps

- Sized for 4D22 and 4D21 channels
- Available in: White (W), Black (BLK), Green (GRN), Yellow (Y), Gray (GRY)
- Material: PVC/Vinyl/Polyvinyl Chloride
- Withstands intermittent temperatures up to 350° F (177°C) and 200°F (93°C) continuous
- Packaging quantities: 50 per box



4D822

4D821

Part No.	Use With	Wt./C	
		Lbs.	kg
4D821	4D21	1.5	(0.68)
4D822	4D22	2.0	(0.91)

Dimensions are in inches unless otherwise noted. Metric dimensions are in parentheses and are in millimeters unless otherwise noted.

4Dimension Photos

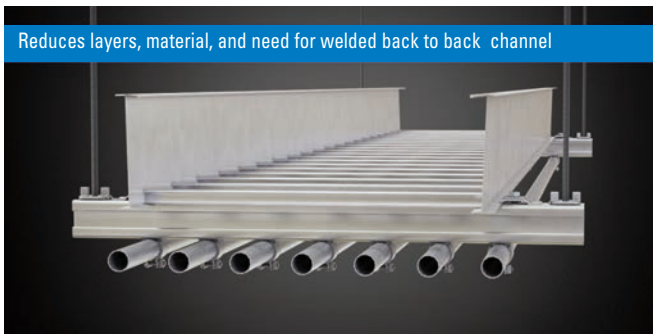
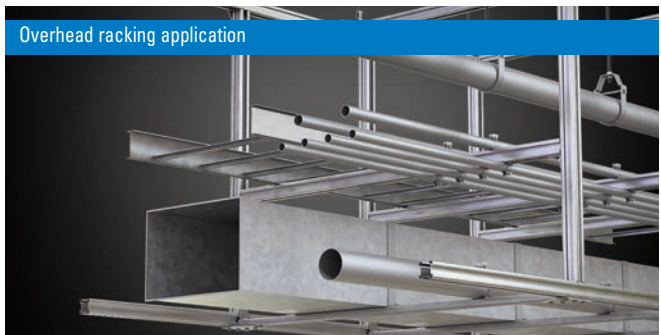
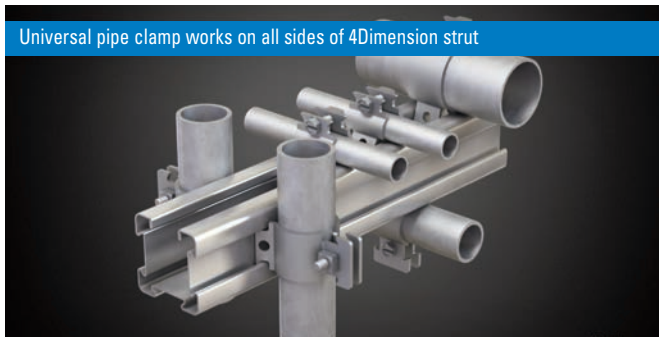

Dimensions are in inches unless otherwise noted. Metric dimensions are in parentheses and are in millimeters unless otherwise noted.

Hydraulic Strut Cutter

(For 4Dimension™ Strut & Various Traditional Channels)

- Patented **esp*** hydraulic strut cutter easily cuts 4Dimension strut and a variety of B-Line series strut profiles to size in seconds
- Produces clean cuts without burrs or sharp edges - no post processing necessary
- Lightweight, black anodized 7075-T651 aluminum frame is portable to the jobsite - 65 lbs. (29.4kg)
- Collapsible handle creates a sturdy operations platform
- 10,000psi hydraulic power source and hose with universal coupling (sold separately) required for operation
- Adjustable material rest* feeds strut sections straight into cutter
- Adjustable backstop* provides for easy production cutting
- Die sets available for cutting 4D21, 4D22, B22, B24, B26, B52, B54, B56 strut profiles
- Die life: thousands of cuts from a single set of blades

*requires two (2) sections of 1" OD tubing - sold separately



* **esp** (edwards strut pro) is a product logo used by Edwards Manufacturing Company

Part No.	Description	Wt./C	
		Lbs.	kg
BHSC100	Complete esp set includes cutter, hydraulic pump & hose, material rest, backstop and the three (3) die sets listed below	173	(78.5)
Die Sets for Channel			
BHSC100B22	B22, B24, B26, B52, B54, B56	13	(5.9)
BHSC1004D22	4D22	13	(5.9)
BHSC1004D21	4D21	13	(5.9)



4Dimension Strut

Metal Framing Channels

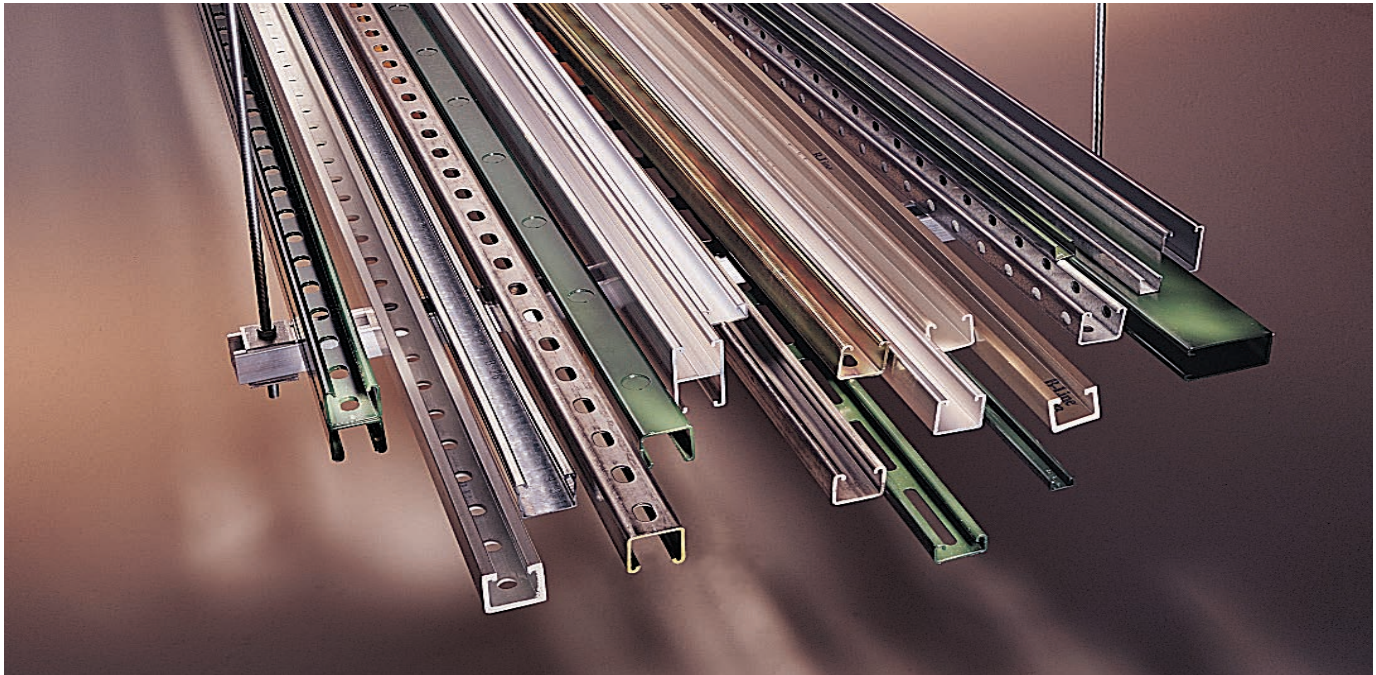

Channel

Metal framing channel is cold formed on our modern rolling mills from 12 Ga. (2.6mm) and 14 Ga. (1.9mm) low carbon steel strips. A continuous slot with inturned lips provides the ability to make attachments at any point.

Lengths & Tolerances

All channels excluding 'SH' style $\pm 1/8"$ (3.2mm) on 10' (3.05m) and $\pm 3/16"$ (4.76mm) on 20' (6.09m)
 All 'SH' channels only $\pm 1/4"$ (6.35mm) on 10' (3.05m) and $\pm 1/2"$ (12.70mm) on 20' (6.09m)
 Custom lengths are available upon request.

Slots

Slotted series of channels offer full flexibility. A variety of pre-punched slot patterns eliminate the need for precise field measuring for hole locations. Slots offer wide adjustments in the alignment and bolt sizing.

Holes

A variety of pre-punched $9/16"$ (14.3 mm) diameter hole patterns are available in our channels. These hole patterns provide an economical alternative to costly field drilling required for many applications.

Knockouts

When used with series B217-20 Closure Strips, knockout channels can be used to provide an economical U.L. listed surface raceway. Channels are furnished with $7/8"$ (22.2 mm) knockouts on 6" (152 mm) centers, allowing for perfect fixture alignment on spans up to 20' (6.09 m).

Materials & Finishes (Unless otherwise noted)

Steel: Plain & Pre-galvanized

12 Ga. (2.6) and 14 Ga. (1.9)

Note: A minimum order may apply on special material and finishes.

Design Load (Steel & Stainless Steel)

The design loads given for strut beam loads are based on a simple beam condition using an allowable stress of 25,000 psi. This allowable stress results in a safety factor of 1.68. This is based upon virgin steel minimum yield strength of 33,000 psi cold worked during rolling to an average yield stress of 42,000 psi. For aluminum channel loading multiply steel loading by a factor of 0.38.

Finish Code	Finish	Specification
PLN	Plain	ASTM A1011, 33,000 PSI min. yield
GRN	DURA GREEN™	
GLV	Pre-Galvanized	ASTM A653 33,000 PSI min. yield
HDG	Hot-Dipped Galvanized	ASTM A123
YZN	Yellow Zinc Chromate	ASTM B633 SC3 Type II
SS4	Stainless Steel Type 304	ASTM A240
SS6	Stainless Steel Type 316	ASTM A240
AL	Aluminum	Aluminum 6063-T6







Welding

Weld spacing is maintained between 2 1/2 inches (63.5 mm) and 4 inches (101.6 mm) on center. Through high quality control testing of welded channels and continuous monitoring of welding equipment, we provide the most consistent combination channels available today.

Metric

Metric dimensions are shown in parentheses. Unless noted, all metric dimensions are in millimeters.

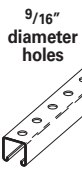
Selection Chart for Channels, Materials and Hole Patterns

Channel Type	Channel Dimensions		Material & Thickness * Stainless Steel				Channel Hole Pattern **				
	Height	Width	Steel	Alum.	Type 304	Type 316	SH	S	H17/8	TH	KO6
			<u>1</u>	<u>2</u>	<u>3</u>	<u>4</u>					
B11	3 1/4" (82.5)	1 5/8" (41.3)	12 Ga.	.105	–	–	<u>1</u>	<u>1</u>	<u>1</u>	–	<u>1</u>
B12	2 7/16" (61.9)	1 5/8" (41.3)	12 Ga.	.105	–	–	<u>1 2</u>	<u>1</u>	<u>1 2</u>	–	<u>1 2</u>
B22	1 5/8" (41.3)	1 5/8" (41.3)	12 Ga.	.105	12 Ga.	12 Ga.	<u>1 2 3 4</u>	<u>1 3</u>	<u>1 2 3 4</u>	<u>1</u>	<u>1 2</u>
B24	1 5/8" (41.3)	1 5/8" (41.3)	14 Ga.	–	14 Ga.	14 Ga.	<u>1 2 3 4</u>	<u>1</u>	<u>1 2 3 4</u>	–	<u>1 2</u>
B32	1 3/8" (34.9)	1 5/8" (41.3)	12 Ga.	–	12 Ga.	–	<u>1 3</u>	<u>1</u>	<u>1 3</u>	–	<u>1</u>
B42	1" (25.4)	1 5/8" (41.3)	12 Ga.	–	12 Ga.	–	<u>1 3</u>	<u>1</u>	<u>1 3</u>	–	<u>1</u>
B52	1 3/16" (20.6)	1 5/8" (41.3)	12 Ga.	–	12 Ga.	12 Ga.	<u>1 3 4</u>	<u>1</u>	<u>1</u>	–	<u>1</u>
B54	1 3/16" (20.6)	1 5/8" (41.3)	14 Ga.	.080	14 Ga.	14 Ga.	<u>1 2 3 4</u>	<u>1</u>	<u>1 2 3 4</u>	–	<u>1 2</u>
B62	1 3/16" (20.6)	1 3/16" (20.6)	18 Ga.	–	–	–	–	–	–	–	–
B72	1 3/32" (10.3)	1 3/16" (20.6)	18 Ga.	–	–	–	–	–	–	–	–

The selection has been prepared to provide a reference for available channel, materials and hole patterns. Material types available for various hole patterns are defined by numbers 1 thru 4.

Some stainless steel channels with hole patterns are available on special order only.

*Metric equivalent for thicknesses shown in chart. ** 1 - Steel
 12 Ga. = 2.6 mm 18 Ga. = 1.2 mm 2 - Aluminum
 14 Ga. = 1.9 mm .105 = 2.6 mm 3 - Type 304 Stainless Steel
 16 Ga. = 1.5 mm .080 = 2.0 mm 4 - Type 316 Stainless Steel

Properties may vary due to commercial tolerances of the material.

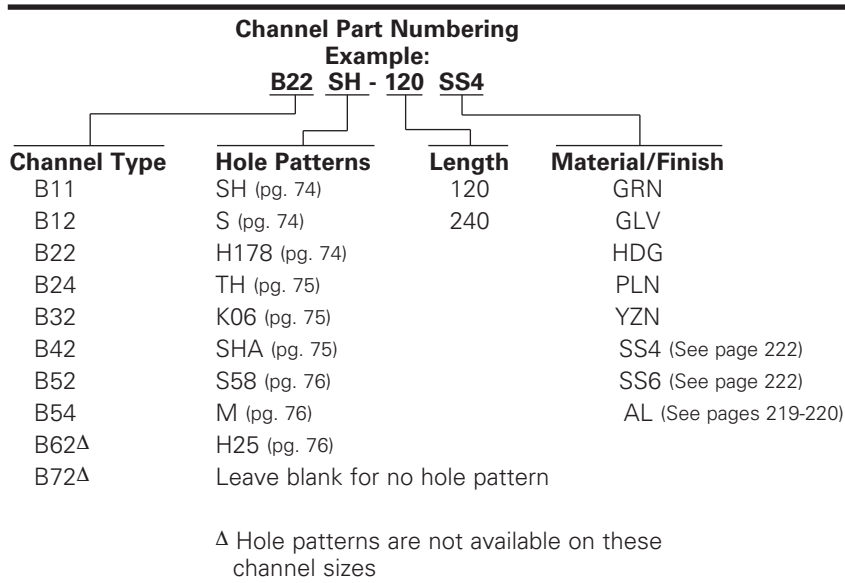

Reference page 48 for general fitting and standard finish specifications.

B11 Channel, Combinations & Load Data

B11

- Thickness: 12 Gauge (2.6 mm)
- Standard lengths: 10' (3.05 m) & 20' (6.09 m)
- Standard finishes: Plain, DURA GREEN™, Pre-Galvanized, Hot-Dipped Galvanized, Aluminum
- Weight: 3.05 Lbs./Ft. (4.54 kg/m)

Note:

Aluminum loading, for B11, can be determined by multiplying load data times a factor of 0.38

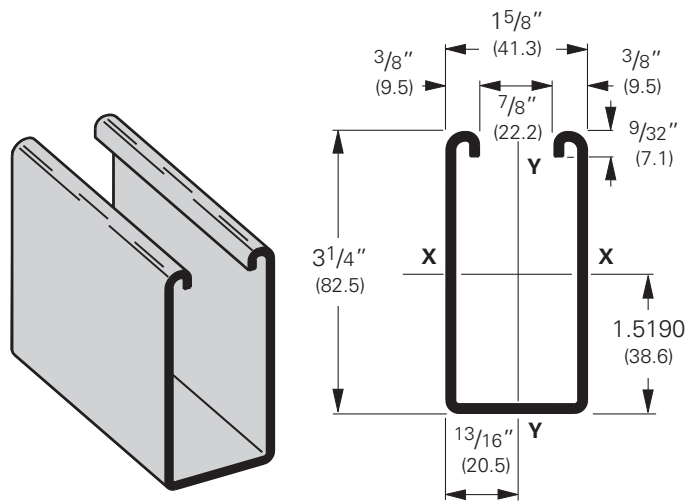

Section Properties			X - X Axis			Y - Y Axis		
Channel	Weight lbs./ft. kg/m	Areas of Section sq. in. cm ²	Moment of Inertia (I) in. ⁴ cm ⁴	Section Modulus (S) in. ³ cm ³	Radius of Gyration (r) in. cm	Moment of Inertia (I) in. ⁴ cm ⁴	Section Modulus (S) in. ³ cm ³	Radius of Gyration (r) in. cm
B11	3.059 (4.55)	.900 (5.81)	1.1203(46.63)	.6472 (10.61)	1.116 (2.83)	.4357 (18.14)	.5362 (8.79)	.696 (1.77)
B11A	6.119 (9.11)	1.800(11.61)	6.3931(266.10)	1.9671 (32.24)	1.885 (4.79)	.8714 (36.27)	1.0725(17.58)	.696 (1.77)

Calculations of section properties are based on metal thicknesses as determined by the AISI Cold-Formed Steel Design Manual.

Beam Loading

Beam Span In. mm	Channel Style	Uniform Load and Deflection				Uniform Load @ Deflection =			
		Lbs. kN		In. mm		1/240 Span		1/360 Span	
		Lbs.	kN	In.	mm	Lbs.	kN	Lbs.	kN
24 (609)	B11	5130	(22.82)	.029	(.73)	5130	(22.82)	5130	(22.82)
	B11A	5130*	(22.82)	.005	(.13)	5130*	(22.82)	5130*	(22.82)
36 (914)	B11	3488	(15.51)	.065	(1.65)	3488	(15.51)	3488	(15.51)
	B11A	5130*	(22.82)	.017	(.43)	5130*	(22.82)	5130*	(22.82)
48 (1219)	B11	2616	(11.63)	.117	(2.97)	2616	(11.63)	2616	(11.63)
	B11A	5130*	(22.82)	.040	(1.01)	5130*	(22.82)	5130*	(22.82)
60 (1524)	B11	2093	(9.31)	.183	(4.65)	2093	(9.31)	1908	(8.49)
	B11A	5130*	(22.82)	.079	(2.00)	5130*	(22.82)	5130*	(22.82)
72 (1829)	B11	1744	(7.76)	.263	(6.68)	1744	(7.76)	1325	(5.89)
	B11A	5130*	(22.82)	.136	(3.45)	5130*	(22.82)	5130*	(22.82)
84 (2133)	B11	1495	(6.65)	.358	(9.09)	1460	(6.49)	974	(4.33)
	B11A	4552	(20.25)	.191	(4.85)	4552	(20.25)	4552	(20.25)
96 (2438)	B11	1308	(5.82)	.468	(11.89)	1118	(4.97)	745	(3.31)
	B11A	3983	(17.72)	.250	(6.35)	3983	(17.72)	3983	(17.72)
108 (2743)	B11	1163	(5.17)	.592	(15.03)	884	(3.93)	589	(2.62)
	B11A	3541	(15.75)	.317	(8.05)	3541	(15.75)	3353	(14.91)
120 (3048)	B11	1046	(4.65)	.731	(18.57)	716	(3.18)	477	(2.12)
	B11A	3187	(14.17)	.391	(9.93)	3187	(14.17)	2716	(12.08)
144 (3657)	B11	872	(3.88)	1.053	(26.74)	497	(2.21)	331	(1.47)
	B11A	2656	(11.81)	.563	(14.30)	2656	(11.81)	1886	(8.39)
168 (4267)	B11	747	(3.32)	1.433	(36.40)	365	(1.62)	243	(1.08)
	B11A	2276	(10.12)	.766	(19.45)	2078	(9.24)	1386	(6.16)
192 (4877)	B11	654	(2.91)	1.871	(47.52)	280	(1.24)	186	(0.83)
	B11A	1992	(8.86)	1.001	(25.42)	1591	(7.08)	1061	(4.72)
216 (5486)	B11	581	(2.58)	2.368	(60.15)	221	(0.98)	147	(0.65)
	B11A	1770	(7.87)	1.267	(32.18)	1257	(5.59)	838	(3.73)
240 (6096)	B11	523	(2.32)	2.924	(74.27)	179	(0.79)	119	(0.53)
	B11A	1593	(7.08)	1.564	(39.72)	1018	(4.53)	679	(3.02)

Based on simple beam condition using an allowable design stress of 25,000 psi (172 MPa) in accordance with MFMA, with adequate lateral bracing (see page 12 for further explanation). Actual yield point of cold rolled steel is 42,000 psi (289 MPa). To determine concentrated load capacity at mid span, multiply uniform load by 0.5 and corresponding deflection by 0.8. *Failure determined by weld shear.

Reference page 48 for general fitting and standard finish specifications.

B11 Beam & Column Loading Data

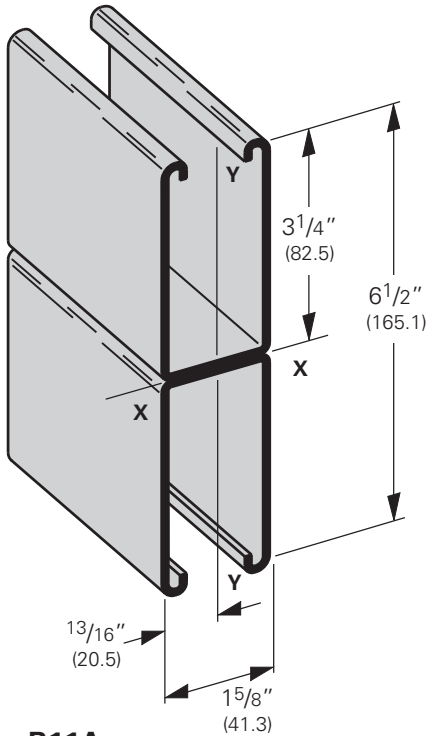

B11A
Wt. 6.10 Lbs./Ft. (9.08 kg/m)

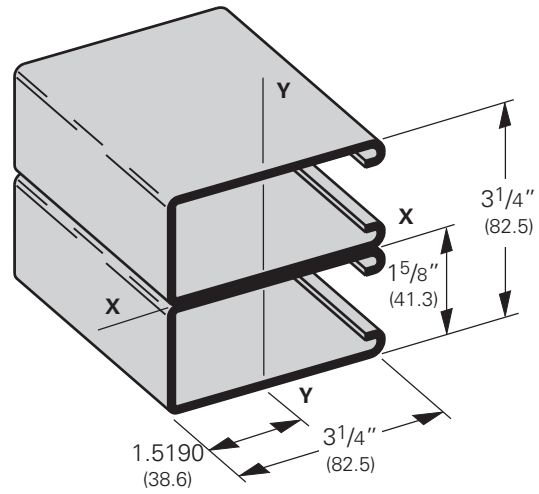

B11B
Wt. 6.10 Lbs./Ft. (9.08 kg/m)

Column Loading

Unbraced Height In. mm	Channel Style	Max. Column Loading K = .80				Max. Column Loading (Loaded @ C.G.)					
		Loaded @ C.G.		Loaded @ Slot Face		K = .65		K = 1.0		K = 1.2	
		Lbs.	kN	Lbs.	kN	Lbs.	kN	Lbs.	kN	Lbs.	kN
24 (609)	B11	8190	(36.43)	4477	(19.91)	8446	(37.57)	7783	(34.62)	7311	(32.52)
	B11A	17701	(78.74)	8267	(36.77)	17778	(79.08)	17572	(78.16)	17416	(77.47)
36 (914)	B11	7311	(32.52)	4183	(18.61)	7838	(34.86)	6503	(28.93)	5612	(24.96)
	B11A	17416	(77.47)	8189	(36.42)	17590	(78.24)	17127	(76.18)	16774	(74.61)
48 (1219)	B11	6214	(27.64)	3783	(16.83)	7053	(31.37)	4988	(22.19)	3816	(16.97)
	B11A	17016	(75.69)	8079	(35.94)	17327	(77.07)	16503	(73.41)	15876	(70.62)
60 (1524)	B11	4988	(22.19)	3279	(14.58)	6140	(27.31)	3595	(15.99)	2790	(12.41)
	B11A	16503	(73.41)	7727	(34.37)	16988	(75.56)	15701	(69.84)	14721	(65.48)
72 (1829)	B11	3816	(16.97)	2444	(10.87)	5146	(22.89)	2790	(12.41)	2213	(9.84)
	B11A	15876	(70.62)	6160	(27.40)	16574	(73.72)	14721	(65.48)	13310	(59.20)
84 (2133)	B11	3063	(13.62)	1897	(8.44)	4133	(18.38)	2291	(10.19)	1846	(8.21)
	B11A	15135	(67.32)	4961	(22.07)	16084	(71.54)	13563	(60.33)	11642	(51.78)
96 (2438)	B11	2564	(11.40)	1532	(6.81)	3398	(15.11)	1953	(8.69)	1591	(7.08)
	B11A	14279	(63.51)	4045	(17.99)	15520	(69.03)	12226	(54.38)	9717	(43.22)
108 (2743)	B11	2213	(9.84)	1273	(5.66)	2886	(12.84)	1708	(7.60)	1401	(6.23)
	B11A	13310	(59.20)	3337	(14.84)	14880	(66.19)	10712	(47.65)	7725	(34.36)
120 (3048)	B11	1953	(8.69)	1081	(4.81)	2514	(11.18)	1522	(6.77)	1251**	(5.56)
	B11A	12226	(54.38)	2784	(12.38)	14164	(63.00)	9019	(40.12)	6257**	(27.83)
144 (3657)	B11	1591	(7.08)	816	(3.63)	2011	(8.94)	1251**	(5.56)	1026**	(4.56)
	B11A	9717	(43.22)	1990	(8.85)	12508	(55.64)	6257**	(27.83)	4345**	(19.33)
168 (4267)	B11	1347	(5.99)	642	(2.85)	1687	(7.50)	1058**	(4.70)	859**	(3.82)
	B11A	7183	(31.95)	1464	(6.51)	10550	(46.93)	4597**	(20.45)	3192**	(14.20)
192 (4877)	B11	1167**	(5.19)	519	(2.31)	1459	(6.49)	910**	(4.05)	-	-
	B11A	5499**	(24.46)	1121	(4.98)	8330	(37.05)	3520**	(15.66)	-	-
216 (5486)	B11	1026**	(4.56)	429	(1.91)	1285**	(5.71)	-	-	-	-
	B11A	4345**	(19.33)	885	(3.93)	6582**	(29.28)	-	-	-	-
240 (6096)	B11	910**	(4.05)	360	(1.60)	1148**	(5.10)	-	-	-	-
	B11A	3520**	(15.66)	717	(3.19)	5331**	(23.71)	-	-	-	-

**Where the slenderness ratio $\frac{KL}{r}$ exceeds 200, and K = end fixity factor, L = actual length and r = radius of gyration.

Reference page 48 for general fitting and standard finish specifications.

B12 Channel, Combinations

B12

- Thickness: 12 Gauge (2.6 mm)
- Standard lengths: 10' (3.05 m) & 20' (6.09 m)
- Standard finishes: Plain, DURA GREEN™, Pre-Galvanized, Hot-Dipped Galvanized, Aluminum
- Weight: 2.47 Lbs./Ft. (3.67 kg/m)

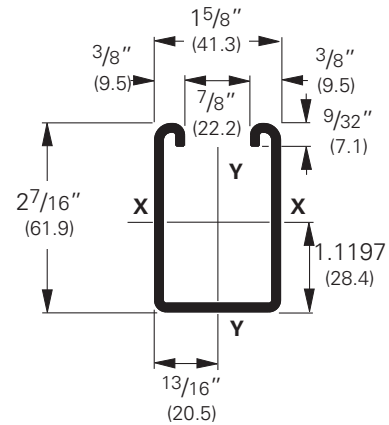
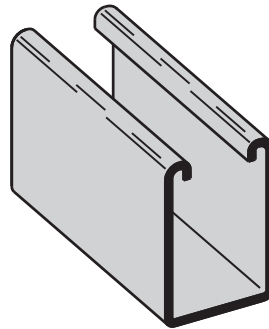

Note:
Aluminum loading, for B12, can be determined by multiplying load data times a factor of 0.38

Section Properties			X - X Axis				Y - Y Axis									
Channel	Weight		Areas of Section	Moment of Inertia (I)		Section Modulus (S)	Radius of Gyration (r)		Moment of Inertia (I)		Section Modulus (S)	Radius of Gyration (r)				
	lbs./ft.	kg/m		sq. in.	cm ²		in. ⁴	cm ⁴	in. ³	cm ³		in. ⁴	cm ⁴	in. ³	cm ³	in.
B12	2.484	(3.70)	.731	(4.71)	.5349	(22.26)	.4061	(6.65)	.856	(2.17)	.3377	(14.06)	.4156	(6.81)	.680	(1.73)
B12A	4.969	(7.40)	1.462	(9.43)	2.9036	(120.86)	1.1915	(19.52)	1.409	(3.58)	.6756	(28.12)	.8315	(13.63)	.680	(1.73)

Calculations of section properties are based on metal thicknesses as determined by the AISI Cold-Formed Steel Design Manual.

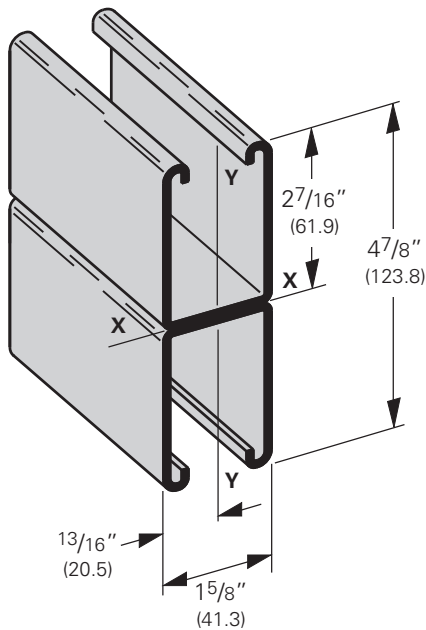

B12A
Wt. 4.94 Lbs./Ft. (7.35 kg/m)

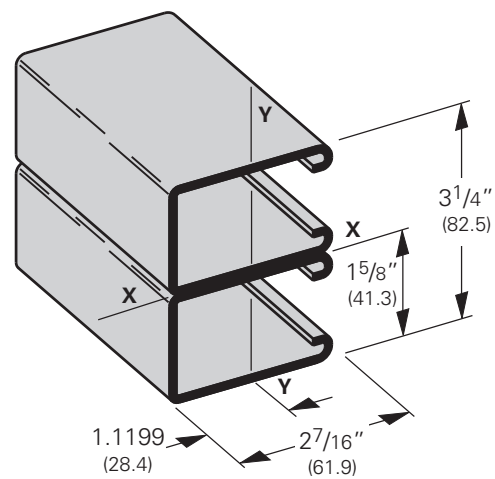

B12B
Wt. 4.94 Lbs./Ft. (7.35 kg/m)

Reference page 48 for general fitting and standard finish specifications.

B12 Beam & Column Loading Data

Beam Loading

Beam Span In. mm	Channel Style	Uniform Load and Deflection				Uniform Load @ Deflection =			
		Lbs.		kN		1/240 Span		1/360 Span	
		In.	mm	Lbs.	kN	Lbs.	kN	Lbs.	kN
12 (305)	B12	3880	(17.26)	.009	(.23)	3880	(17.26)	3880	(17.26)
	B12A	3880*	(17.26)	.001	(.02)	3880*	(17.26)	3880*	(17.26)
24 (609)	B12	3273	(14.56)	.038	(.96)	3273	(14.56)	3273	(14.56)
	B12A	3880*	(17.26)	.008	(.20)	3880*	(17.26)	3880*	(17.26)
36 (914)	B12	2182	(9.70)	.086	(2.18)	2182	(9.70)	2182	(9.70)
	B12A	3880*	(17.26)	.028	(.71)	3880*	(17.26)	3880*	(17.26)
48 (1219)	B12	1636	(7.28)	.153	(3.88)	1636	(7.28)	1421	(6.32)
	B12A	3880*	(17.26)	.067	(1.70)	3880*	(17.26)	3880*	(17.26)
60 (1524)	B12	1309	(5.82)	.240	(6.09)	1309	(5.82)	909	(4.04)
	B12A	3847*	(17.11)	.130	(3.30)	3847*	(17.11)	3847*	(17.11)
72 (1829)	B12	1091	(4.85)	.345	(8.76)	947	(4.21)	632	(2.81)
	B12A	3206	(14.26)	.188	(4.77)	3206	(14.26)	3206	(14.26)
84 (2133)	B12	935	(4.16)	.470	(11.94)	696	(3.09)	464	(2.06)
	B12A	2748	(12.22)	.255	(6.48)	2748	(12.22)	2509	(11.16)
96 (2438)	B12	818	(3.64)	.614	(15.59)	533	(2.37)	355	(1.58)
	B12A	2404	(10.69)	.334	(8.48)	2404	(10.69)	1921	(8.54)
108 (2743)	B12	727	(3.23)	.777	(19.73)	421	(1.87)	281	(1.25)
	B12A	2137	(9.50)	.422	(10.72)	2137	(9.50)	1518	(6.75)
120 (3048)	B12	655	(2.93)	.959	(24.36)	341	(1.52)	227	(1.01)
	B12A	1924	(8.56)	.521	(13.23)	1844	(8.20)	1229	(5.47)

Based on simple beam condition using an allowable design stress of 25,000 psi (172 MPa) in accordance with MFMA, with adequate lateral bracing (see page 12 for further explanation). Actual yield point of cold rolled steel is 42,000 psi. To determine concentrated load capacity at mid span, multiply uniform load by 0.5 and corresponding deflection by 0.8. *Failure determined by weld shear.

Column Loading

Unbraced Height In. mm	Channel Style	Max. Column Loading K = .80				Max. Column Loading (Loaded @ C.G.)					
		Loaded@ C.G.		Loaded@ Slot Face		K = .65		K = 1.0		K = 1.2	
		Lbs.	kN	Lbs.	kN	Lbs.	kN	Lbs.	kN	Lbs.	kN
12 (305)	B12	10140	(45.10)	4752	(21.14)	10247	(45.58)	9965	(44.32)	9756	(43.40)
	B12A	20820	(92.61)	8023	(35.69)	20854	(92.76)	20763	(92.36)	20694	(92.05)
24 (609)	B12	9244	(41.12)	4514	(20.08)	9639	(42.87)	8629	(38.38)	7933	(35.29)
	B12A	20519	(91.27)	7956	(35.39)	20655	(91.88)	20293	(90.27)	20017	(89.04)
36 (914)	B12	7933	(35.29)	4137	(18.40)	8711	(35.75)	6786	(30.18)	5572	(24.78)
	B12A	20017	(89.04)	7844	(34.89)	20324	(90.40)	19509	(86.78)	18889	(84.02)
48 (1219)	B12	6386	(28.40)	3638	(16.18)	7562	(33.64)	4785	(21.28)	3717	(16.53)
	B12A	19315	(85.92)	7688	(34.20)	19861	(88.34)	18412	(81.90)	17309	(76.99)
60 (1524)	B12	4785	(21.28)	2963	(13.18)	6285	(27.96)	3523	(15.67)	2806	(12.48)
	B12A	18412	(81.90)	6941	(30.87)	19265	(85.69)	17002	(75.63)	15278	(67.96)
72 (1829)	B12	3717	(16.53)	2197	(9.77)	4964	(22.08)	2806	(12.48)	2271	(10.10)
	B12A	17309	(76.99)	5334	(23.73)	18536	(82.45)	15278	(67.96)	12795	(56.91)
84 (2133)	B12	3052	(13.57)	1717	(7.64)	3994	(17.76)	2345	(10.43)	1913	(8.51)
	B12A	16005	(71.19)	4176	(18.57)	17675	(78.62)	13240	(58.89)	9884	(43.96)
96 (2438)	B12	2600	(11.56)	1391	(6.19)	3350	(14.90)	2019	(8.98)	1650	(7.34)
	B12A	14500	(64.50)	3328	(14.80)	16682	(74.20)	10889	(48.43)	7567	(33.66)
108 (2743)	B12	2271	(10.10)	1155	(5.14)	2893	(12.87)	1773	(7.88)	1446	(6.43)
	B12A	12795	(56.91)	2692	(11.97)	15556	(69.19)	8610	(38.30)	5979	(26.59)
120 (3048)	B12	2019	(8.98)	977	(4.34)	2553	(11.35)	1577	(7.01)	1279**	(5.69)
	B12A	10889	(48.43)	2202	(9.79)	14298	(63.60)	6974	(31.02)	4843**	(21.54)

**Where the slenderness ratio $\frac{L}{r}$ exceeds 200, and K = end fixity factor, L = actual length and r = radius of gyration.

Reference page 48 for general fitting and standard finish specifications.

B22 Channel

B22

- Thickness: 12 Gauge (2.6 mm)
- Standard lengths: 10' (3.05 m) & 20' (6.09 m)
- Standard finishes: Plain, DURA GREEN™, Pre-Galvanized, Hot-Dipped Galvanized, Stainless Steel Type 304 or 316, Aluminum
- Weight: 1.90 Lbs./Ft. (2.83 kg/m)

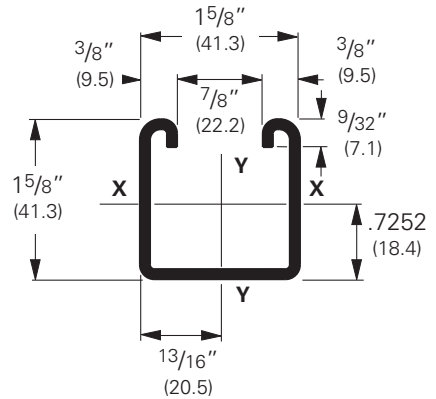
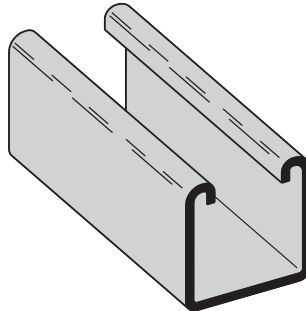

Note:

Aluminum loading, for B22 & B22A, can be determined by multiplying load data times a factor of 0.38

Section Properties			X - X Axis				Y - Y Axis									
Channel	Weight		Areas of Section	Moment of Inertia (I)		Section Modulus (S)	Radius of Gyration (r)	Moment of Inertia (I)		Section Modulus (S)	Radius of Gyration (r)					
	lbs./ft.	kg/m		sq. in.	cm ²			in. ⁴	cm ⁴			in. ⁴	cm ⁴	in. ³	cm ³	in.
B22	1.910	(2.84)	.562	(3.62)	.1912	(7.96)	.2125	(3.48)	.583	(1.48)	.2399	(9.99)	.2953	(4.84)	.653	(1.66)
B22A	3.820	(5.69)	1.124	(7.25)	.9732	(40.51)	.5989	(9.81)	.931	(2.36)	.4798	(19.97)	.5905	(9.68)	.653	(1.66)
B22X	6.649	(9.89)	1.956	(12.62)	4.1484	(172.67)	1.7019	(27.89)	1.456	(3.70)	1.1023	(45.88)	1.2027	(19.71)	.751	(1.91)

Calculations of section properties are based on metal thicknesses as determined by the AISI Cold-Formed Steel Design Manual.

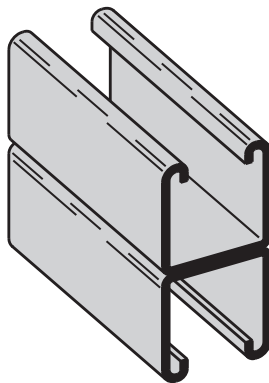

B22A

Wt. 3.80 Lbs./Ft. (5.65 kg/m)

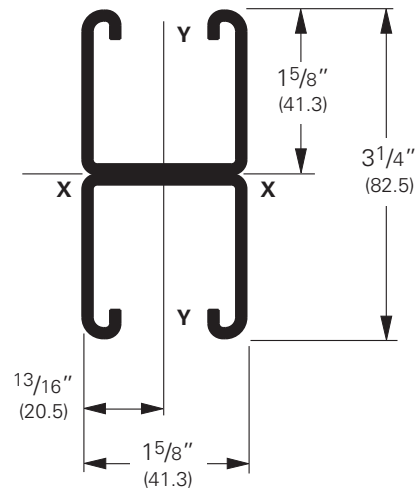

B22 Combinations

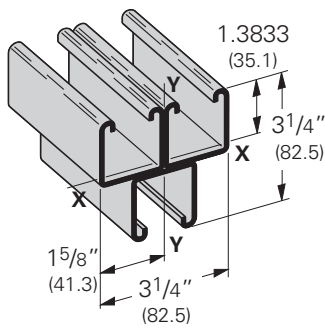

B22A3

Wt. 5.70 Lbs./Ft. (8.48 kg/m)

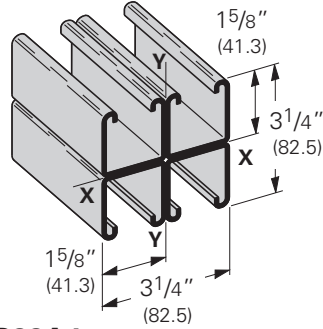

B22A4

Wt. 7.60 Lbs./Ft. (11.31 kg/m)

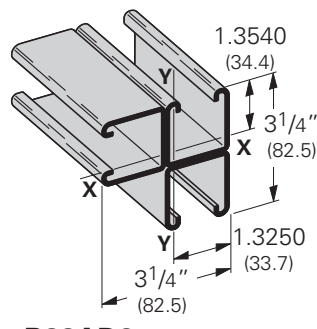

B22AD3

Wt. 5.70 Lbs./Ft. (8.48 kg/m)

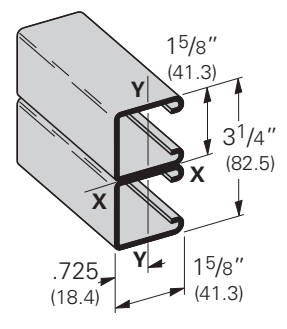

B22B

Wt. 3.80 Lbs./Ft. (5.65 kg/m)

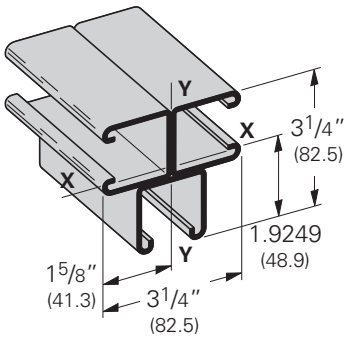

B22B3

Wt. 5.70 Lbs./Ft. (8.48 kg/m)

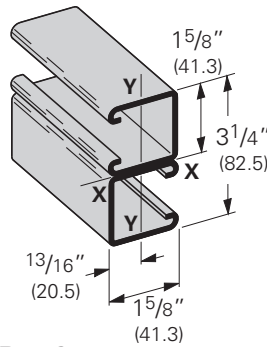

B22C

Wt. 3.80 Lbs./Ft. (5.65 kg/m)

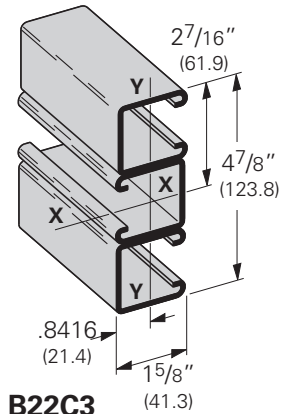

B22C3

Wt. 5.70 Lbs./Ft. (8.48 kg/m)

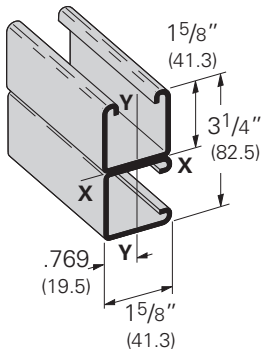

B22D

Wt. 3.80 Lbs./Ft. (5.65 kg/m)

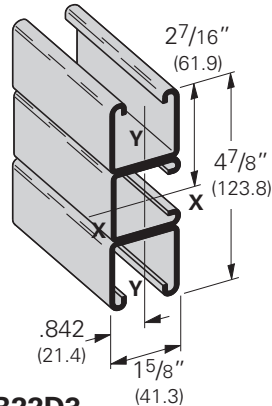

B22D3

Wt. 5.70 Lbs./Ft. (8.48 kg/m)

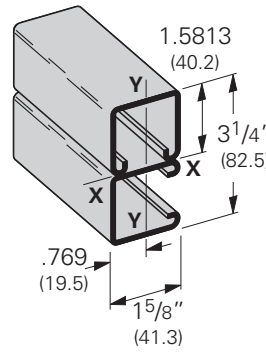

B22E

Wt. 3.80 Lbs./Ft. (5.65 kg/m)

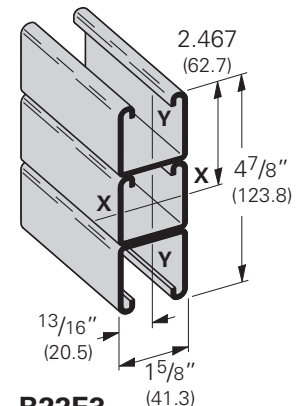

B22E3

Wt. 5.70 Lbs./Ft. (8.48 kg/m)

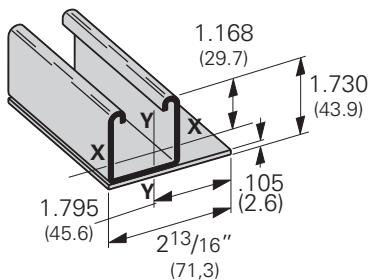

B22LPL

Wt. 2.90 Lbs./Ft. (4.31 kg/m)

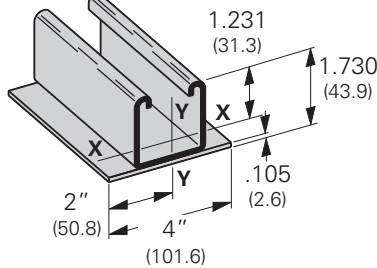

B22PL

Wt. 3.35 Lbs./Ft. (4.98 kg/m)

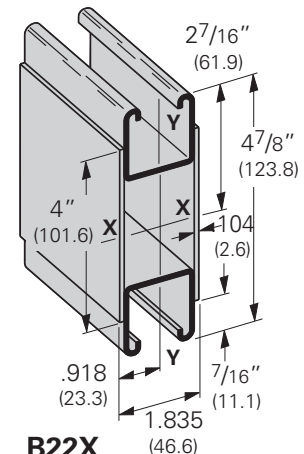

B22X

Wt. 6.70 Lbs./Ft. (9.97 kg/m)

Reference page 48 for general fitting and standard finish specifications.

B22 Beam Loading Data

Beam Loading

Beam Span In. mm		Channel Style	Uniform Load and Deflection				Uniform Load @ Deflection =			
			Lbs.		kN		1/240 Span		1/360 Span	
			Lbs.	kN	In.	mm	Lbs.	kN	Lbs.	kN
12	(305)	B22	2610	(11.61)	.014	(.35)	2610	(11.61)	2610	(11.61)
		B22A	2610*	(11.61)	.002	(.05)	2610*	(11.61)	2610*	(11.61)
		B22X	5790*	(25.75)	.001	(.02)	5790*	(25.75)	5790*	(25.75)
18	(457)	B22	2269	(10.09)	.031	(.79)	2269	(10.09)	2269	(10.09)
		B22A	2610*	(11.61)	.007	(.18)	2610*	(11.61)	2610*	(11.61)
		B22X	5790*	(25.75)	.003	(.07)	5790*	(25.75)	5790*	(25.75)
24	(609)	B22	1702	(7.57)	.056	(1.42)	1702	(7.57)	1702	(7.57)
		B22A	2610*	(11.61)	.017	(.43)	2610*	(11.61)	2610*	(11.61)
		B22X	5790*	(25.75)	.008	(.20)	5790*	(25.75)	5790*	(25.75)
30	(762)	B22	1361	(6.05)	.087	(2.21)	1361	(6.05)	1294	(5.75)
		B22A	2610*	(11.61)	.033	(.84)	2610*	(11.61)	2610*	(11.61)
		B22X	5790*	(25.75)	.017	(.73)	5790*	(25.75)	5790*	(25.75)
36	(914)	B22	1135	(5.05)	.126	(3.20)	1135	(5.05)	899	(4.00)
		B22A	2610*	(11.61)	.057	(1.45)	2610*	(11.61)	2610*	(11.61)
		B22X	5790*	(25.75)	.029	(.73)	5790*	(25.75)	5790*	(25.75)
42	(1067)	B22	972	(4.32)	.172	(4.37)	972	(4.32)	660	(2.93)
		B22A	2610*	(11.61)	.091	(2.31)	2610*	(11.61)	2610*	(11.61)
		B22X	5790*	(25.75)	.046	(1.17)	5790*	(25.75)	5790*	(25.75)
48	(1219)	B22	851	(3.78)	.224	(5.69)	758	(3.37)	505	(2.24)
		B22A	2405	(10.70)	.125	(3.17)	2405	(10.70)	2405	(10.70)
		B22X	5790*	(25.75)	.068	(1.73)	5790*	(25.75)	5790*	(25.75)
54	(1371)	B22	756	(3.36)	.284	(7.21)	599	(2.66)	399	(1.77)
		B22A	2138	(9.51)	.158	(4.01)	2138	(9.51)	2024	(9.00)
		B22X	5790*	(25.75)	.097	(2.46)	5790*	(25.75)	5790*	(25.75)
60	(1524)	B22	681	(3.03)	.351	(8.91)	485	(2.16)	323	(1.44)
		B22A	1924	(8.56)	.195	(4.95)	1924	(8.56)	1640	(7.29)
		B22X	5645	(25.11)	.130	(3.30)	5645	(25.11)	5645	(25.11)
66	(1676)	B22	619	(2.75)	.424	(10.77)	401	(1.78)	267	(1.19)
		B22A	1749	(7.78)	.236	(5.99)	1749	(7.78)	1355	(6.03)
		B22X	5132	(22.83)	.158	(4.01)	5132	(22.83)	5132	(22.83)
72	(1829)	B22	567	(2.52)	.505	(12.83)	337	(1.50)	225	(1.00)
		B22A	1603	(7.13)	.281	(7.14)	1603	(7.13)	1139	(5.06)
		B22X	4704	(20.92)	.188	(4.77)	4704	(20.92)	4704	(20.92)
78	(1981)	B22	524	(2.33)	.593	(15.06)	287	(1.27)	191	(0.85)
		B22A	1480	(6.58)	.330	(8.38)	1455	(6.47)	970	(4.31)
		B22X	4342	(19.31)	.220	(5.59)	4342	(19.31)	4270	(18.99)
84	(2133)	B22	486	(2.16)	.687	(17.45)	248	(1.10)	165	(0.73)
		B22A	1374	(6.11)	.383	(9.73)	1255	(5.58)	837	(3.72)
		B22X	4032	(17.93)	.255	(6.48)	4032	(17.93)	3682	(16.38)
90	(2286)	B22	454	(2.02)	.789	(20.04)	216	(0.96)	144	(0.64)
		B22A	1283	(5.71)	.440	(11.17)	1093	(4.86)	729	(3.24)
		B22X	3763	(16.74)	.293	(7.44)	3763	(16.74)	3207	(14.26)
96	(2438)	B22	425	(1.89)	.898	(22.81)	190	(0.84)	126	(0.56)
		B22A	1202	(5.35)	.500	(12.70)	961	(4.27)	640	(2.85)
		B22X	3528	(15.69)	.334	(8.48)	3528	(15.69)	2819	(12.54)
102	(2591)	B22	400	(1.78)	1.013	(25.73)	168	(0.75)	112	(0.50)
		B22A	1132	(5.03)	.565	(14.35)	851	(3.78)	567	(2.52)
		B22X	3320	(14.77)	.377	(9.57)	3320	(14.77)	2497	(11.11)
108	(2743)	B22	378	(1.68)	1.136	(28.85)	150	(0.67)	100	(0.44)
		B22A	1069	(4.75)	.633	(16.08)	759	(3.37)	506	(2.25)
		B22X	3136	(13.95)	.422	(10.72)	3136	(13.95)	2227	(9.90)
114	(2895)	B22	358	(1.59)	1.266	(32.15)	134	(0.59)	90	(0.40)
		B22A	1013	(4.50)	.706	(17.93)	681	(3.03)	454	(2.02)
		B22X	2971	(13.21)	.471	(11.96)	2971	(13.21)	1999	(8.89)
120	(3048)	B22	340	(1.51)	1.403	(35.63)	121	(0.54)	81	(0.36)
		B22A	962	(4.28)	.782	(19.86)	615	(2.73)	410	(1.82)
		B22X	2822	(12.55)	.521	(13.23)	2706	(12.04)	1804	(8.02)

Based on simple beam condition using an allowable design stress of 25,000 psi (172 MPa) in accordance with MFMA, with adequate lateral bracing (see page 12 for further explanation). Actual yield point of cold rolled steel is 42,000 psi. To determine concentrated load capacity at mid span, multiply uniform load by 0.5 and corresponding deflection by 0.8. *Failure determined by weld shear.

Reference page 48 for general fitting and standard finish specifications.

B24 Channel & Combinations

B24

- Thickness: 14 Gauge (1.9 mm)
- Standard lengths: 10' (3.05 m) & 20' (6.09 m)
- Standard finishes: Plain, DURA GREEN™, Pre-Galvanized, Hot-Dipped Galvanized, Stainless Steel Type 304 or 316
- Weight: 1.40 Lbs./Ft. (2.08 kg/m)

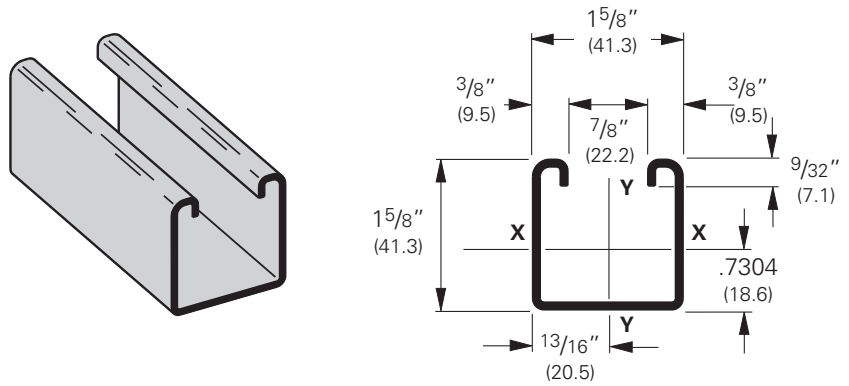

Section Properties			X - X Axis			Y - Y Axis										
Channel	Weight		Areas of Section	Moment of Inertia (I)	Section Modulus (S)	Radius of Gyration (r)	Moment of Inertia (I)	Section Modulus (S)	Radius of Gyration (r)							
	lbs./ft.	kg/m								sq. in.	cm ²	in. ⁴	cm ⁴	in. ³	cm ³	in.
B24	1.442	(2.15)	.424	(2.74)	.1494	(6.22)	.1670	(2.74)	.594	(1.51)	.1857	(7.73)	.2286	(3.75)	.662	(1.68)
B24A	2.884	(4.29)	.848	(5.47)	.7514	(31.28)	.4624	(7.58)	.941	(2.39)	.3713	(15.45)	.4570	(7.49)	.662	(1.68)

Calculations of section properties are based on metal thicknesses as determined by the AISI Cold-Formed Steel Design Manual.

Channel & Combinations

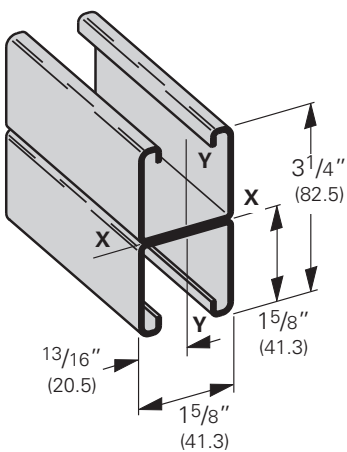

B24A
Wt. 2.80 Lbs./Ft. (4.16 kg/m)

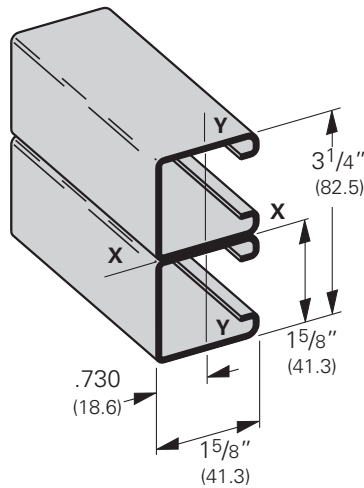

B24B
Wt. 2.80 Lbs./Ft. (4.16 kg/m)

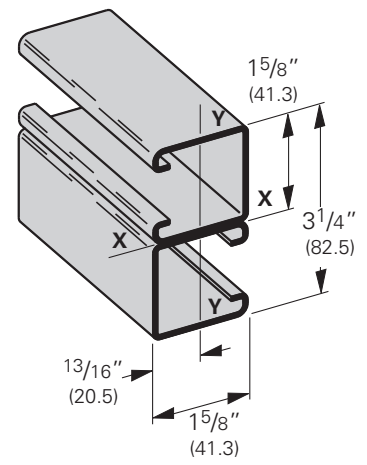

B24C
Wt. 2.80 Lbs./Ft. (4.16 kg/m)

Reference page 48 for general fitting and standard finish specifications.

B24 Beam & Column Loading Data

Beam Loading

Beam Span In. mm	Channel Style	Uniform Load and Deflection				Uniform Load @ Deflection =			
		Lbs. kN		In. mm		1/240 Span		1/360 Span	
		Lbs.	kN	In.	mm	Lbs.	kN	Lbs.	kN
12 (305)	B24	1750	(7.78)	.014	(.35)	1750	(7.78)	1750	(7.78)
	B24A	1750*	(7.78)	.002	(.05)	1750*	(7.78)	1750*	(7.78)
24 (609)	B24	1379	(6.13)	.057	(1.45)	1379	(6.13)	1379	(6.13)
	B24A	1750*	(7.78)	.014	(.35)	1750*	(7.78)	1750*	(7.78)
36 (914)	B24	919	(4.09)	.128	(3.25)	919	(4.09)	720	(3.20)
	B24A	1750*	(7.78)	.048	(1.22)	1750*	(7.78)	1750*	(7.78)
48 (1219)	B24	689	(3.06)	.227	(5.76)	607	(2.70)	405	(1.80)
	B24A	1750*	(7.78)	.115	(2.92)	1750*	(7.78)	1750*	(7.78)
60 (1524)	B24	551	(2.45)	.355	(9.02)	389	(1.73)	259	(1.15)
	B24A	1518	(6.75)	.195	(4.95)	1518	(6.75)	1294	(5.75)
72 (1829)	B24	460	(2.04)	.511	(12.98)	270	(1.20)	180	(0.80)
	B24A	1265	(5.63)	.281	(7.14)	1265	(5.63)	898	(3.99)
84 (2133)	B24	394	(1.75)	.695	(17.65)	198	(0.88)	132	(0.59)
	B24A	1084	(4.82)	.383	(9.73)	990	(4.40)	660	(2.93)
96 (2438)	B24	345	(1.53)	.908	(23.06)	152	(0.67)	101	(0.45)
	B24A	949	(4.22)	.500	(12.70)	758	(3.37)	505	(2.24)
108 (2743)	B24	306	(1.36)	1.149	(29.18)	120	(0.53)	80	(0.35)
	B24A	843	(3.75)	.633	(16.08)	599	(2.66)	399	(1.77)
120 (3048)	B24	276	(1.23)	1.419	(36.04)	97	(0.43)	65	(0.29)
	B24A	759	(3.37)	.782	(19.86)	485	(2.16)	323	(1.44)

Based on simple beam condition using an allowable design stress of 25,000 psi (172 MPa) in accordance with MFMA, with adequate lateral bracing (see page 12 for further explanation). Actual yield point of cold rolled steel is 42,000 psi. To determine concentrated load capacity at mid span, multiply uniform load by 0.5 and corresponding deflection by 0.8. *Failure determined by weld shear.

Column Loading

Unbraced Height In. mm	Channel Style	Max. Column Loading K = .80				Max. Column Loading (Loaded @ C.G.)					
		Loaded@ C.G.		Loaded@ Slot Face		K = .65		K = 1.0		K = 1.2	
		Lbs.	kN	Lbs.	kN	Lbs.	kN	Lbs.	kN	Lbs.	kN
12 (305)	B24	6441	(28.65)	3077	(13.69)	6509	(28.95)	6330	(28.16)	6198	(27.57)
	B24A	13212	(58.77)	4988	(22.19)	13237	(58.88)	13171	(58.59)	13121	(58.36)
24 (609)	B24	5874	(26.13)	2896	(12.88)	6124	(27.24)	5483	(24.39)	5038	(22.41)
	B24A	12993	(57.79)	4924	(21.90)	13092	(58.23)	12828	(57.06)	12627	(56.17)
36 (914)	B24	5038	(22.41)	2619	(11.65)	5535	(24.62)	4302	(19.13)	3516	(15.64)
	B24A	12627	(56.17)	4819	(21.43)	12851	(57.16)	12256	(54.52)	11804	(52.51)
48 (1219)	B24	4043	(17.98)	2272	(10.10)	4800	(21.35)	3008	(13.38)	2324	(10.34)
	B24A	12115	(53.89)	4675	(20.79)	12512	(55.65)	11456	(50.96)	10651	(47.38)
60 (1524)	B24	3008	(13.38)	1873	(8.33)	3978	(17.69)	2200	(9.78)	1740	(7.74)
	B24A	11456	(50.96)	4020	(17.88)	12078	(53.72)	10427	(46.38)	9169	(40.78)
72 (1829)	B24	2324	(10.34)	1562	(6.95)	3123	(13.89)	1740	(7.74)	1397	(6.21)
	B24A	10651	(47.38)	3048	(13.56)	11546	(51.36)	9169	(40.78)	7358	(32.73)
84 (2133)	B24	1898	(8.44)	1340	(5.96)	2502	(11.13)	1444	(6.42)	1168	(5.19)
	B24A	9700	(43.15)	2362	(10.50)	10918	(48.56)	7683	(34.17)	5464	(24.30)
96 (2438)	B24	1608	(7.15)	1175	(5.22)	2089	(9.29)	1236	(5.50)	1000	(4.45)
	B24A	8602	(38.26)	1866	(8.30)	10194	(45.34)	6024	(26.79)	4184	(18.61)
108 (2743)	B24	1397	(6.21)	1046	(4.65)	1796	(7.99)	1078	(4.79)	870**	(3.87)
	B24A	7358	(32.73)	1498	(6.66)	9373	(41.69)	4760	(21.17)	3306	(14.70)
120 (3048)	B24	1236	(5.50)	942	(4.19)	1578	(7.02)	953**	(4.24)	764**	(3.40)
	B24A	6024	(26.79)	1216	(5.41)	8455	(37.61)	3856	(17.15)	2677**	(11.91)

**Where the slenderness ratio $\frac{KL}{r}$ exceeds 200, and K = end fixity factor, L = actual length and r = radius of gyration.

Reference page 48 for general fitting and standard finish specifications.

B26 Channel & Combinations

B26

- Thickness: 16 Gauge (1.5 mm)
- Standard lengths: 10' (3.05 m) & 20' (6.09 m)
- Standard finishes: Plain, DURA GREEN™, Pre-Galvanized
- Weight: 1.12 Lbs./Ft. (1.66 kg/m)

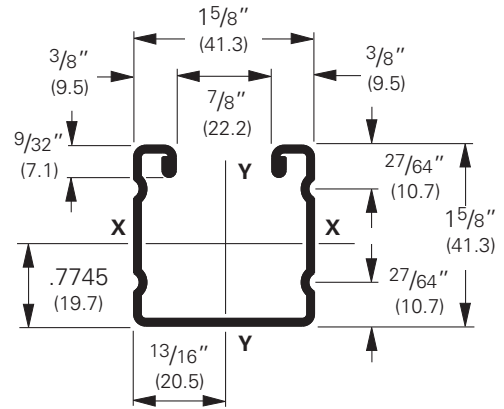
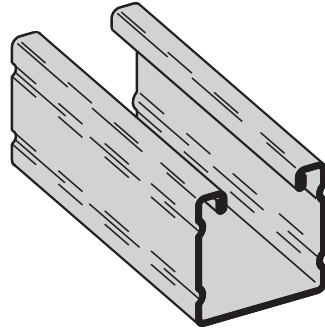

Section Properties

Channel	Weight lbs./ft. kg/m	Areas of Section sq. in. cm ²	X - X Axis			Y - Y Axis		
			Moment of Inertia (I) in. ⁴ cm ⁴	Section Modulus (S) in. ³ cm ³	Radius of Gyration (r) in. cm	Moment of Inertia (I) in. ⁴ cm ⁴	Section Modulus (S) in. ³ cm ³	Radius of Gyration (r) in. cm
B26	1.234 (1.84)	.363 (2.34)	.1337 (5.57)	.1581 (2.59)	.607 (1.54)	.1337 (5.57)	.1925 (3.15)	.656 (1.67)
B26A	2.467 (3.67)	.726 (4.68)	.7086 (29.49)	.4361 (7.15)	.988 (25.1)	.7086 (29.49)	.3850 (6.31)	.656 (1.67)

Calculations of section properties are based on metal thicknesses as determined by the AISI Cold-Formed Steel Design Manual.

Channel & Combinations

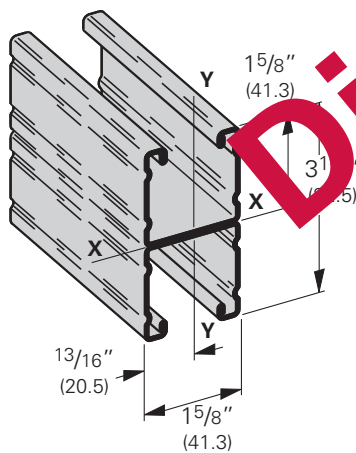

B26A

Wt. 2.24 Lbs./Ft. (3.33 kg/m)

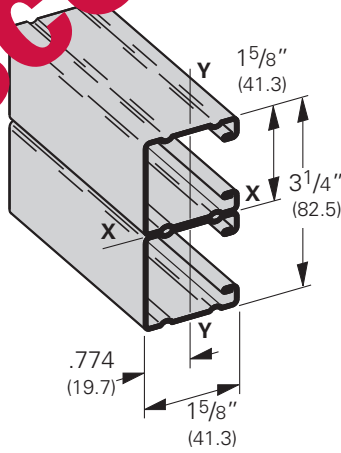

B26B

Wt. 2.24 Lbs./Ft. (3.33 kg/m)

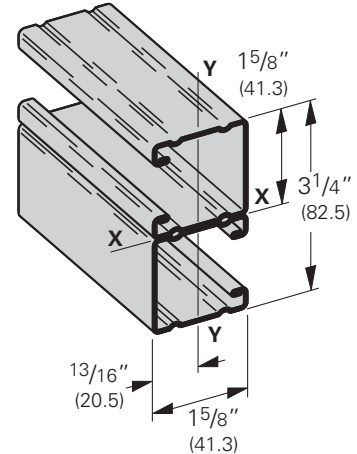

B26C

Wt. 2.24 Lbs./Ft. (3.33 kg/m)

Reference page 48 for general fitting and standard finish specifications.

B26 Beam & Column Loading Data

Beam Loading

Beam Span In. mm	Channel Style	Uniform Load and Deflection				Uniform Load @ Deflection =			
		Lbs. kN		In. mm		1/240 Span Lbs. kN		1/360 Span Lbs. kN	
12 (305)	B26	1220 (5.43)		.014 (.35)		1220 (5.43)		1220 (5.43)	
	B26A	1220* (5.43)		.001 (.02)		1220* (5.43)		1220* (5.43)	
24 (609)	B26	1163 (5.17)		.057 (1.45)		1163 (5.17)		1163 (5.17)	
	B26A	1220* (5.43)		.012 (.30)		1220* (5.43)		1220* (5.43)	
36 (914)	B26	775 (3.45)		.128 (3.25)		775 (3.45)		603 (2.68)	
	B26A	1220* (5.43)		.040 (1.01)		1220* (5.43)		1220* (5.43)	
48 (1219)	B26	581 (2.58)		.228 (5.79)		509 (2,264)		339 (1.51)	
	B26A	1220* (5.43)		.096 (2.44)		1220* (5.43)		1220* (5.43)	
60 (1524)	B26	465 (2.07)		.357 (9.07)		326 (1,45)		217 (0.96)	
	B26A	1220* (5.43)		.188 (4.77)		1220* (5.43)		1076 (4.78)	
72 (1829)	B26	388 (1.72)		.514 (13.05)		226 (1,45)		151 (0.96)	
	B26A	1052 (4.68)		.281 (7.14)		1052 (4,68)		747 (3.32)	
84 (2133)	B26	332 (1.48)		.699 (17.75)		166 (0.74)		111 (0.49)	
	B26A	902 (4.01)		.383 (9.73)		824 (3.66)		549 (2.44)	
96 (2438)	B26	291 (1.29)		.913 (23.19)		127 (0.56)		85 (0.38)	
	B26A	789 (3.51)		.500 (12.70)		631 (2.81)		420 (1.87)	
108 (2743)	B26	258 (1.15)		1.156 (29.36)		101 (0.45)		67 (0.30)	
	B26A	702 (3.12)		.633 (16.08)		498 (2.21)		332 (1.48)	
120 (3048)	B26	233 (1.03)		1.427 (36.24)		81 (0.36)		54 (0.24)	
	B26A	631 (2.17)		.782 (19.86)		570 (2.55)		269 (1.19)	

Based on simple beam condition using an allowable design stress of 25,000 psi (172 MPa) in accordance with MFMA, with adequate lateral bracing (see page 12 for further explanation). Actual yield point of cold rolled steel is 42,000 psi. To determine concentrated load capacity at mid span, multiply uniform load by 0.5 and corresponding deflection by 0.8. *Failure determined by weld shear.

Column Loading

Unbraced Height In. mm	Channel Style	Max. Column Loading K = 1.0				Max. Column Loading (Loaded @ C.G.)					
		Loaded@ C.G.		Loaded@ Slab Face		K = .65		K = 1.0		K = 1.2	
		Lbs.	kN	Lbs.	kN	Lbs.	kN	Lbs.	kN	Lbs.	kN
12 (305)	B26	4002 (17.80)		2236 (9.86)		4032 (17.93)		3952 (17.58)		3891 (17.31)	
	B26A	8151 (36.2)		3600 (16.15)		8163 (36.31)		8133 (36.18)		8109 (36.07)	
24 (609)	B26	3740 (16.73)		2109 (9.38)		3857 (17.16)		3554 (15.81)		3336 (14.84)	
	B26A	8057 (35.8)		3591 (15.97)		8096 (36.01)		7975 (35.47)		7883 (35.06)	
36 (914)	B26	2736 (12.19)		1941 (8.63)		3579 (15.92)		2962 (13.17)		2546 (11.32)	
	B26A	7883 (35.06)		3528 (15.69)		7986 (35.52)		7713 (34.31)		7505 (33.38)	
48 (1219)	B26	2828 (12.58)		1725 (7.61)		3217 (14.31)		2251 (10.01)		1705 (7.58)	
	B26A	648 (2.88)		3441 (15.30)		7831 (34.83)		7346 (32.67)		6977 (31.03)	
60 (1524)	B26	2251 (10.01)		1469 (6.53)		2793 (12.42)		1603 (7.13)		1233 (5.48)	
	B26A	7346 (32.67)		3066 (13.64)		7631 (33.94)		6874 (30.58)		6298 (28.01)	
72 (1829)	B26	1705 (7.58)		1203 (5.35)		2326 (10.34)		1233 (5.48)		967 (4.30)	
	B26A	6977 (31.03)		2385 (10.61)		7388 (32.86)		6298 (28.01)		5467 (24.32)	
84 (2133)	B26	1358 (6.04)		1011 (4.50)		1851 (8.23)		1003 (4.46)		797 (3.54)	
	B26A	6541 (29.09)		1884 (8.38)		7100 (31.58)		5616 (24.98)		4486 (19.95)	
96 (2438)	B26	1129 (5.02)		871 (3.87)		1513 (6.73)		847 (3.77)		680 (3.02)	
	B26A	6038 (26.86)		1512 (6.72)		6767 (30.10)		4830 (21.48)		3463 (15.40)	
108 (2743)	B26	967 (4.30)		766 (3.41)		1277 (5.68)		734 (3.26)		592** (2.63)	
	B26A	5467 (24.32)		1231 (5.47)		6391 (28.43)		3940 (17.52)		2736 (12.17)	
120 (3048)	B26	847 (3.77)		684 (3.04)		1105 (4.91)		648 (2.88)		523** (2.32)	
	B26A	4830 (21.48)		1015 (4.51)		5970 (26.55)		3192 (14.20)		2216** (9.86)	

**Where the slenderness ratio $\frac{KL}{r}$ exceeds 200, and K = end fixity factor, L = actual length and r = radius of gyration.

Reference page 48 for general fitting and standard finish specifications.

B32 Channel & Combinations

B32

- Thickness: 12 Gauge (2.6 mm)
- Standard lengths: 10' (3.05 m) & 20' (6.09 m)
- Standard finishes: Plain, DURA GREEN™, Pre-Galvanized, Hot-Dipped Galvanized, Stainless Steel Type 304
- Weight: 1.70 Lbs./Ft. (2.53 kg/m)

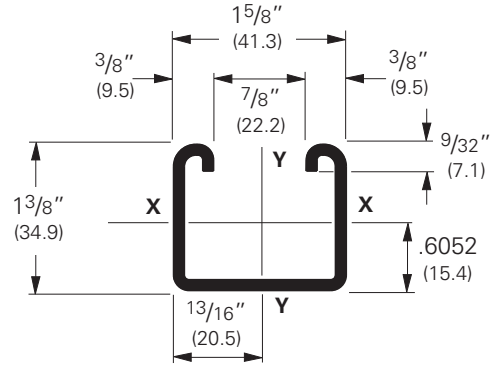
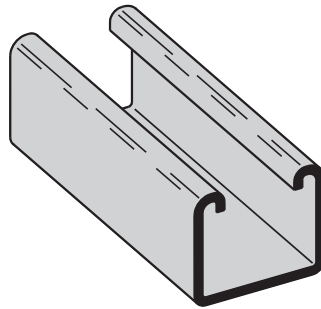

Section Properties			X - X Axis				Y - Y Axis									
Channel	Weight		Areas of Section	Moment of Inertia (I)		Section Modulus (S)	Radius of Gyration (r)	Moment of Inertia (I)		Section Modulus (S)	Radius of Gyration (r)					
	lbs./ft.	kg/m		sq. in.	cm ²			in. ⁴	cm ⁴			in. ⁴	cm ⁴	in. ³	cm ³	in.
B32	1.733	(2.58)	.510	(3.29)	.1252	(5.21)	.1626	(2.67)	.496	(1.26)	.2098	(8.73)	.2582	(4.23)	.642	(1.63)
B32A	3.467	(5.16)	1.020	(6.58)	.6238	(25.96)	.4537	(7.43)	.782	(1.99)	.4195	(17.46)	.5163	(8.46)	.642	(1.63)

Calculations of section properties are based on metal thicknesses as determined by the AISI Cold-Formed Steel Design Manual.

Channel & Combinations

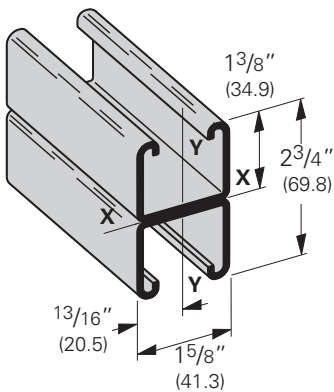

B32A
Wt. 3.40 Lbs./Ft. (5.06 kg/m)

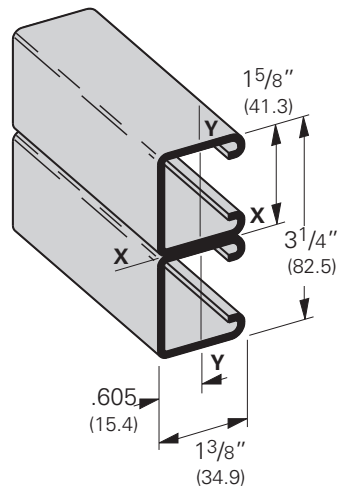

B32B
Wt. 3.40 Lbs./Ft. (5.06 kg/m)

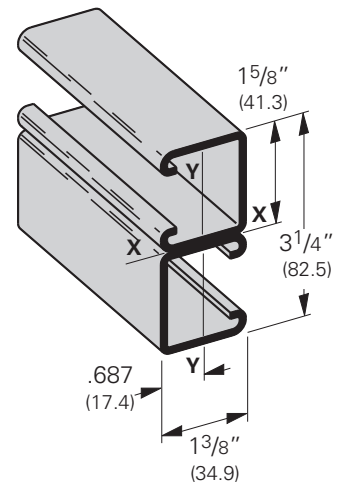

B32C
Wt. 3.40 Lbs./Ft. (5.06 kg/m)

Reference page 48 for general fitting and standard finish specifications.

B32 Beam & Column Loading Data

Beam Loading

Beam Span In. mm		Channel Style	Uniform Load and Deflection				Uniform Load @ Deflection =			
			1/240 Span		1/360 Span					
			Lbs.	kN	In.	mm	Lbs.	kN	Lbs.	kN
12	(305)	B32	2210	(9.83)	.016	(.40)	2210	(9.83)	2210	(9.83)
		B32A	2210*	(9.83)	.003	(.07)	2210*	(9.83)	2210*	(9.83)
24	(609)	B32	1299	(5.78)	.065	(1.65)	1299	(5.78)	1299	(5.78)
		B32A	2210*	(9.83)	.022	(.56)	2210*	(9.83)	2210*	(9.83)
36	(914)	B32	866	(3.85)	.147	(3.73)	866	(3.85)	587	(2.61)
		B32A	2210*	(9.83)	.076	(1.93)	2210*	(9.83)	2210*	(9.83)
48	(1219)	B32	649	(2.89)	.262	(6.65)	495	(2.20)	330	(1.47)
		B32A	1817	(8.08)	.148	(3.76)	1817	(8.08)	1638	(7.28)
60	(1524)	B32	520	(2.31)	.410	(10.41)	317	(1.41)	211	(0.94)
		B32A	1454	(6.47)	.231	(5.87)	1454	(6.47)	1048	(4.66)
72	(1829)	B32	433	(1.92)	.590	(14.98)	220	(0.98)	147	(0.65)
		B32A	1211	(5.39)	.333	(8.46)	1092	(4.86)	728	(3.24)
84	(2133)	B32	371	(1.65)	.803	(20.39)	162	(0.72)	108	(0.48)
		B32A	1038	(4.62)	.453	(11.50)	802	(3.57)	535	(2.38)
96	(2438)	B32	325	(1.44)	1.049	(26.64)	124	(0.55)	83	(0.37)
		B32A	909	(4.04)	.591	(15.01)	614	(2.73)	410	(1.82)
108	(2743)	B32	289	(1.28)	1.327	(33.70)	98	(0.43)	65	(0.29)
		B32A	808	(3.59)	.749	(19.02)	485	(2.16)	324	(1.44)
120	(3048)	B32	260	(1.15)	1.639	(41.63)	79	(0.35)	53	(0.23)
		B32A	727	(3.23)	.924	(23.47)	393	(1.75)	262	(1.16)

Based on simple beam condition using an allowable design stress of 25,000 psi (172 MPa) in accordance with MFMA, with adequate lateral bracing (see page 12 for further explanation). Actual yield point of cold rolled steel is 42,000 psi. To determine concentrated load capacity at mid span, multiply uniform load by 0.5 and corresponding deflection by 0.8. *Failure determined by weld shear.

Column Loading

Unbraced Height In. mm	Channel Style	Max. Column Loading K = .80				Max. Column Loading (Loaded @ C.G.)						
		Loaded@ C.G.		Loaded@ Slot Face		K = .65		K = 1.0		K = 1.2		
		Lbs.	kN	Lbs.	kN	Lbs.	kN	Lbs.	kN	Lbs.	kN	
12	(305)	B32	10278	(4.572)	4036	(17.95)	10432	(46.40)	10035	(44.64)	9753	(43.38)
		B32A	21320	(94.83)	6557	(29.17)	21378	(95.09)	21224	(94.41)	21106	(93.88)
24	(609)	B32	9104	(40.49)	3732	(16.60)	9600	(42.70)	8387	(37.31)	7640	(33.98)
		B32A	20806	(92.55)	6431	(28.60)	21039	(93.58)	20421	(90.84)	19950	(88.74)
36	(914)	B32	7640	(33.98)	3323	(14.78)	8479	(37.71)	6520	(29.00)	5425	(24.13)
		B32A	19950	(88.74)	6228	(27.70)	20474	(91.07)	19083	(84.88)	18023	(80.17)
48	(1219)	B32	6151	(27.36)	2877	(12.80)	7265	(32.31)	4778	(21.25)	3870	(17.21)
		B32A	18751	(83.41)	5954	(26.48)	19682	(87.55)	17210	(76.55)	15326	(68.17)
60	(1524)	B32	4778	(21.25)	2435	(10.83)	6060	(26.95)	3693	(16.43)	2994	(13.32)
		B32A	17210	(76.55)	4692	(20.87)	18665	(83.02)	14801	(65.84)	11858	(52.75)
72	(1829)	B32	3870	(17.21)	2089	(9.29)	4923	(21.90)	2994	(13.32)	2403	(10.68)
		B32A	15326	(68.17)	3448	(15.34)	17421	(77.49)	11858	(52.75)	8316	(36.99)
84	(2133)	B32	3243	(14.42)	1817	(8.08)	4114	(18.30)	2489	(11.07)	1807**	(8.04)
		B32A	13100	(58.27)	2609	(11.60)	15951	(70.95)	8798	(39.13)	6110	(27.18)
96	(2438)	B32	2774	(12.34)	1594	(7.09)	3531	(15.70)	1993	(8.86)	1384**	(6.15)
		B32A	10525	(46.82)	2014	(8.96)	14256	(63.41)	6736	(29.96)	4678	(20.81)
108	(2743)	B32	2403	(10.69)	1407	(6.26)	3083	(13.71)	1574**	(7.00)	1093**	(4.86)
		B32A	8316	(36.99)	1592	(7.08)	12334	(54.86)	5322	(23.67)	3696**	(16.44)
120	(3048)	B32	1993	(8.86)	1221	(5.43)	2723	(12.11)	1275**	(5.67)	886**	(3.94)
		B32A	6736	(29.96)	1289	(5.73)	10203	(45.38)	4311	(19.17)	2994**	(13.32)

**Where the slenderness ratio $\frac{KL}{r}$ exceeds 200, and K = end fixity factor, L = actual length and r = radius of gyration.

Reference page 48 for general fitting and standard finish specifications.

B42 Channel & Combinations

B42

- Thickness: 12 Gauge (2.6 mm)
 - Standard lengths: 10' (3.05 m) & 20' (6.09 m)
 - Standard finishes: Plain, DURA GREEN™, Pre-Galvanized, Hot-Dipped Galvanized, Stainless Steel Type 304
 - Weight: 1.44 Lbs./Ft. (2.14 kg/m)
- Note: Also available in 14 gauge (1.9mm) material as B44

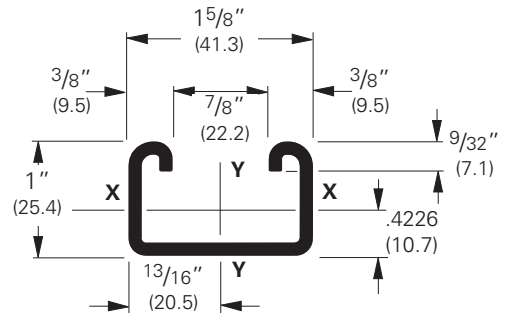
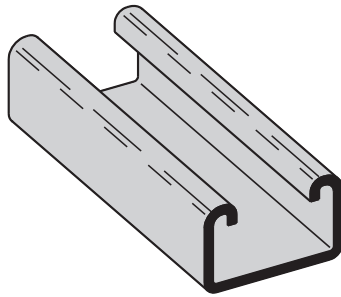

Section Properties			X - X Axis				Y - Y Axis			
Channel	Weight lbs./ft. kg/m	Areas of Section sq. in. cm ²	Moment of Inertia (I) in. ⁴ cm ⁴	Section Modulus (S) in. ³ cm ³	Radius of Gyration (r) in. cm	Moment of Inertia (I) in. ⁴ cm ⁴	Section Modulus (S) in. ³ cm ³	Radius of Gyration (r) in. cm		
B42	1.468 (2.18)	.432 (2.79)	.0554 (2.31)	.0968 (1.59)	.358 (.91)	.1645 (6.85)	.2025 (3.32)	.617 (1.57)		
B42A	2.936 (4.37)	.864 (5.57)	.2689 (11.19)	.2689 (4.41)	.558 (1.42)	.3292 (13.70)	.4052 (6.64)	.617 (1.57)		

Calculations of section properties are based on metal thicknesses as determined by the AISI Cold-Formed Steel Design Manual.

Channel & Combinations

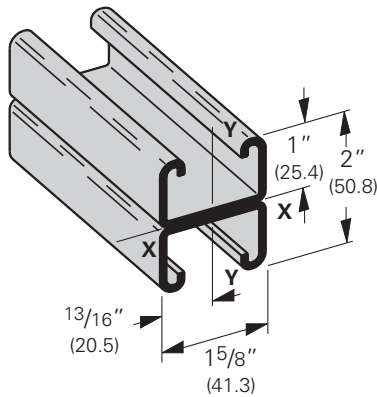

B42A
Wt. 2.88 Lbs./Ft. (4.28 kg/m)

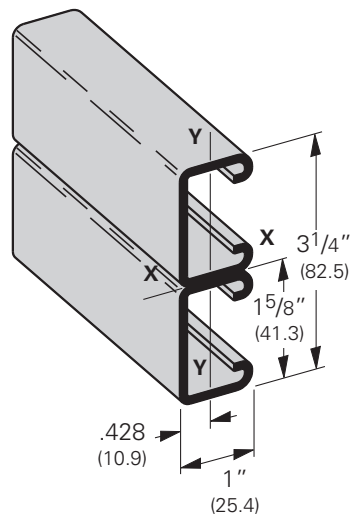

B42B
Wt. 2.88 Lbs./Ft. (4.28 kg/m)

Reference page 48 for general fitting and standard finish specifications.

B42 Beam & Column Loading Data

Beam Loading

Beam Span In. mm		Channel Style	Uniform Load and Deflection				Uniform Load @ Deflection =			
			1/240 Span		1/360 Span					
			Lbs.	kN	In.	mm	Lbs.	kN	Lbs.	kN
12	(305)	B42	1538	(6.84)	.022	(.56)	1538	(6.84)	1538	(6.84)
		B42A	1590*	(7.07)	.005	(.13)	1590*	(7.07)	1590*	(7.07)
24	(609)	B42	769	(3.42)	.088	(2.23)	769	(3.42)	582	(2.59)
		B42A	1590*	(7.07)	.038	(.96)	1590*	(7.07)	1590*	(7.07)
36	(914)	B42	513	(2.28)	.198	(5.03)	388	(1.72)	259	(1.15)
		B42A	1428	(6.35)	.114	(2.89)	1428	(6.35)	1248	(5.55)
48	(1219)	B42	384	(1.71)	.352	(8.94)	218	(0.97)	145	(0.64)
		B42A	1071	(4.76)	.203	(5.15)	1053	(4.68)	702	(3.12)
60	(1524)	B42	308	(1.37)	.550	(13.97)	140	(0.62)	93	(0.41)
		B42A	857	(3.81)	.318	(8.08)	674	(3.00)	449	(2.00)
72	(1829)	B42	256	(1.14)	.792	(20.11)	97	(0.43)	65	(0.29)
		B42A	714	(3.17)	.457	(11.61)	468	(2.08)	312	(1.39)
84	(2133)	B42	220	(0.98)	1.079	(27.40)	71	(0.31)	48	(0.21)
		B42A	612	(2.72)	.623	(15.82)	344	(1.53)	229	(1.02)
96	(2438)	B42	192	(0.85)	1.409	(35.79)	55	(0.24)	36	(0.16)
		B42A	535	(2.38)	.813	(20.65)	263	(1.17)	176	(0.78)
108	(2743)	B42	171	(0.76)	1.783	(45.29)	43	(0.19)	29	(0.13)
		B42A	476	(2.12)	1.029	(26.13)	208	(0.92)	139	(0.62)
120	(3048)	B42	154	(0.68)	2.202	(55.93)	35	(0.15)	23	(0.10)
		B42A	428	(1.90)	1.271	(32.28)	168	(0.75)	112	(0.50)

Based on simple beam condition using an allowable design stress of 25,000 psi (172 MPa) in accordance with MFMA, with adequate lateral bracing (see page 12 for further explanation). Actual yield point of cold rolled steel is 42,000 psi. To determine concentrated load capacity at mid span, multiply uniform load by 0.5 and corresponding deflection by 0.8. *Failure determined by weld shear.

Column Loading

Unbraced Height In. mm		Channel Style	Max. Column Loading K = .80				Max. Column Loading (Loaded @ C.G.)					
			Loaded @ C.G.		Loaded @ Slot Face		K = .65		K = 1.0		K = 1.2	
			Lbs.	kN	Lbs.	kN	Lbs.	kN	Lbs.	kN	Lbs.	kN
12	(305)	B42	9138	(40.65)	3493	(15.54)	9283	(41.23)	8916	(39.66)	8670	(38.56)
		B42A	21094	(93.83)	5834	(25.95)	21304	(94.76)	20793	(92.49)	20469	(91.05)
24	(609)	B42	8137	(36.19)	3145	(13.99)	8540	(37.99)	7589	(33.76)	7050	(31.36)
		B42A	19757	(87.88)	5585	(24.84)	20299	(90.29)	18964	(84.35)	18094	(80.48)
36	(914)	B42	7050	(31.36)	2722	(12.11)	7657	(34.06)	5925	(26.35)	4335	(19.28)
		B42A	18094	(80.48)	5237	(23.29)	19067	(84.81)	16654	(74.08)	15057	(66.98)
48	(1219)	B42	5405	(24.04)	2227	(9.90)	6786	(30.18)	3512	(15.62)	2439	(10.85)
		B42A	16139	(71.79)	4818	(21.43)	17632	(78.43)	13906	(61.86)	11387	(50.65)
60	(1524)	B42	3512	(15.62)	1718	(7.64)	5272	(23.45)	2247	(9.99)	1561**	(6.94)
		B42A	13906	(61.86)	4352	(19.36)	16008	(71.21)	10710	(47.64)	7531	(33.50)
72	(1829)	B42	2439	(10.85)	1351	(6.01)	3694	(16.43)	1561**	(6.94)	1084**	(4.82)
		B42A	11387	(50.65)	3856	(17.15)	14200	(64.16)	7531	(33.50)	5230	(23.26)
84	(2133)	B42	1792	(7.97)	1087	(4.83)	2714	(12.07)	1147**	(5.10)	796**	(3.54)
		B42A	8645	(38.45)	3332	(14.82)	12206	(54.29)	5533	(24.61)	3842	(17.09)
96	(2438)	B42	1372**	(6.10)	891	(3.96)	2078	(9.24)	878**	(3.90)	-	-
		B42A	6619	(29.44)	2873	(12.78)	10012	(44.53)	4236	(18.84)	2942**	(13.08)
108	(2743)	B42	1084**	(4.82)	743	(3.30)	1642	(7.30)	-	-	-	-
		B42A	5230	(23.26)	2495	(11.10)	7922	(35.24)	3347	(14.89)	2324**	(10.34)
120	(3048)	B42	878**	(3.90)	628	(2.79)	1330**	(5.91)	-	-	-	-
		B42A	4236	(18.84)	2182	(9.70)	6417	(28.54)	2711**	(12.06)	1883**	(8.37)

**Where the slenderness ratio $\frac{KL}{r}$ exceeds 200, and K = end fixity factor, L = actual length and r = radius of gyration.

Reference page 48 for general fitting and standard finish specifications.

B52 Channel & Combinations

B52

- Thickness: 12 Gauge (2.6 mm)
- Standard lengths: 10' (3.05 m) & 20' (6.09 m)
- Standard finishes: Plain, DURA GREEN™, Pre-Galvanized, Stainless Steel Type 304 or 316, Hot-Dipped Galvanized
- Weight: 1.27 Lbs./Ft. (1.89 kg/m)

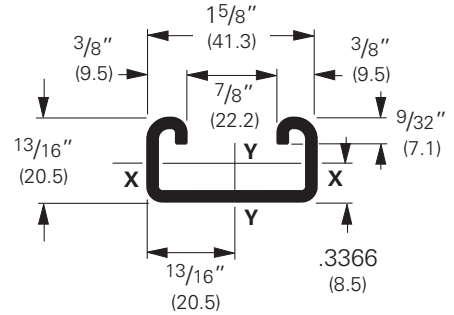
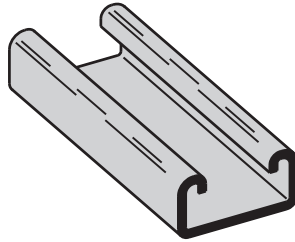

Section Properties			X - X Axis						Y - Y Axis							
Channel	Weight		Areas of Section		Moment of Inertia (I)		Section Modulus (S)		Radius of Gyration (r)		Moment of Inertia (I)		Section Modulus (S)		Radius of Gyration (r)	
	lbs./ft.	kg/m	sq. in.	cm ²	in. ⁴	cm ⁴	in. ³	cm ³	in.	cm	in. ⁴	cm ⁴	in. ³	cm ³	in.	cm
B52	1.313	(1.95)	.386	(2.49)	.0320	(1.33)	.0673	(1.10)	.288	(.73)	.1404	(5.84)	.1728	(2.83)	.603	(1.53)
B52A	2.627	(3.91)	.773	(4.99)	.1517	(6.31)	.1868	(3.06)	.443	(1.13)	.2809	(11.69)	.3457	(5.67)	.603	(1.53)

Calculations of section properties are based on metal thicknesses as determined by the AISI Cold-Formed Steel Design Manual.

Channel & Combinations

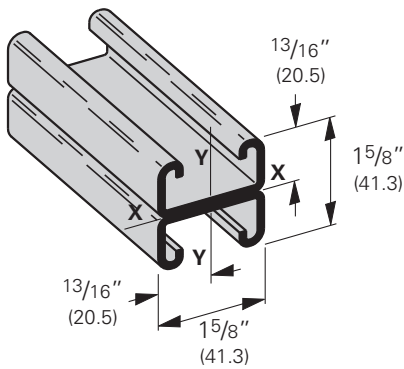

B52A
Wt. 2.54 Lbs./Ft. (3.78 kg/m)

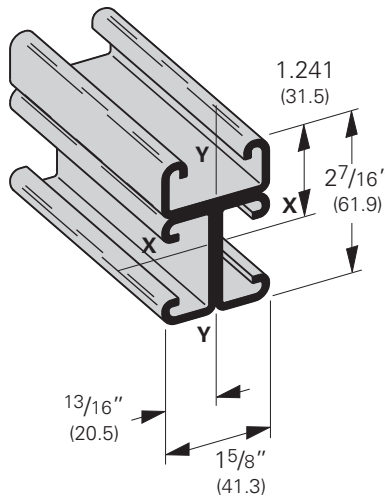

B52B3
Wt. 3.81 Lbs./Ft. (5.67 kg/m)

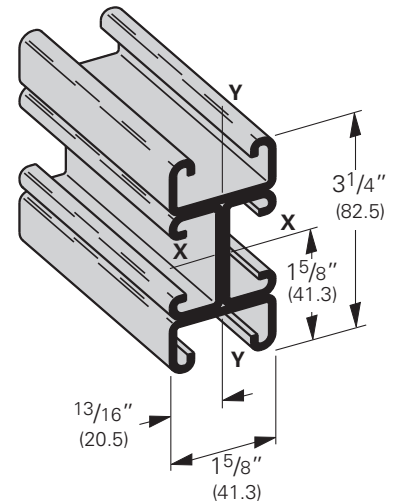

B52B4
Wt. 5.08 Lbs./Ft. (7.56 kg/m)

Reference page 48 for general fitting and standard finish specifications.

B52 Beam & Column Loading Data

Beam Loading

Beam Span In. mm	Channel Style	Uniform Load and Deflection				Uniform Load @ Deflection =			
		Lbs. kN		In. mm		1/240 Span Lbs. kN		1/360 Span Lbs. kN	
12 (305)	B52	1079	(4.80)	.026	(.66)	1079	(4.80)	1079	(4.80)
	B52A	1270*	(5.65)	.006	(.15)	1270*	(5.65)	1270*	(5.65)
24 (609)	B52	539	(2.40)	.106	(2.69)	506	(2.25)	337	(1.50)
	B52A	1270*	(5.65)	.052	(1.32)	1270*	(5.65)	1270*	(5.65)
36 (914)	B52	360	(1.60)	.240	(6.09)	225	(1.00)	150	(0.67)
	B52A	1013	(4.50)	.141	(3.58)	1013	(4.50)	719	(3.20)
48 (1219)	B52	270	(1.20)	.427	(10.84)	126	(0.56)	84	(0.37)
	B52A	759	(3.37)	.250	(6.35)	607	(2.70)	404	(1.80)
60 (1524)	B52	216	(0.96)	.667	(16.94)	81	(0.36)	54	(0.24)
	B52A	608	(2.70)	.391	(9.93)	388	(1.72)	259	(1.15)
72 (1829)	B52	180	(0.80)	.960	(24.38)	56	(0.25)	37	(0.16)
	B52A	506	(.225)	.563	(14.30)	270	(1.20)	180	(0.80)
84 (2133)	B52	154	(0.68)	1.307	(33.20)	41	(0.18)	28	(0.12)
	B52A	434	(1.93)	.766	(19.45)	198	(0.88)	132	(0.59)
96 (2438)	B52	135	(0.60)	1.707	(43.36)	32	(0.14)	21	(0.09)
	B52A	380	(1.69)	1.001	(25.42)	152	(0.67)	101	(0.45)
108 (2743)	B52	120	(0.53)	2.160	(54.86)	25	(0.11)	17	(0.07)
	B52A	338	(1.50)	1.267	(32.18)	120	(0.53)	80	(0.35)
120 (3048)	B52	108	(0.48)	2.667	(67.74)	20	(0.09)	13	(0.06)
	B52A	304	(.135)	1.564	(39.72)	97	(0.43)	65	(0.29)

Based on simple beam condition using an allowable design stress of 25,000 psi (172 MPa) in accordance with MFMA, with adequate lateral bracing (see page 12 for further explanation). Actual yield point of cold rolled steel is 42,000 psi. To determine concentrated load capacity at mid span, multiply uniform load by 0.5 and corresponding deflection by 0.8. *Failure determined by weld shear.

Column Loading

Unbraced Height In. mm	Channel Style	Max. Column Loading K = .80				Max. Column Loading (Loaded @ C.G.)					
		Loaded@ C.G.		Loaded@ Slot Face		K = .65		K = 1.0		K = 1.2	
		Lbs.	kN	Lbs.	kN	Lbs.	kN	Lbs.	kN	Lbs.	kN
12 (305)	B52	8407	(37.36)	3162	(14.06)	8543	(38.00)	8205	(36.50)	7989	(35.54)
	B52A	19160	(85.23)	5290	(23.53)	19425	(86.41)	18777	(83.52)	18363	(81.68)
24 (609)	B52	7519	(33.44)	2755	(12.25)	7879	(35.05)	6521	(29.01)	5397	(24.01)
	B52A	17444	(77.59)	4955	(22.04)	18144	(80.71)	16412	(73.00)	15275	(67.94)
36 (914)	B52	5397	(24.01)	2152	(9.57)	6653	(29.59)	3616	(16.08)	2511	(11.17)
	B52A	15275	(67.94)	4496	(20.00)	16547	(73.60)	13376	(59.50)	11243	(50.01)
48 (1219)	B52	3178	(14.13)	1560	(6.94)	4785	(21.28)	2034	(9.05)	1412**	(6.28)
	B52A	12692	(56.46)	3963	(17.63)	14667	(65.24)	9683	(43.07)	6780	(30.16)
60 (1524)	B52	2034	(9.05)	1159	(5.15)	3081	(13.70)	1302**	(5.79)	904**	(4.02)
	B52A	9683	(43.07)	3383	(15.05)	12516	(55.67)	6248	(27.79)	4339	(19.30)
72 (1829)	B52	1412**	(6.28)	891	(3.96)	2139	(9.51)	904**	(4.02)	-	-
	B52A	6780	(30.16)	2799	(12.45)	10084	(44.85)	4339	(19.30)	3013	(13.42)
84 (2133)	B52	1038**	(4.62)	704	(3.13)	1572	(6.99)	664**	(2.95)	-	-
	B52A	4981	(22.15)	2337	(10.39)	7545	(33.56)	3188	(14.18)	2214**	(9.85)
96 (2438)	B52	794**	(3.53)	570	(2.53)	1203**	(5.35)	-	-	-	-
	B52A	3814	(16.96)	1973	(8.77)	5777	(25.70)	2441**	(10.86)	1695**	(7.54)
108 (2743)	B52	-	-	470	(2.09)	951**	(4.23)	-	-	-	-
	B52A	3013	(13.40)	1684	(7.49)	4564	(20.30)	1928**	(8.57)	1339**	(5.95)
120 (3048)	B52	-	-	394	(1.75)	770**	(3.42)	-	-	-	-
	B52A	2441**	(10.86)	1452	(6.46)	3697	(16.44)	1562**	(6.95)	-	-

**Where the slenderness ratio $\frac{KL}{r}$ exceeds 200, and K = end fixity factor, L = actual length and r = radius of gyration.

Reference page 48 for general fitting and standard finish specifications.

B54 Channel & Combinations

B54

- Thickness: 14 Gauge (1.9 mm)
- Standard lengths: 10' (3.05 m) & 20' (6.09 m)
- Standard finishes: Plain, DURA GREEN™, Pre-Galvanized, Hot-Dipped Galvanized, Stainless Steel Type 304 or 316, Aluminum
- Weight: .97 Lbs./Ft. (1.44 kg/m)

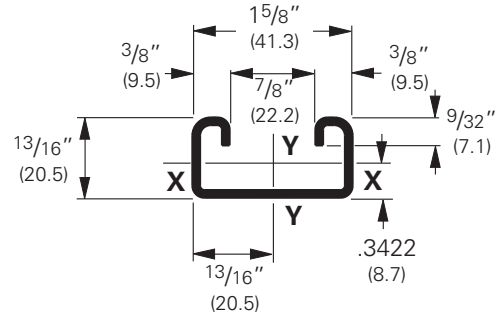
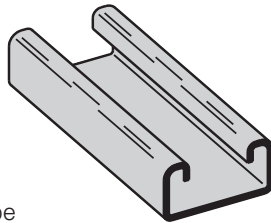

Note:
Aluminum loading, for B54 & B54A, can be determined by multiplying load data times a factor of 0.38

Section Properties			X - X Axis						Y - Y Axis							
Channel	Weight		Areas of Section		Moment of Inertia (I)		Section Modulus (S)		Radius of Gyration (r)		Moment of Inertia (I)		Section Modulus (S)		Radius of Gyration (r)	
	lbs./ft.	kg/m	sq. in.	cm ²	in. ⁴	cm ⁴	in. ³	cm ³	in.	cm	in. ⁴	cm ⁴	in. ³	cm ³	in.	cm
B54	1.016	(1.51)	.299	(1.93)	.0263	(1.09)	.0560	(.92)	.297	(.75)	.1106	(4.60)	.1361	(2.23)	.608	(1.55)
B54A	2.032	(3.02)	.598	(3.86)	.1226	(5.10)	.1510	(2.47)	.453	(1.15)	.2212	(9.12)	.2722	(4.46)	.608	(1.55)

Calculations of section properties are based on metal thicknesses as determined by the AISI Cold-Formed Steel Design Manual.

Channel & Combinations

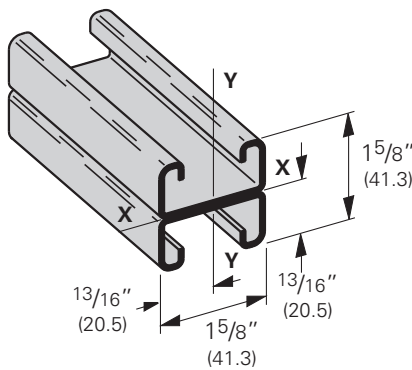

B54A
Wt. 1.94 Lbs./Ft. (2.89 kg/m)

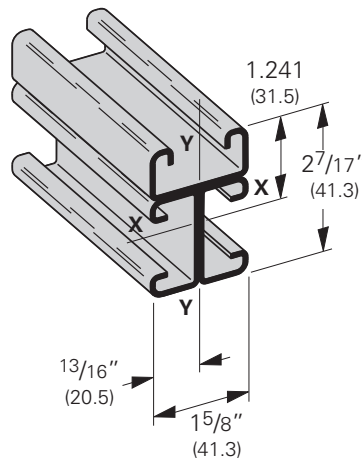

B54B3
Wt. 2.91 Lbs./Ft. (4.33 kg/m)

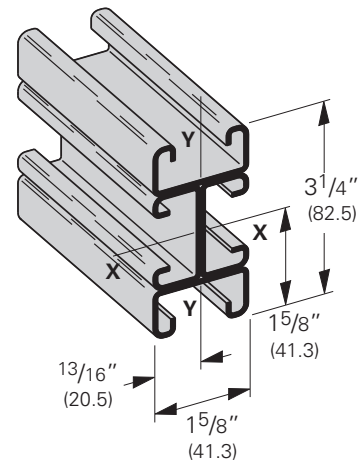

B54B4
Wt. 3.88 Lbs./Ft. (5.77 kg/m)

Reference page 48 for general fitting and standard finish specifications.

B54 Beam & Column Loading Data

Beam Loading

Beam Span In. mm	Channel Style	Uniform Load and Deflection				Uniform Load @ Deflection =			
		Lbs. kN		In. mm		1/240 Span Lbs. kN		1/360 Span Lbs. kN	
12 (305)	B54	870	(3.87)	.027	(.68)	870	(3.87)	870	(3.87)
	B54A	870*	(3.87)	.005	(.13)	870*	(3.87)	870*	(3.87)
24 (609)	B54	465	(2.07)	.108	(2.74)	430	(1.91)	287	(1.27)
	B54A	870*	(3.87)	.043	(1.09)	870*	(3.87)	870*	(3.87)
36 (914)	B54	310	(1.38)	.243	(6.17)	191	(0.85)	127	(0.56)
	B54A	832	(3.70)	.141	(3.58)	832	(3.70)	591	(2.63)
48 (1219)	B54	233	(1.03)	.432	(10.97)	108	(0.48)	72	(0.32)
	B54A	624	(2.77)	.250	(6.35)	499	(2.22)	332	(1.48)
60 (1524)	B54	186	(0.83)	.676	(17.17)	69	(0.31)	46	(0.20)
	B54A	499	(2.22)	.391	(9.93)	319	(1.42)	213	(0.95)
72 (1829)	B54	155	(0.69)	.973	(24.71)	48	(0.21)	32	(0.14)
	B54A	416	(1.85)	.563	(14.30)	222	(0.99)	148	(0.66)
84 (2133)	B54	133	(0.59)	1.324	(33.63)	35	(0.15)	23	(0.10)
	B54A	357	(1.59)	.766	(19.45)	163	(0.72)	109	(0.48)
96 (2438)	B54	116	(0.51)	1.730	(43.94)	27	(0.12)	18	(0.08)
	B54A	312	(1.39)	1.001	(25.42)	125	(0.55)	83	(0.37)
108 (2743)	B54	103	(0.46)	2.189	(55.60)	21	(0.09)	14	(0.06)
	B54A	277	(1.23)	1.267	(32.18)	98	(0.43)	66	(0.29)
120 (3048)	B54	93	(0.41)	2.703	(68.65)	17	(0.07)	11	(0.05)
	B54A	250	(1.11)	1.564	(39.72)	80	(0.35)	53	(0.23)

Based on simple beam condition using an allowable design stress of 25,000 psi (172 MPa) in accordance with MFMA, with adequate lateral bracing (see page 12 for further explanation). Actual yield point of cold rolled steel is 42,000 psi. To determine concentrated load capacity at mid span, multiply uniform load by 0.5 and corresponding deflection by 0.8. *Failure determined by weld shear.

Column Loading

Unbraced Height In. mm	Channel Style	Max. Column Loading K = .80				Max. Column Loading (Loaded @ C.G.)					
		Loaded@ C.G.		Loaded@ Slot Face		K = .65		K = 1.0		K = 1.2	
		Lbs.	kN	Lbs.	kN	Lbs.	kN	Lbs.	kN	Lbs.	kN
12 (305)	B54	6186	(27.51)	2586	(11.50)	6284	(27.95)	6032	(26.83)	5857	(26.05)
	B54A	12763	(56.77)	4060	(18.06)	12835	(57.09)	12645	(56.25)	12501	(55.61)
24 (609)	B54	5464	(24.30)	2254	(10.02)	5763	(25.63)	4968	(22.10)	4300	(19.13)
	B54A	12135	(53.98)	3857	(17.16)	12420	(55.25)	11663	(51.88)	11087	(49.32)
36 (914)	B54	4300	(19.13)	1816	(8.08)	5043	(22.43)	3076	(13.68)	2136	(9.50)
	B54A	11087	(49.32)	3549	(15.79)	11728	(52.17)	10026	(44.60)	8729	(38.83)
48 (1219)	B54	2703	(12.02)	1341	(5.96)	3920	(17.44)	1730	(7.69)	1201	(5.34)
	B54A	9620	(42.79)	3169	(14.09)	10759	(47.86)	7734	(34.40)	5571	(24.78)
60 (1524)	B54	1730	(7.69)	995	(4.42)	2621	(11.66)	1107**	(4.92)	769**	(3.42)
	B54A	7734	(34.40)	2745	(12.21)	9514	(42.32)	5134	(22.84)	3566	(15.86)
72 (1829)	B54	1201	(5.34)	763	(3.39)	1820	(8.09)	769**	(3.42)	534**	(2.37)
	B54A	5571	(24.78)	2291	(10.19)	7992	(35.50)	3566	(15.86)	2476	(11.01)
84 (2133)	B54	883**	(3.93)	603	(2.68)	1337	(5.95)	565**	(2.51)	—	—
	B54A	4093	(18.20)	1913	(8.51)	6200	(27.58)	2620	(11.65)	1819**	(8.09)
96 (2438)	B54	676**	(3.01)	487	(2.16)	1024**	(4.55)	—	—	—	—
	B54A	3134	(13.94)	1616	(7.19)	4747	(21.11)	2006**	(8.92)	1393**	(6.19)
108 (2743)	B54	534**	(2.37)	401	(1.78)	809**	(3.60)	—	—	—	—
	B54A	2476	(11.01)	1380	(6.14)	3751	(16.68)	1585**	(7.05)	1100**	(4.89)
120 (3048)	B54	—	—	336	(1.49)	655**	(2.91)	—	—	—	—
	B54A	2006**	(8.92)	1190	(5.29)	3038	(13.51)	1284**	(5.71)	—	—

**Where the slenderness ratio $\frac{KL}{r}$ exceeds 200, and K = end fixity factor, L = actual length and r = radius of gyration.

Reference page 48 for general fitting and standard finish specifications.

B56 Channel & Combinations

B56

- Thickness: 16 Gauge (1.5 mm)
- Standard lengths: 10' (3.05 m) & 20' (6.09 m)
- Standard finishes: Plain, DURA GREEN™, Pre-Galvanized, Hot-Dipped Galvanized
- Weight: .85 Lbs./Ft. (1.26 kg/m)

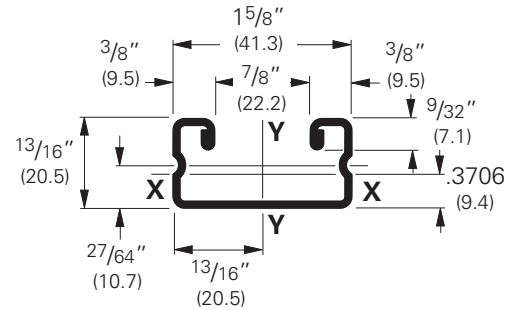
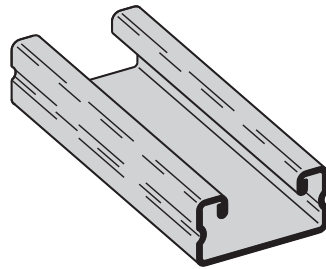

Section Properties

Channel	Weight lbs./ft. kg/m	Areas of Section sq. in. cm ²	X - X Axis			Y - Y Axis		
			Moment of Inertia (I) in. ⁴ cm ⁴	Section Modulus (S) in. ³ cm ³	Radius of Gyration (r) in. cm	Moment of Inertia (I) in. ⁴ cm ⁴	Section Modulus (S) in. ³ cm ³	Radius of Gyration (r) in. cm
B56	.894 (1.33)	.263 (1.70)	.0241 (1.00)	.0546 (.89)	.303 (.77)	.0953 (4.02)	.1189 (1.95)	.606 (1.54)
B56A	1.789 (2.66)	.526 (3.39)	.1205 (5.02)	.1484 (2.43)	.479 (1.21)	.1931 (8.04)	.2377 (3.89)	.606 (1.54)

Calculations of section properties are based on metal thicknesses as determined by the AISI Cold-Formed Steel Design Manual.

Channel & Combinations

Discontinued

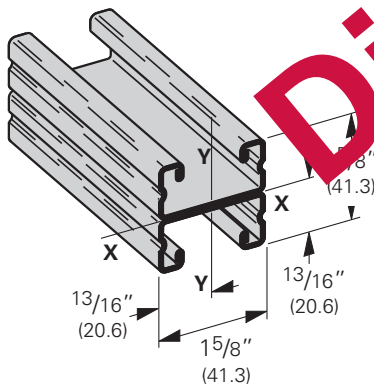

B56A
Wt. 1.70 Lbs./Ft. (2.53 kg/m)

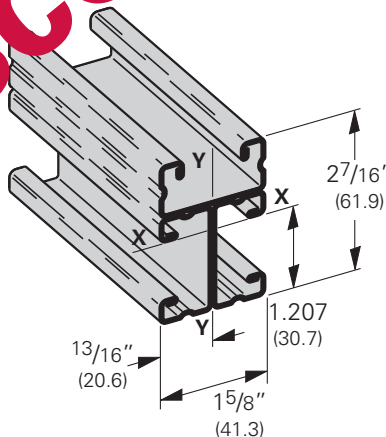

B56B3
Wt. 2.55 Lbs./Ft. (3.79 kg/m)

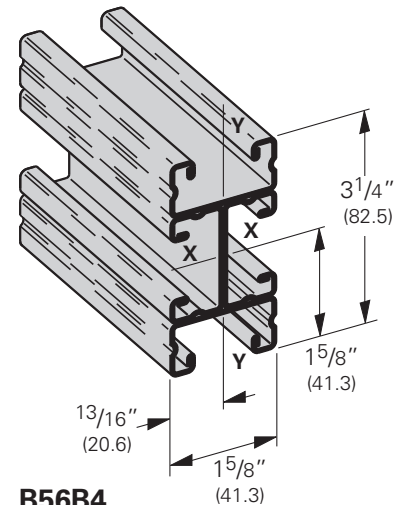

B56B4
Wt. 3.40 Lbs./Ft. (5.06 kg/m)

Reference page 48 for general fitting and standard finish specifications.

B56 Beam & Column Loading Data

Beam Loading

Beam Span In. mm	Channel Style	Uniform Load and Deflection				Uniform Load @ Deflection =			
		Lbs. kN		In. mm		1/240 Span Lbs. kN		1/360 Span Lbs. kN	
12 (305)	B56	610 (2.73)	.027 (.68)	610 (2.71)	610 (2.71)				
	B56A	610* (2.71)	.004 (.10)	610* (2.71)	610* (2.71)				
24 (609)	B56	405 (1.80)	.109 (2.77)	372 (1.65)	248 (1.10)				
	B56A	610* (2.71)	.035 (.89)	610* (2.71)	610* (2.71)				
36 (914)	B56	270 (1.20)	.245 (6.22)	165 (0.73)	110 (0.49)				
	B56A	610* (2.71)	.121 (3.07)	610* (2.71)	502 (2.23)				
48 (1219)	B56	202 (0.90)	.435 (11.05)	93 (0.41)	62 (0.27)				
	B56A	530 (2.36)	.250 (6.35)	423 (1.88)	282 (1.70)				
60 (1524)	B56	162 (0.72)	.680 (17.27)	59 (0.26)	40 (0.18)				
	B56A	424 (1.88)	.391 (9.93)	271 (1.20)	181 (0.80)				
72 (1829)	B56	135 (0.60)	.980 (24.89)	41 (0.18)	28 (0.12)				
	B56A	353 (1.57)	.563 (14.30)	188 (0.83)	125 (0.55)				
84 (2133)	B56	116 (0.51)	1.334 (33.88)	30 (0.13)	20 (0.09)				
	B56A	303 (1.35)	.766 (19.45)	138 (0.61)	92 (0.41)				
96 (2438)	B56	101 (0.45)	1.742 (44.24)	23 (0.10)	15 (0.07)				
	B56A	265 (1.18)	1.001 (25.42)	106 (0.47)	71 (0.31)				
108 (2743)	B56	90 (0.40)	2.205 (56.01)	18 (0.08)	12 (0.05)				
	B56A	236 (1.05)	1.267 (32.18)	84 (0.37)	56 (0.25)				
120 (3048)	B56	81 (0.36)	2.722 (69.14)	15 (0.06)	10 (0.04)				
	B56A	212 (0.94)	1.564 (39.72)	59 (0.26)	45 (0.20)				

Based on simple beam condition using an allowable design stress of 25,000 psi (172 MPa) in accordance with MFMA, with adequate lateral bracing (see page 12 for further explanation). Actual yield point of cold rolled steel is 42,000 psi to determine concentrated load capacity at mid span, multiply uniform load by 0.5 and corresponding deflection by 0.8. *Failure determined by weld shear.

Column Loading

Unbraced Height In. mm	Channel Style	Max. Column Loading K = 1.0				Max. Column Loading (Loaded @ C.G.)					
		Loaded @ C.G.		Loaded @ Slend. Factor		K = .65		K = 1.0		K = 1.2	
		Lbs.	kN	Lbs.	kN	Lbs.	kN	Lbs.	kN	Lbs.	kN
12 (305)	B56	4968 (22.10)	2188 (9.70)	5044 (22.44)	4845 (21.55)	4702 (20.91)					
	B56A	10237 (45.55)	3205 (14.97)	10291 (45.77)	10148 (45.14)	10039 (44.65)					
24 (609)	B56	4367 (19.38)	1903 (8.46)	4624 (20.57)	3985 (17.72)	3572 (15.89)					
	B56A	9766 (42.42)	3202 (14.24)	9977 (44.38)	9405 (41.83)	8969 (39.89)					
36 (914)	B56	3572 (15.59)	1557 (6.92)	4034 (17.94)	2658 (11.82)	1845 (8.21)					
	B56A	8329 (39.89)	2955 (13.14)	9454 (42.05)	8167 (36.33)	7186 (31.96)					
48 (1219)	B56	3335 (10.38)	1164 (5.18)	3290 (14.63)	1495 (6.65)	1038 (4.62)					
	B56A	7860 (34.96)	2649 (11.78)	8722 (38.80)	6434 (28.62)	4731 (21.04)					
60 (1524)	B56	1495 (6.65)	862 (3.83)	2264 (10.07)	957 (4.26)	664** (2.95)					
	B56A	6434 (28.62)	2307 (10.26)	7780 (34.61)	4360 (19.39)	3028 (13.47)					
72 (1829)	B56	1038 (4.62)	661 (2.94)	1572 (6.99)	664** (2.95)	461** (2.05)					
	B56A	4731 (21.04)	1937 (8.61)	6629 (29.49)	3028 (13.47)	2103 (9.35)					
84 (2133)	B56	763** (3.39)	522 (2.32)	1155 (5.14)	488** (2.17)	-					
	B56A	3476 (15.46)	1619 (7.20)	5269 (23.44)	2224 (9.89)	1545** (6.87)					
96 (2438)	B56	584** (2.60)	422 (1.88)	884** (3.93)	-	-					
	B56A	2661 (11.84)	1368 (6.08)	4031 (17.93)	1703** (7.57)	1183** (5.26)					
108 (2743)	B56	461** (2.05)	348 (1.55)	699** (3.11)	-	-					
	B56A	2103 (9.35)	1169 (5.20)	3185 (14.17)	1346** (5.99)	934** (4.15)					
120 (3048)	B56	-	291 (1.29)	566** (2.42)	-	-					
	B56A	1703** (7.57)	1008 (4.48)	2580 (11.47)	1090** (4.85)	-					

**Where the slenderness ratio $\frac{KL}{r}$ exceeds 200, and K = end fixity factor, L = actual length and r = radius of gyration.

Reference page 48 for general fitting and standard finish specifications.

Telescoping Channel

BTS22TH

- Can be secured at any point of system
- Order BTS22TH & B22TH separately
- Thickness: 12 Gauge (2.6 mm)
- Standard lengths: 10' (3.05 m)
- Standard finishes: DURA GREEN™, Yellow Zinc Dichromate, Hot-Dipped Galvanized

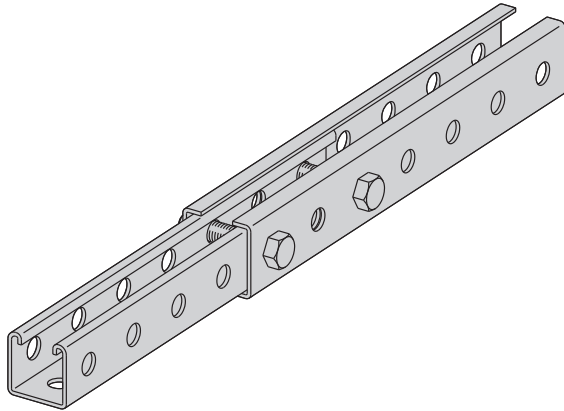

Slip Load Data

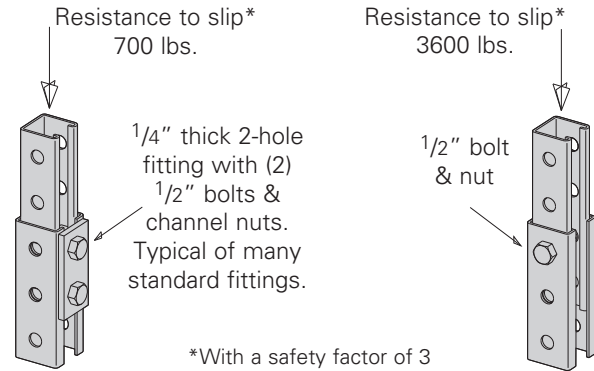

BTS22TH Telescoping Strut

Fits over all 15/8" x 15/8" channels 9/16" holes on 17/8" centers 12 gauge material thickness

Section Properties			X-X Axis				Y-Y Axis			
Channel	Weight lbs./ft.	Area In ²	C _x In	I _x In ⁴	S _x In ³	r _x In	C _y In	I _y In ⁴	S _y In ³	r _y In
BTS22TH	1.934	0.4578	1.0009	0.2525	0.2523	0.7426	0.9375	0.2757	0.2941	0.7761

Section properties are based on nominal metal thickness, and overall dimensions.

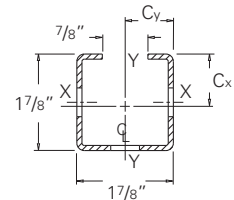

B22TH Three Hole Strut

9/16" holes on 17/8" centers 12 gauge material thickness

Section Properties			X-X Axis				Y-Y Axis			
Channel	Weight lbs./ft.	Area In ²	C _x In	I _x In ⁴	S _x In ³	r _x In	C _y In	I _y In ⁴	S _y In ³	r _y In
B22TH	1.760	0.3863	0.8245	0.1596	0.1936	0.6400	0.8125	0.1719	0.2116	0.6642

Section properties are based on nominal metal thickness, and overall dimensions.

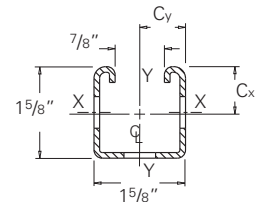

Combination of BTS22TH & B22TH

Section Properties			X-X Axis				Y-Y Axis			
Channel Combination	Weight lbs./ft.	Area In ²	C _x In	I _x In ⁴	S _x In ³	r _x In	C _y In	I _y In ⁴	S _y In ³	r _y In
BTS22TH/B22TH	3.597	0.8474	0.9773	0.4126	0.4222	0.6978	0.9375	0.4476	0.4774	0.7268

Section properties are based on nominal metal thickness, and overall dimensions.

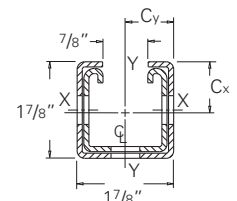

Reference page 48 for general fitting and standard finish specifications.

Beam Loading Data

B22TH

Beam Span in	Beam Load Data x-x Axis			
	Allowable Load lbs*	Resulting Deflection in	Allowable Load @ Deflection=1/240 Span	
			Lbs.	kN
12	2225	0.015	3225	(14.34)
24	1610	0.061	1610	(7.16)
36	1071	0.136	1071	(4.76)
48	800	0.243	658	(2.92)
60	637	0.379	417	(1.85)
72	528	0.546	286	(1.27)
84	449	0.743	206	(0.91)
96	390	0.970	153	(0.68)
108	344	1.228	116	(0.51)
120	306	1.516	90	(0.40)

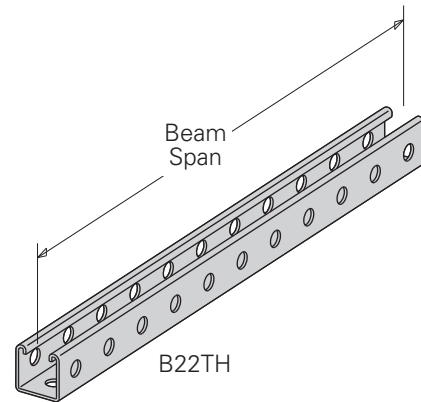

BTS22TH

Beam Span in	Beam Load Data x-x Axis			
	Allowable Load lbs*	Resulting Deflection in	Allowable Load @ Deflection=1/240 Span	
			Lbs.	kN
12	4203	0.012	4203	(18.69)
24	2099	0.050	2099	(9.33)
36	1396	0.112	1396	(6.21)
48	1044	0.200	1044	(4.64)
60	831	0.312	664	(2.95)
72	689	0.450	456	(2.03)
84	587	0.612	330	(1.48)
96	510	0.799	248	(1.10)
108	450	1.012	190	(0.84)
120	401	1.249	149	(0.66)

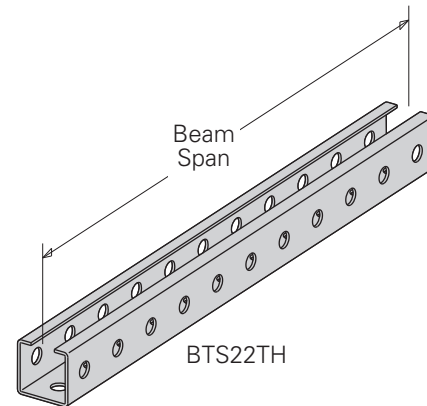

BTS22TH & B22TH Telescoping Members of Equal Length

Beam Span in	Beam Load Data x-x Axis			
	Allowable Load lbs*	Resulting Deflection in	Allowable Load @ Deflection=1/240 Span	
			Lbs.	kN
12	7033	0.013	7033	(31.28)
24	3511	0.051	3511	(15.62)
36	2335	0.115	2335	(10.38)
48	1745	0.205	1705	(7.58)
60	1389	0.320	1082	(4.81)
72	1151	0.460	742	(3.30)
84	980	0.627	536	(2.38)
96	851	0.819	401	(1.78)
108	749	1.036	307	(1.36)
120	668	1.279	239	(1.06)

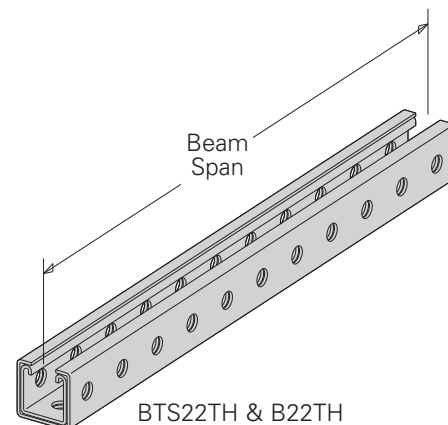

*Based on simple beam condition using an allowable design stress of 25,000 psi (172 MPa) with adequate lateral bracing (see page 12 for further explanation). To determine concentrated load capacity at mid span, multiply uniform load by 0.5 and corresponding deflection by 0.8.

Channel Hole Patterns

B11SH thru B56SH SH Type Channel

- For beam loads use 90% of Channel Loading Chart

Part No.	Thickness	Height H		Weight	
		In.	mm	Lbs./Ft.	kg/m
B11SH	12 Ga. (2.6)	3 ¹ / ₄ "	(82.5)	2.97	(4.42)
B12SH	12 Ga. (2.6)	2 ⁷ / ₁₆ "	(61.9)	2.39	(3.55)
B22SH	12 Ga. (2.6)	1 ⁵ / ₈ "	(41.3)	1.82	(2.71)
B24SH	14 Ga. (1.9)	1 ⁵ / ₈ "	(41.3)	1.34	(1.99)
B32SH	12 Ga. (2.6)	1 ³ / ₈ "	(34.9)	1.62	(2.41)
B42SH	12 Ga. (2.6)	1"	(25.4)	1.36	(2.02)
B52SH	12 Ga. (2.6)	1 ³ / ₁₆ "	(20.6)	1.19	(1.77)
B54SH	14 Ga. (1.9)	1 ³ / ₁₆ "	(20.6)	.91	(1.35)

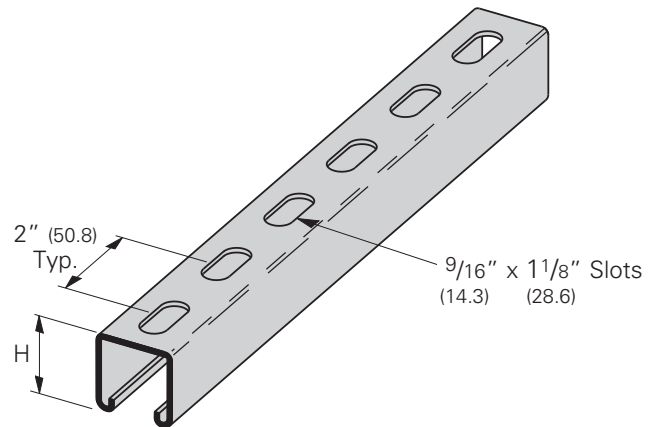

B11S thru B56S S Type Channel

- For beam loads use 90% of Channel Loading Chart

Part No.	Thickness	Height H		Weight	
		In.	mm	Lbs./Ft.	kg/m
B11S	12 Ga. (2.6)	3 ¹ / ₄ "	(82.5)	2.94	(4.37)
B12S	12 Ga. (2.6)	2 ⁷ / ₁₆ "	(61.9)	2.36	(3.51)
B22S	12 Ga. (2.6)	1 ⁵ / ₈ "	(41.3)	1.79	(2.66)
B24S	14 Ga. (1.9)	1 ⁵ / ₈ "	(41.3)	1.32	(1.96)
B32S	12 Ga. (2.6)	1 ³ / ₈ "	(34.9)	1.59	(2.36)
B42S	12 Ga. (2.6)	1"	(25.4)	1.33	(1.98)
B52S	12 Ga. (2.6)	1 ³ / ₁₆ "	(20.6)	1.16	(1.72)
B54S	14 Ga. (1.9)	1 ³ / ₁₆ "	(20.6)	.89	(1.32)

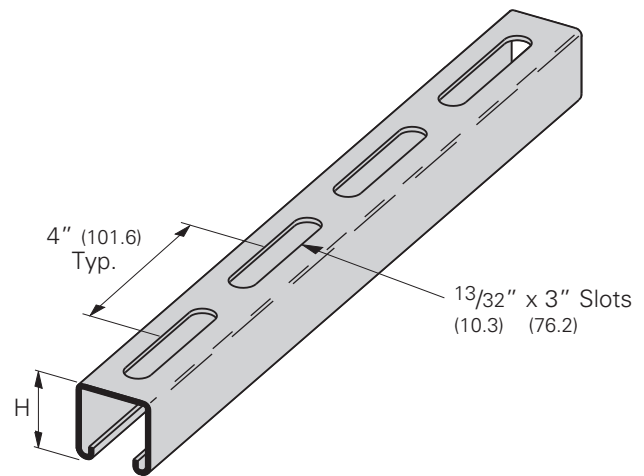

B11H17/8 thru B56H17/8 H17/8 Type Channel

- For beam loads use 90% of Channel Loading Chart

Part No.	Thickness	Height H		Weight	
		In.	mm	Lbs./Ft.	kg/m
B11H17/8	12 Ga. (2.6)	3 ¹ / ₄ "	(82.5)	3.00	(4.46)
B12H17/8	12 Ga. (2.6)	2 ⁷ / ₁₆ "	(61.9)	2.42	(3.60)
B22H17/8	12 Ga. (2.6)	1 ⁵ / ₈ "	(41.3)	1.85	(2.75)
B24H17/8	14 Ga. (1.9)	1 ⁵ / ₈ "	(41.3)	1.36	(2.02)
B32H17/8	12 Ga. (2.6)	1 ³ / ₈ "	(34.9)	1.65	(2.45)
B42H17/8	12 Ga. (2.6)	1"	(25.4)	1.39	(2.07)
B52H17/8	12 Ga. (2.6)	1 ³ / ₁₆ "	(20.6)	1.22	(1.81)
B54H17/8	14 Ga. (1.9)	1 ³ / ₁₆ "	(20.6)	.93	(1.38)

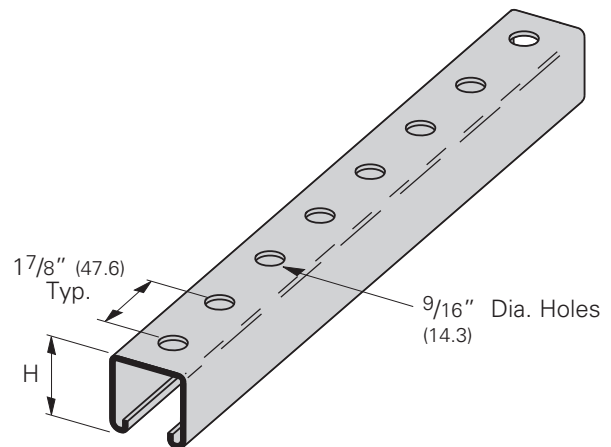

Reference page 48 for general fitting and standard finish specifications.

B22TH
TH Type Channel

• For beam loads use 90% of Channel Loading Chart

Part No.	Thickness	Height H		Weight	
		In.	mm	Lbs./Ft.	kg/m
B22TH	12 Ga. (2.6)	1 ⁵ / ₈ "	(41.3)	1.76	(2.62)

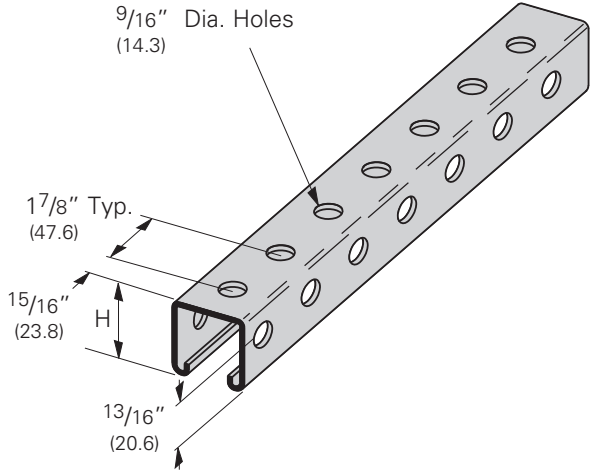

B11KO6 thru B56KO6
KO6 Type Knockout Channel

• For beam loads use 90% of Channel Loading Chart

Part No.	Thickness	Height H		Weight	
		In.	mm	Lbs./Ft.	kg/m
B11KO6	12 Ga. (2.6)	3 ¹ / ₄ "	(82.5)	3.05	(4.54)
B12KO6	12 Ga. (2.6)	2 ⁷ / ₁₆ "	(61.9)	2.47	(3.67)
B22KO6	12 Ga. (2.6)	1 ⁵ / ₈ "	(41.3)	1.90	(2.83)
B24KO6	14 Ga. (1.9)	1 ⁵ / ₈ "	(41.3)	1.40	(2.08)
B32KO6	12 Ga. (2.6)	1 ³ / ₈ "	(34.9)	1.70	(2.53)
B42KO6	12 Ga. (2.6)	1"	(25.4)	1.44	(2.14)
B52KO6	12 Ga. (2.6)	1 ³ / ₁₆ "	(20.6)	1.27	(1.89)
B54KO6	14 Ga. (1.9)	1 ³ / ₁₆ "	(20.6)	.97	(1.44)

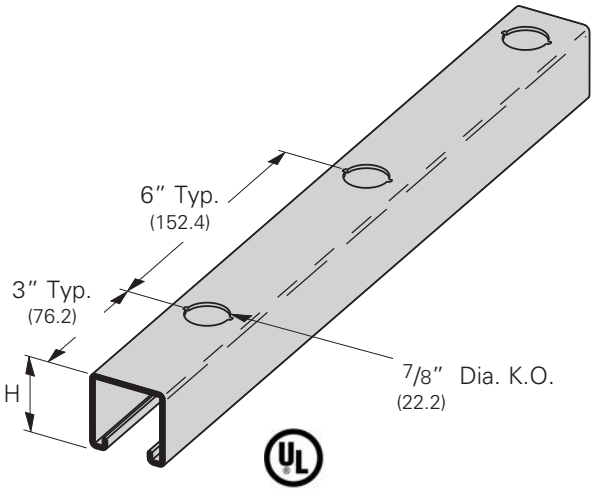

B22SHA
Back to Back SH Type Channel

• For beam loads use 90% of Channel Loading Chart

Part No.	Thickness	Height H		Weight	
		In.	mm	Lbs./Ft.	kg/m
B22SHA	12 Ga. (2.6)	3 ¹ / ₄ "	(82.5)	3.64	(5.42)
B52SHA	12 Ga. (2.6)	1 ⁵ / ₈ "	(41.3)	2.38	(1.77)
B54SHA	14 Ga. (1.9)	1 ⁵ / ₈ "	(41.3)	1.82	(1.35)

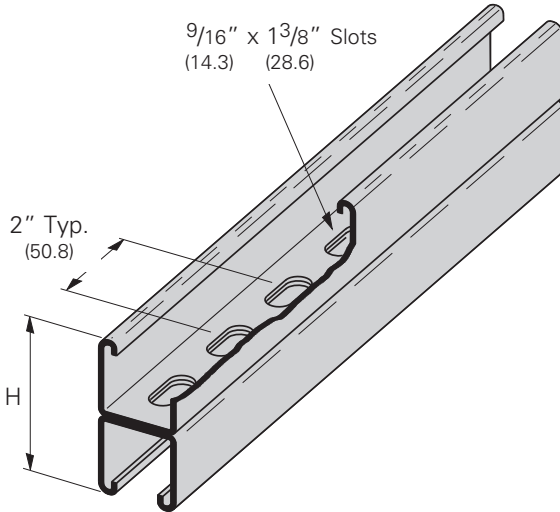

Reference page 48 for general fitting and standard finish specifications.

Channel Hole Patterns

B11S58 thru B56S58 S58 Type Channel

- For beam loads use 90% of Channel Loading Chart

Part No.	Thickness	Height H		Weight	
		In.	mm	Lbs./Ft.	kg/m
B11S58	12 Ga. (2.6)	3 ¹ / ₄ "	(82.5)	2.94	(4.37)
B12S58	12 Ga. (2.6)	2 ⁷ / ₁₆ "	(61.9)	2.36	(3.51)
B22S58	12 Ga. (2.6)	1 ⁵ / ₈ "	(41.3)	1.79	(2.66)
B24S58	14 Ga. (1.9)	1 ⁵ / ₈ "	(41.3)	1.32	(1.96)
B32S58	12 Ga. (2.6)	1 ³ / ₈ "	(34.9)	1.59	(2.36)
B42S58	12 Ga. (2.6)	1"	(25.4)	1.33	(1.98)
B52S58	12 Ga. (2.6)	1 ³ / ₁₆ "	(20.6)	1.16	(1.72)
B54S58	14 Ga. (1.9)	1 ³ / ₁₆ "	(20.6)	.89	(1.32)

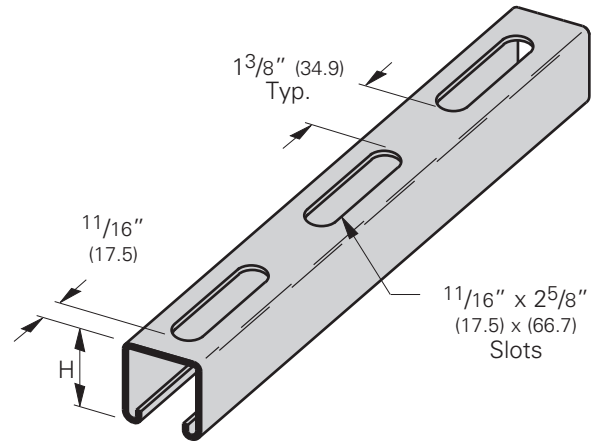

B22M thru B54M M (Marine Rung) Type Channel

- For beam loads use 90% of Channel Loading Chart

Part No.	Thickness	Height H		Weight	
		In.	mm	Lbs./Ft.	kg/m
B22M	12 Ga. (2.6)	1 ⁵ / ₈ "	(41.3)	1.79	(2.66)
B24M	14 Ga. (1.9)	1 ⁵ / ₈ "	(41.3)	1.32	(1.96)
B32M	12 Ga. (2.6)	1 ³ / ₈ "	(34.9)	1.59	(2.36)
B42M	12 Ga. (2.6)	1"	(25.4)	1.33	(1.98)
B44M	14 Ga. (1.9)	1"	(25.4)	0.98	(1.46)
B52M	12 Ga. (2.6)	1 ³ / ₁₆ "	(20.6)	1.16	(1.72)
B54M	14 Ga. (1.9)	1 ³ / ₁₆ "	(20.6)	.89	(1.32)

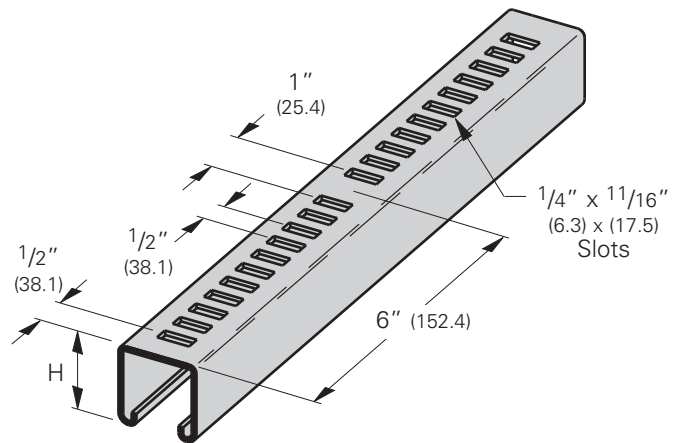

B22H25 thru B56H25 H25 Type Channel

- For beam loads use 90% of Channel Loading Chart

Part No.	Thickness	Height H		Weight	
		In.	mm	Lbs./Ft.	kg/m
B22H25	12 Ga. (2.6)	1 ⁵ / ₈ "	(41.3)	1.85	(2.75)
B24H25	14 Ga. (1.9)	1 ⁵ / ₈ "	(41.3)	1.36	(2.02)
B32H25	12 Ga. (2.6)	1 ³ / ₈ "	(34.9)	1.65	(2.45)
B42H25	12 Ga. (2.6)	1"	(25.4)	1.39	(2.07)
B52H25	12 Ga. (2.6)	1 ³ / ₁₆ "	(20.6)	1.22	(1.81)
B54H25	14 Ga. (1.9)	1 ³ / ₁₆ "	(20.6)	.93	(1.38)

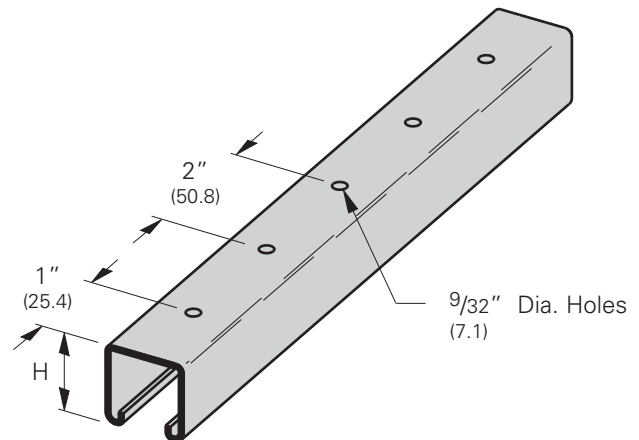

Reference page 48 for general fitting and standard finish specifications.

B217-20 Snap Closure Strip for All 1⁵/₈" (41.3) Wide Channels

- Refer to Raceway Fill Chart pages 278-279
- Material: 20 Gauge (.9)
- Standard finishes: GRN, GALV, YZN
- Standard length: 120" (3.05m)
- Wt./CFT 36 Lbs. (16.3 kg)

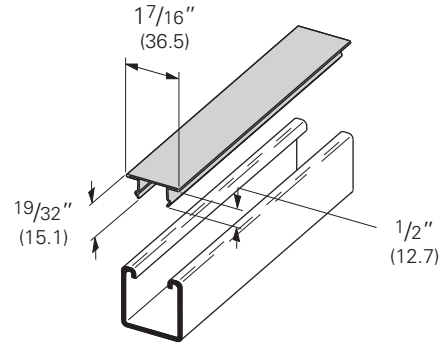

B217P Plastic Snap Closure Strip for All 1⁵/₈" (41.3) Wide Channels

- Refer to Raceway Fill Chart pages 278-279
- Standard finishes: Green (GRN) or Gray (GRY) Plastic
- Standard length: 120" (3.05m)
- Wt./CFT 9.2 Lbs. (4.2 kg)

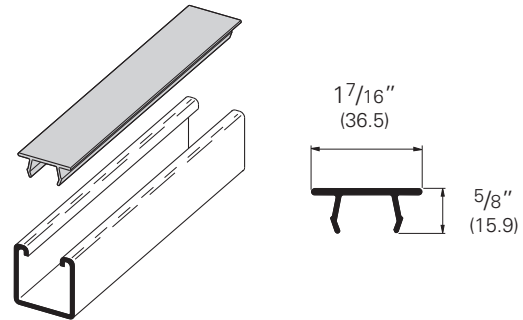

B217-24 Snap Closure Strip for All 1⁵/₈" (41.3) Wide Channels

- Refer to Raceway Fill Chart pages 278-279
- For use with 7 or fewer conductors no larger than #12 AWG
- Material: 24 Gauge (.6)
- Standard finishes: GRN, GALV, YZN
- Standard length: 120" (3.05m)
- Wt./CFT 28 Lbs. (12.7 kg)

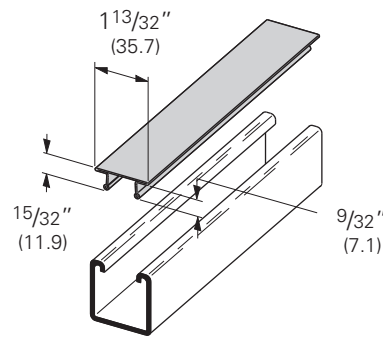

Touch Up Paint

- Used to touch up cut ends of channel
- Standard colors: Green for DURA GREEN™ & B999 for Zinc/Galv
- Weight: 12.5 ounce cans

Part No.	Description	Box Qty.
B999	Zinc/Galv color	1
960674A	Dura-Green color	1



B999



960674A

Reference page 48 for general fitting and standard finish specifications.

Channel Nuts & Hardware



Channel Nuts

Channel nuts are one of the main components of our strut system. It is designed to provide essential gripping power and ease during installation. Channel nuts are press formed, machined and hardened from steel which meets the requirements of ASTM A108 or ASTM A36 for our larger sizes.

Bolts, Screws, and Nuts

All bolts, screws and nuts meet the physical and chemical requirements of ASTM A307, SAE J429 or ASTM A563, and have unified inch screw threads (coarse, UNC). ISO metric threads are also available on special request.

Recommended Torque

Special Note:
For recommended torque on 4Dimension trapeze hangers using B200 series square washers, see page 4D08.

Bolt Size	1/4"-20	5/16"-18	3/8"-16	1/2"-13
ft-lbs	6	11	19	50
Nm	8	15	26	68

Bolt Size	M6x1	M8 x1.25	M10 x 1.5	M12x1.75
Nm	12	17	36	62
ft-lbs	9	13	27	46

Materials & Finishes*

*Unless otherwise noted.
Note: Channel nuts are not available in HDG, Aluminum, or Stainless Steel Type 304

Finish Code	Finish	Specification
PLN	Plain	ASTM A108/A307 Gr. A, ASTM A563, SAE J429
ZN	Electro-Plated Zinc	ASTM B633 SC1 Type III
CZ	Chromium Zinc	ASTM F1136 Gr. 3
HDG	Hot-Dipped Galvanized	ASTM A153
SS6	Stainless Steel Type 316	MPIF 35/ASTM F593
AL	Aluminum	ASTM F468 S4

Metric

Metric dimensions are shown in parentheses. Unless noted, all metric dimensions are in millimeters.

Note: Channel nuts and hardware are sold in full box quantities. ★

Standard Channel Nuts

Numbering Example:

N 7 25 - (*) WO

Nut Type
 N = Standard Nut
 TN = Twirl-Nut™
 SN = Stud Nut
 STN = Stud Twirl-Nut™
 NW = Combo Nut
 Washer

Channel Type
 7 = Tall Channels
 B11
 B12
 2 = Medium Channels
 B22
 B24
 B32
 5 = Short Channels
 B42
 B52
 B54

Thread Size
 21 = #8-32
 22 = #10-24
 27 = #10-32
 24 = 1/4"-20
 23 = 5/16"-18
 28 = 3/8"-16
 26 = 7/16"-14
 25 = 1/2"-13
 55 = 5/8"-11
 75 = 3/4"-10
 78 = 7/8"-9

Stud Length
 * = Specify Length
 of stud below
 for Stud Nut or
 Twirl Stud Nuts
 3/4 = 3/4"
 1 = 1"
 1 1/4 = 1 1/4"
 1 1/2 = 1 1/2"

Suffix
 WO = Without Spring
 ___ = Twirl-Nut™ or nuts
 with springs have
 blank suffix

Metric Channel Nuts

Numbering Example:

BMS - 6 M

Nut Type
 BMS = Spring Nut
 BMS-D = Spring Nut (1/2" thick)
 BMT = Twirl-Nut™
 BMT-D = Twirl-Nut™ (1/2" thick)
 BMM = Spring Nut (Mini channel)

Metric Thread Size
 3 = M3.5
 4 = M4
 5 = M5
 6 = M6
 8 = M8
 10 = M10
 12 = M12

Suffix
 S = Short Spring
 M = Medium Spring
 L = Long Spring
 ___ = Twirl-Nut™ and nuts
 without springs have
 blank suffix

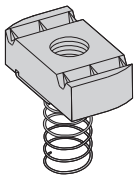

Spring Nut

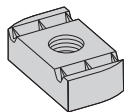

Nut without Spring

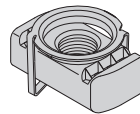

Twirl-Nut™

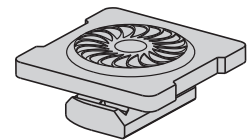

Combo Nut Washer

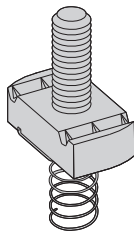

Stud Nut with Spring

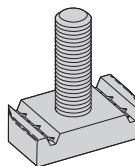

Stud Nut without Spring

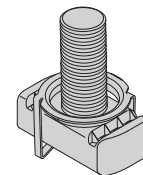

Twirl Stud Nut

Reference page 78 for general fitting and standard finish specifications.

Channel Nuts

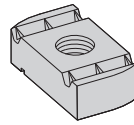

Note: See page 84 for resistance to slip & page 85 for pull-out strength.

Nut Without Spring

Part No.	Thread Size	Fits Channel Sizes	Nut Thickness		Wt./C	
			In.	mm	Lbs.	kg
N221WO	#8-32	All sizes except B62 & B72	1/4"	(6.3)	7.0	(3.17)
N227WO	#10-32	All sizes except B62 & B72	1/4"	(6.3)	7.0	(3.17)
N222WO	#10-24	All sizes except B62 & B72	1/4"	(6.3)	7.0	(3.17)
N224WO	1/4-20	All sizes except B62 & B72	1/4"	(6.3)	6.7	(3.04)
N223WO	5/16-18	All sizes except B62 & B72	1/4"	(6.3)	6.7	(3.04)
N228WO	3/8-16	All sizes except B62 & B72	3/8"	(9.5)	9.3	(4.22)
N226WO	7/16-14	All sizes except B62 & B72	3/8"	(9.5)	8.8	(3.99)
N225WO	1/2-13	B11, B12, B22, B24, B32	1/2"	(12.7)	11.6	(5.26)
N525WO	1/2-13	B42, B52, B54	3/8"	(9.5)	8.8	(3.99)
N255WO	5/8-11	B11, B12, B22, B24, B32	1/2"	(12.7)	16.4	(7.44)
N555WO	5/8-11	B42, B52, B54	3/8"	(9.5)	10.2	(4.62)
N275WO	3/4-10	B11, B12, B22, B24, B32	1/2"	(12.7)	14.5	(6.58)
N575WO	3/4-10	B42, B52, B54	3/8"	(9.5)	8.8	(3.99)
N278WO	7/8-9	B11, B12, B22, B24, B32	1/2"	(12.7)	12.5	(5.67)

Metric Threads

BMS-6	M6 x 1	All sizes except B62 & B72	1/4"	(6.3)	6.9	(3.13)
BMS-8	M8 x 1.25	All sizes except B62 & B72	1/4"	(6.3)	6.7	(3.04)
BMS-10	M10 x 1.5	All sizes except B62 & B72	3/8"	(9.5)	9.6	(4.35)
BMS-12	M12 x 1.75	All sizes except B62 & B72	3/8"	(9.5)	9.2	(4.17)
BMS-D-12	M12 x 1.75	B11, B12, B22, B24, B32	1/2"	(12.7)	12.2	(5.53)

Note: For mini channel nut information see page 245.

Reference page 78 for general fitting and standard finish specifications.

Note: See page 84 for resistance to slip & page 85 for pull-out strength.

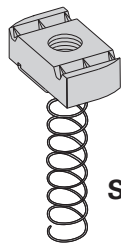

700 Series

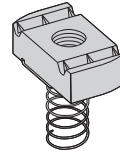

200 Series

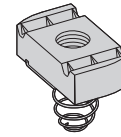

500 Series

Spring Nut

Part No.	Thread Size	Fits Channel Sizes	Nut Thickness		Wt./C	
			In.	mm	Lbs.	kg
N721	#8-32	B11 & B12	1/4"	(6.3)	7.0	(3.17)
N221	#8-32	B22, B24, B32	1/4"	(6.3)	7.0	(3.17)
N521	#8-32	B42, B52, B54	1/4"	(6.3)	7.0	(3.17)
N727	#10-32	B11 & B12	1/4"	(6.3)	7.0	(3.17)
N227	#10-32	B22, B24, B32	1/4"	(6.3)	7.0	(3.17)
N527	#10-32	B42, B52, B54	1/4"	(6.3)	7.0	(3.17)
N722	#10-24	B11 & B12	1/4"	(6.3)	7.0	(3.17)
N222	#10-24	B22, B24, B32	1/4"	(6.3)	7.0	(3.17)
N522	#10-24	B42, B52, B54	1/4"	(6.3)	7.0	(3.17)
N724	1/4-20	B11 & B12	1/4"	(6.3)	6.7	(3.04)
N224	1/4-20	B22, B24, B32	1/4"	(6.3)	6.7	(3.04)
N524	1/4-20	B42, B52, B54	1/4"	(6.3)	6.7	(3.04)
N723	5/16-18	B11 & B12	1/4"	(6.3)	6.7	(3.04)
N223	5/16-18	B22, B24, B32	1/4"	(6.3)	6.7	(3.04)
N523	5/16-18	B42, B52, B54	1/4"	(6.3)	6.7	(3.04)
N728	3/8-16	B11 & B12	3/8"	(9.5)	9.3	(4.22)
N228	3/8-16	B22, B24, B32	3/8"	(9.5)	9.3	(4.22)
N528	3/8-16	B42, B52, B54	3/8"	(9.5)	9.3	(4.22)
N726	7/16-14	B11 & B12	3/8"	(9.5)	8.8	(3.99)
N226	7/16-14	B22, B24, B32	3/8"	(9.5)	8.8	(3.99)
N526	7/16-14	B42, B52, B54	3/8"	(9.5)	8.8	(3.99)
N725	1/2-13	B11 & B12	1/2"	(12.7)	11.6	(5.26)
N225	1/2-13	B22, B24, B32	1/2"	(12.7)	11.6	(5.26)
N525	1/2-13	B42, B52, B54	3/8"	(9.5)	8.8	(3.99)
N755	5/8-11	B11 & B12	1/2"	(12.7)	16.4	(7.44)
N255	5/8-11	B22, B24, B32	1/2"	(12.7)	16.4	(7.44)
N555	5/8-11	B42, B52, B54	3/8"	(9.5)	10.2	(4.62)
N775	3/4-10	B11 & B12	1/2"	(12.7)	14.5	(6.58)
N275	3/4-10	B22, B24, B32	1/2"	(12.7)	14.5	(6.58)
N575	3/4-10	B42, B52, B54	3/8"	(9.5)	8.8	(3.99)
N778	7/8-9	B11 & B12	1/2"	(12.7)	12.5	(5.67)
N278	7/8-9	B22, B24, B32	1/2"	(12.7)	12.5	(5.67)

Metric Threads

BMS-6L	M6 x 1	B11 & B12	1/4"	(6.3)	6.9	(3.13)
BMS-6M	M6 x 1	B22, B24, B32	1/4"	(6.3)	6.9	(3.13)
BMS-6S	M6 x 1	B42, B52, B54	1/4"	(6.3)	6.9	(3.13)
BMS-8L	M8 x 1.25	B11 & B12	1/4"	(6.3)	6.7	(3.04)
BMS-8M	M8 x 1.25	B22, B24, B32	1/4"	(6.3)	6.7	(3.04)
BMS-8S	M8 x 1.25	B42, B52, B54	1/4"	(6.3)	6.7	(3.04)
BMS-10L	M10 x 1.5	B11 & B12	3/8"	(9.5)	9.6	(4.35)
BMS-10M	M10 x 1.5	B22, B24, B32	3/8"	(9.5)	9.6	(4.35)
BMS-10S	M10 x 1.5	B42, B52, B54	3/8"	(9.5)	9.6	(4.35)
BMS-12M	M12 x 1.75	B22, B24, B32	3/8"	(9.5)	9.2	(4.17)
BMS-12S	M12 x 1.75	B42, B52, B54	3/8"	(9.5)	9.2	(4.17)
BMS-D-12L	M12 x 1.75	B11 & B12	1/2"	(12.7)	12.2	(5.53)
BMS-D-12M	M12 x 1.75	B22, B24, B32	1/2"	(12.7)	12.2	(5.53)

Note: For mini channel nut information see page 245.

Reference page 78 for general fitting and standard finish specifications.

Channel Nuts

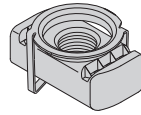

Note: See page 84 for resistance to slip & page 85 for pull-out strength.

Twirl-Nut™

Part No.	Thread Size	Fits Channel Sizes	Nut Thickness		Wt./C	
			In.	mm	Lbs.	kg
TN221	#8-32	All sizes except B62 & B72	1/4"	(6.3)	7.0	(3.17)
TN227	#10-32	All sizes except B62 & B72	1/4"	(6.3)	7.0	(3.17)
TN222	#10-24	All sizes except B62 & B72	1/4"	(6.3)	7.0	(3.17)
TN224	1/4-20	All sizes except B62 & B72	1/4"	(6.3)	6.7	(3.04)
TN223	5/16-18	All sizes except B62 & B72	1/4"	(6.3)	6.7	(3.04)
TN228	3/8-16	All sizes except B62 & B72	3/8"	(9.5)	9.3	(4.22)
TN226	7/16-14	All sizes except B62 & B72	3/8"	(9.5)	8.8	(3.99)
TN225	1/2-13	B11, B12, B22, B24, B32	1/2"	(12.7)	11.6	(5.26)
TN525	1/2-13	B42, B52, B54	3/8"	(9.5)	8.8	(3.99)
TN255	5/8-11	B11, B12, B22, B24, B32	1/2"	(12.7)	11.0	(4.99)
Metric Threads	BMT-6	M6 x 1	1/4"	(6.3)	6.9	(3.13)
	BMT-8	M8 x 1.25	1/4"	(6.3)	6.7	(3.04)
	BMT-10	M10 x 1.5	3/8"	(9.5)	9.6	(4.35)
	BMT-12	M12 x 1.75	3/8"	(9.5)	9.2	(4.17)
	BMT-D-12	M12 x 1.75	B11, B12, B22, B24, B32	1/2"	(12.7)	12.2

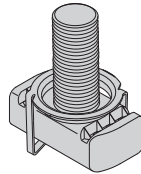

Note: See page 84 for resistance to slip & page 85 for pull-out strength.

Twirl Stud Nut

Part No.	Thread Size	Fits Channel Sizes	Nut Thickness		Wt./C	
			In.	mm	Lbs.	kg
STN224-*	1/4-20	All sizes except B62 & B72	1/4"	(6.3)	8.1	(3.66)
STN228-*	3/8-16	All sizes except B62 & B72	3/8"	(9.5)	12.9	(5.85)
STN225-*	1/2-13	B11, B12, B22, B24, B32	1/2"	(12.7)	18.2	(8.23)
STN525-*	1/2-13	B42, B52, B54	3/8"	(9.5)	15.4	(6.96)

*Note: Add stud length in inches (3/4, 1, 1 1/4, 1 1/2)

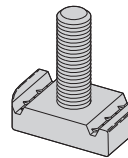

Note: See page 84 for resistance to slip & page 85 for pull-out strength.

Stud Nut Without Spring

Part No.	Thread Size	Fits Channel Sizes	Nut Thickness		Wt./C	
			In.	mm	Lbs.	kg
SN224- WO	1/4-20	All sizes except B62 & B72	1/4"	(6.3)	8.1	(3.66)
SN228- WO	3/8-16	All sizes except B62 & B72	3/8"	(9.5)	12.9	(5.85)
SN225- WO	1/2-13	B11, B12, B22, B24, B32	1/2"	(12.7)	18.2	(8.23)
SN525- WO	1/2-13	B42, B52, B54	3/8"	(9.5)	15.4	(6.96)

*Note: Add stud length in inches (3/4, 1, 1 1/4, 1 1/2)

Reference page 78 for general fitting and standard finish specifications.

Note: See page 84 for resistance to slip & page 85 for pull-out strength.

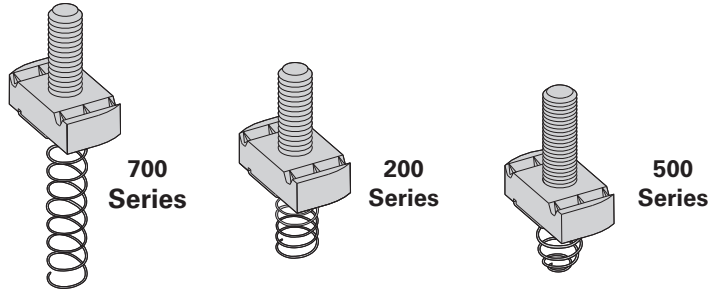

Stud Nut With Spring

Part No.	Thread Size	Fits Channel Sizes	Nut Thickness		Wt./C	
			In.	mm	Lbs.	kg
SN724-*	1/4-20	B11 & B12	1/4"	(6.3)	8.1	(3.66)
SN224-*	1/4-20	B22, B24, B32	1/4"	(6.3)	8.1	(3.66)
SN524-*	1/4-20	B42, B52, B54	1/4"	(6.3)	8.1	(3.66)
SN728-*	3/8-16	B11 & B12	3/8"	(9.5)	12.9	(5.85)
SN228-*	3/8-16	B22, B24, B32	3/8"	(9.5)	12.9	(5.85)
SN528-*	3/8-16	B42, B52, B54	3/8"	(9.5)	12.9	(5.85)
SN725-*	1/2-13	B11 & B12	1/2"	(12.7)	18.2	(8.23)
SN225-*	1/2-13	B22, B24, B32	1/2"	(12.7)	18.2	(8.23)
SN525-*	1/2-13	B42, B52, B54	3/8"	(9.5)	15.4	(6.96)

*Note: Add stud length in inches (3/4, 1, 1 1/4, 1 1/2)

- Finish: Electrodeposited zinc ASTM B633 SC1
- Available in 316 stainless steel - add SS6 to part number
- To lock combo nut washer in place a hex nut (sold separately) is required

Note: See page 84 for resistance to slip & page 85 for pull-out strength.

Patent Number
7,604,444

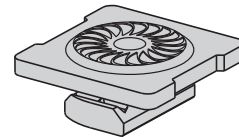

Combo Nut Washer

Part No.	Thread Size	Fits Channel Sizes	Nut Thickness		Wt./C	
			In.	mm	Lbs.	kg
NW524	1/4-20	All Channel Sizes	1/4"	(6.3)	11.9	(5.40)
NW528	3/8-16	All Channel Sizes	3/8"	(9.5)	13.8	(6.26)
NW525	1/2-13	All Channel Sizes	3/8"	(9.5)	13.1	(5.94)
NWM6	M6	All Channel Sizes	1/4"	(6.3)	16.6	(7.50)
NWM8	M8	All Channel Sizes	1/4"	(6.3)	15.4	(7.00)
NWM10	M10	All Channel Sizes	3/8"	(9.5)	18.9	(8.57)
NWM12	M12	All Channel Sizes	3/8"	(9.5)	17.7	(8.00)

Reference page 78 for general fitting and standard finish specifications.

Channel Nuts

Resistance To Slip

- With Safety Factor of 3

Thread Size	Nut Part Numbers	Resistance to Slip				
		12 ga. Channel		14 ga. Channel		
		Lbs.	N	Lbs.	N	
#8-32	N221, N221WO, N521, N721, TN221	50	220	50	220	
#10-24	N222, N222WO, N522, N722, TN222	100	440	100	440	
#10-32	N227, N227WO, N527, N727, TN227	100	440	100	440	
1/4"-20	NW524*, N224, N224WO, N524, N724, TN224, STN224, SN224WO, SN224, SN524, SN724	300	1330	300	1330	
5/16"-18	N223, N223WO, N523, N723, TN223	450	2000	450	2000	
3/8"-16	NW528*, N228, N228WO, N528, N728, TN228, STN228, SN228WO, SN228, SN528, SN728	800	3560	600	2670	
7/16"-14	N226, N226WO, N526, N726, TN226	1000	4450	800	3560	
1/2"-13	N225, N225WO, N725, TN225, STN225, SN225WO, SN225, SN725	1500	6670	1000	4450	
	NW525*, N525, N525WO, TN525, STN525, SN525WO, SN525	1500	6670	1000	4450	
5/8"-11	N255, N255WO, N755, TN255	1500	6670	1000	4450	
	N555, N555WO	1500	6670	1000	4450	
3/4"-10	N275, N275WO, N775	1500	6670	1000	4450	
	N575, N575WO	1500	6670	1000	4450	
7/8"-9	N278, N278WO, N778	1500	6670	1000	4450	
Metric Threads	M6 x 1	BMS-6, BMS-6L, BMS-6M, BMS-6S, BMT-6	300	1330	300	1330
	M8 x 1.25	BMS-8, BMS-8L, BMS-8M, BMS-8S, BMT-8	450	2000	450	2000
	M10 x 1.50	BMS-10, BMS-10L, BMS-10M, BMS-10S, BMT-10	800	3560	600	2760
	M12 x 1.75	BMS-D-12, BMS-D-12L, BMS-D-12M, BMT-D-12	1500	6670	1000	4450
		BMS-12, BMS-12M, BMS-12S, BMT-12	1500	6670	1000	4450

* Combo Nut Washer (see page 83)

Note:

Using stainless steel channel nuts in stainless steel channel, reduce slip loads by 50% due to hardness of material.
Using stainless steel channel nuts in aluminum channel, reduce slip loads by 70% due to hardness of material.

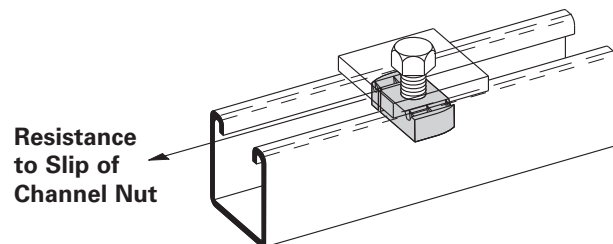

Note: For mini channel nut information see page 245.

Reference page 78 for general fitting and standard finish specifications.

Pull-Out Strength

- With Safety Factor of 3
- Maximum pullout strength for B11 & B12 channels is limited to 1500 lbs. (6670 N).

Thread Size	Nut Part Numbers	Pull-Out Strength			
		12 ga. Channel		14 ga. Channel	
		Lbs.	N	Lbs.	N
#8-32	N221, N221WO, N521, N721, TN221	200	890	200	890
#10-24	N222, N222WO, N522, N722, TN222	250	1110	250	1110
#10-32	N227, N227WO, N527, N727, TN227	250	1110	250	1110
1/4"-20	NW524*, N224, N224WO, N524, N724, TN224, STN224, SN224WO, SN224, SN524, SN724	450	2000	450	2000
5/16"-18	N223, N223WO, N523, N723, TN223	750	3330	750	3330
3/8"-16	NW528*, N228, N228WO, N528, N728, TN228, STN228, SN228WO, SN228, SN528, SN728	1100	4890	1000	4450
7/16"-14	N226, N226WO, N526, N726, TN226	1500	6670	1200	5340
1/2"-13	N225, N225WO, N725, TN225, STN225, SN225WO, SN225, SN725	2000	8900	1400	6230
	NW525*, N525, N525WO, TN525, STN525, SN525WO, SN525	1500	6670	1400	6230
5/8"-11	N255, N255WO, N755, TN255	2000	8900	1400	6230
	N555, N555WO	1500	6670	1400	6230
3/4"-10	N275, N275WO, N775	2000	8900	1400	6230
	N575, N575WO	1500	6670	1400	6230
7/8"-9	N278, N278WO, N778	1500	6670	1400	6230
M6 x 1	BMS-6, BMS-6L, BMS-6M, BMS-6S, BMT-6	450	2000	450	2000
M8 x 1.25	BMS-8, BMS-8L, BMS-8M, BMS-8S, BMT-8	750	3330	750	3330
M10 x 1.50	BMS-10, BMS-10L, BMS-10M, BMS-10S, BMT-10	1100	4890	1000	4450
M12 x 1.75	BMS-D-12, BMS-D-12L, BMS-D-12M, BMT-D-12	2000	8900	1400	6230
	BMS-12, BMS-12M, BMS-12S, BMT-12	1500	6670	1400	6230

Metric Threads

* Combo Nut Washer (see page 83)

Note:

Using stainless steel channel nuts in stainless steel channel, use pull-out loads as shown above.

Using stainless steel channel nuts in aluminum channel, reduce pull-out loads by 70% due to hardness of material.

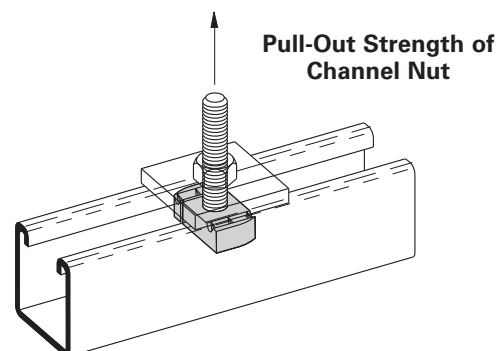

Note: For mini channel nut information see page 245.

Reference page 78 for general fitting and standard finish specifications.

DCN 3/8 Double Conveyor Nut

- Recommended torque - 19 ft./Lbs.
- Allowable slip loading - 700 Lbs.(3.11kN)
- Safety Factor of 3
- Material: ASTM 1011SS Gr. 33
- Finish: Electrodeposited zinc ASTM B633 SC1
- Strut ordered separately

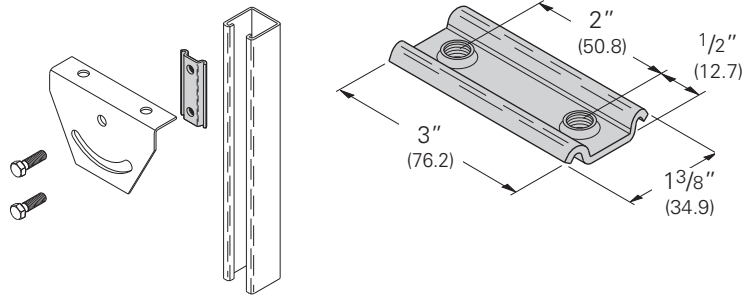

B501 Series U-Bolt

- Designed for use with Rigid Conduit or Iron Pipe
- Dimension "C" is dependent on the type of pipe or conduit supported and is a reference only

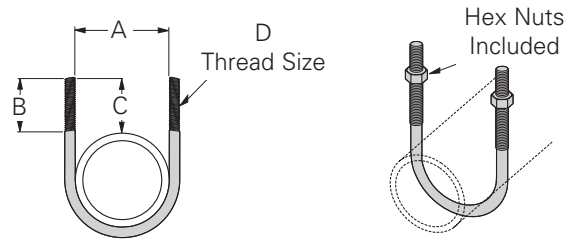

Part No.	A		B		C		D	Design Load		Wt./C	
	In.	mm	In.	mm	In.	mm		Lbs.	kN	Lbs.	kg
B501-1/2	1 5/16"	(23.8)	1 3/4"	(44.4)	1 1/2"	(38.1)	5/16"-18	600	(2.67)	12	(5.4)
B501-3/4	1 1/8"	(28.6)	1 3/4"	(44.4)	1 5/8"	(41.3)	5/16"-18	600	(2.67)	13	(5.9)
B501-1	1 3/8"	(29.9)	1 7/8"	(47.6)	1 5/8"	(41.3)	5/16"-18	900	(4.00)	14	(6.3)
B501-1 1/4	1 23/32"	(43.6)	1 3/4"	(44.4)	1 15/32"	(37.3)	5/16"-18	900	(4.00)	15	(6.8)
B501-1 1/2	2"	(50.8)	1 3/4"	(44.4)	1 7/16"	(36.5)	5/16"-18	900	(4.00)	16	(7.2)
B501-2	2 7/16"	(61.9)	2 1/16"	(52.4)	1 7/8"	(47.6)	3/8"-16	1200	(5.34)	27	(12.2)
B501-2 1/2	2 15/16"	(74.6)	2 1/16"	(52.4)	1 13/16"	(46.0)	3/8"-16	1200	(5.34)	32	(14.5)
B501-3	3 9/16"	(90.5)	2"	(50.8)	1 3/4"	(44.4)	3/8"-16	1800	(8.00)	36	(16.3)
B501-3 1/2	4 3/32"	(94.6)	2"	(50.8)	1 23/32"	(43.6)	3/8"-16	1800	(8.00)	38	(17.2)
B501-4	4 19/32"	(116.7)	2 1/4"	(57.1)	1 21/32"	(50.0)	3/8"-16	1800	(8.00)	42	(19.0)
B501-5	5 21/32"	(143.6)	2 1/4"	(57.1)	2"	(50.8)	1/2"-13	2400	(10.70)	92	(41.7)
B501-6	6 3/4"	(171.4)	2 5/8"	(66.7)	2 3/8"	(60.3)	5/8"-11	2400	(10.70)	176	(79.8)
B501-8	8 3/4"	(222.2)	2 5/8"	(66.7)	2 3/8"	(60.3)	5/8"-11	2400	(10.70)	191	(86.6)

B500 Series Square U-Bolt

- Includes:
 - 1 pc. U-Bolt only
 - 2 pcs. 3/8"-16 Hex Nuts
- Additional sizes available
- Standard finish: ZN, SS4

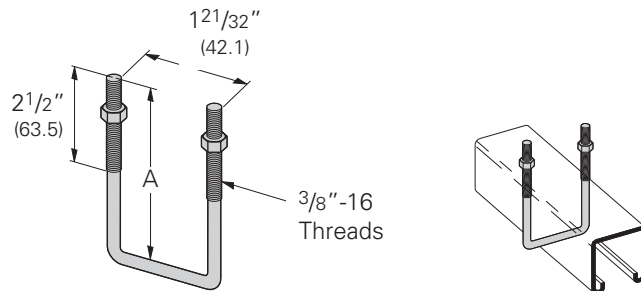

Part No.	A		Channel Size	Wt./C	
	Lbs.	kg		Lbs.	kg
B500-3-3/8	3 3/8"	(85.7)	1 5/8" x 1 5/8"	25	(11.3)
B500-5	5"	(127.0)	3 1/4" x 1 5/8"	33	(14.9)

Reference page 78 for general fitting and standard finish specifications.

HHCS ★

Hex Head Cap Screws

- Standard finish: Zinc-Plated, Stainless Steel

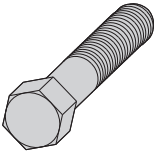

Part No.	Wt./C	
	Lbs.	kg
1/4" x 1/2" HHCS	1.3	(.59)
1/4" x 3/4" HHCS	1.4	(.63)
1/4" x 1" HHCS	1.7	(.77)
1/4" x 1 1/4" HHCS	2.1	(.95)
1/4" x 1 1/2" HHCS	2.4	(1.09)
5/16" x 1" HHCS	2.8	(1.27)
5/16" x 1 1/4" HHCS	3.2	(1.45)
5/16" x 1 1/2" HHCS	3.8	(1.72)
3/8" x 3/4" HHCS	3.4	(1.54)
3/8" x 1" HHCS	4.1	(1.86)
3/8" x 1 1/4" HHCS	4.7	(2.13)
3/8" x 1 1/2" HHCS	5.2	(2.36)
3/8" x 1 3/4" HHCS	5.9	(2.67)
3/8" x 2" HHCS	7.0	(3.17)
3/8" x 2 1/4" HHCS	7.8	(3.54)
3/8" x 2 1/2" HHCS	8.5	(3.85)
1/2" x 7/8" HHCS	8.0	(3.63)
1/2" x 1" HHCS	8.4	(3.81)
1/2" x 1 1/4" HHCS	9.2	(4.17)
1/2" x 1 1/2" HHCS	10.1	(4.58)
1/2" x 1 3/4" HHCS	12.0	(5.44)
1/2" x 2" HHCS	13.2	(5.99)
1/2" x 2 1/2" HHCS	16.0	(7.26)

SRHMS ★

Slotted Round Head Machine Screws

- Standard finish: Zinc-Plated

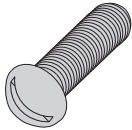

Part No.	Wt./C	
	Lbs.	kg
1/4" x 1/2" SRHMS	.9	(.41)
1/4" x 3/4" SRHMS	1.2	(.54)
1/4" x 1" SRHMS	1.5	(.68)
1/4" x 1 1/4" SRHMS	1.7	(.77)
1/4" x 1 1/2" SRHMS	1.9	(.86)
5/16" x 1" SRHMS	2.5	(1.13)
5/16" x 1 1/4" SRHMS	2.9	(1.31)
5/16" x 1 1/2" SRHMS	3.3	(1.49)
3/8" x 1" SRHMS	4.0	(1.81)
3/8" x 1 1/4" SRHMS	4.5	(2.04)
3/8" x 1 1/2" SRHMS	5.1	(2.31)
3/8" x 2" SRHMS	6.3	(2.86)
3/8" x 2 1/4" SRHMS	7.1	(3.22)
3/8" x 2 1/2" SRHMS	7.7	(3.49)

SFHMS ★

Slotted Flat Head Machine Screws

- Standard finish: Zinc-Plated

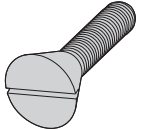

Part No.	Wt./C	
	Lbs.	kg
1/4" x 1/2" SFHMS	1.1	(.50)
1/4" x 5/8" SFHMS	1.2	(.54)
1/4" x 3/4" SFHMS	1.4	(.63)
5/16" x 1" SFHMS	2.8	(1.27)
3/8" x 1 1/2" SFHMS	5.6	(2.54)
3/8" x 2" SFHMS	6.7	(3.04)
3/8" x 2 1/4" SFHMS	7.3	(3.31)
3/8" x 2 1/2" SFHMS	7.9	(3.58)
1/2" x 1" SFHMS	5.9	(2.67)
1/2" x 1 1/4" SFHMS	7.0	(3.17)
1/2" x 1 1/2" SFHMS	8.3	(3.76)
1/2" x 2 1/2" SFHMS	13.8	(6.26)

SHHMS ★

Slotted (Combination Recess) Hex Head Machine Screws

- Standard finish: Zinc-Plated, Stainless Steel

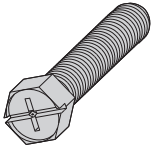

Part No.	Wt./C	
	Lbs.	kg
1/4" x 3/4" SHHMS	1.2	(.54)
1/4" x 1" SHHMS	1.5	(.68)
1/4" x 1 1/4" SHHMS	1.8	(.80)
1/4" x 1 1/2" SHHMS	2.0	(.91)
5/16" x 1" SHHMS	2.6	(1.18)
5/16" x 1 1/4" SHHMS	3.1	(1.40)
5/16" x 1 1/2" SHHMS	3.4	(1.54)
3/8" x 1 1/4" SHHMS	4.6	(2.08)
3/8" x 1 1/2" SHHMS	5.3	(2.40)

CNPSS ★

Square Head Cone Point Set Screw

- Standard finish: ZN

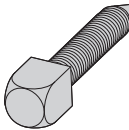

Part No.	Wt./C	
	Lbs.	kg
3/8" x 1 1/2" CNPSS	4.7	(2.13)
3/8" x 2" CNPSS	6.0	(2.72)
1/2" x 1 1/2" CNPSS	9.2	(4.17)
1/2" x 2" CNPSS	11.4	(5.17)
1/2" x 2 1/2" CNPSS	13.7	(6.21)
5/8" x 2" CNPSS	19.0	(8.62)
5/8" x 2 1/2" CNPSS	22.6	(10.25)

Channel Nuts & Hardware

Reference page 78 for general fitting and standard finish specifications.

B446A Swivel Hanger (Female Only)

- Design Load:
(³/₈)-610 Lbs. (2.71 kN)
(¹/₂)-1130 Lbs. (5.02 kN)
- Safety Factor of 3
- Standard finish: ZN

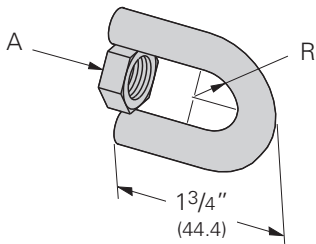

Part No.	A	R		Wt./C	
		In.	mm	Lbs.	kg
B446A- ³ / ₈	³ / ₈ "-16 HN	⁹ / ₃₂ "	(7.1)	13	(5.9)
B446A- ¹ / ₂	¹ / ₂ "-13 HN	³ / ₈ "	(9.5)	15	(6.8)

B446B Swivel Hanger (Male Only)

- Design Load:
(³/₈)-610 Lbs. (2.71 kN)
(¹/₂)-1130 Lbs. (5.02 kN)
- Safety Factor of 3
- Standard finish: ZN

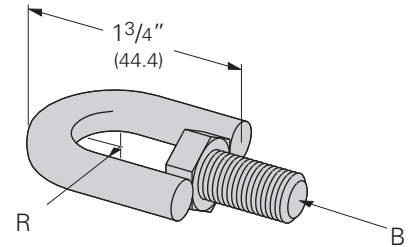

Part No.	A	R		Wt./C	
		In.	mm	Lbs.	kg
B446B- ³ / ₈	³ / ₈ "-16 HN	⁹ / ₃₂ "	(7.1)	16	(7.2)
B446B- ¹ / ₂	¹ / ₂ "-13 HN	³ / ₈ "	(9.5)	20	(9.1)

B446C Swivel Hanger (Female-Female)

- Design Load:
(³/₈)-610 Lbs. (2.71 kN)
(¹/₂)-1130 Lbs. (5.02 kN)
- Safety Factor of 3
- Standard finish: ZN

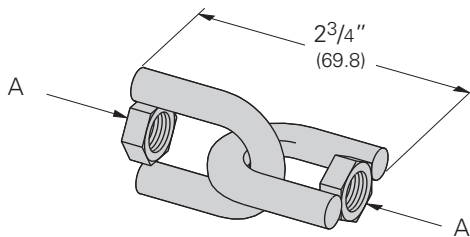

Part No.	A	Wt./C	
		Lbs.	kg
B446C- ³ / ₈	³ / ₈ "-16 HN	26	(11.8)
B446C- ¹ / ₂	¹ / ₂ "-13 HN	31	(14.0)

B446 Swivel Hanger (Female-Male)

- Design Load:
(³/₈)-610 Lbs. (2.71 kN)
(¹/₂)-1130 Lbs. (5.02 kN)
- Safety Factor of 3
- Standard finish: ZN

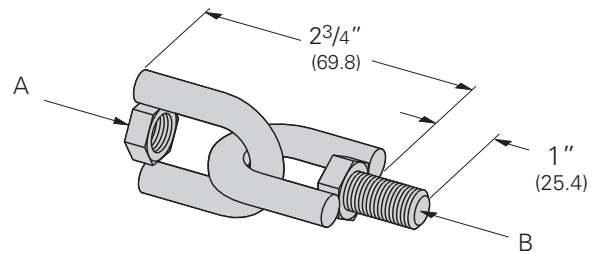

Part No.	A	B	Wt./C	
			Lbs.	kg
B446- ³ / ₈	³ / ₈ "-16 HN	³ / ₈ "-16 HHCS	28	(12.7)
B446- ¹ / ₂	¹ / ₂ "-13 HN	¹ / ₂ "-13 HHCS	36	(16.3)

Reference page 78 for general fitting and standard finish specifications.

**B617
Shoulder Bolt**

- Standard finish: ZN
- Wt./C 6 Lbs. (2.7 kg)

3/8"-16 Thread Size

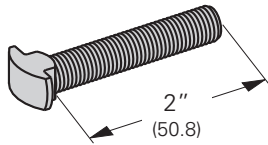

**Fig. 75
Swivel Attachment**

- Standard finish: ZN
- Sized for 3/8"-16 threaded rods
- UL Listed to support up to 4" Pipe per NFPA 13
- Wt./C 13 Lbs. (5.9 kg)

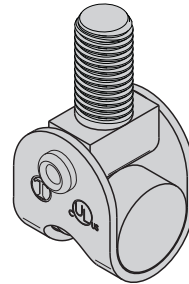

**HN ★
Hex Nuts**

- Standard finish: Zinc-Plated, Stainless Steel

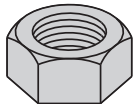

**MSQN ★
Machine Square Nut**

- For use with B755 Beam Clamp
- Standard finish: Zinc-Plated

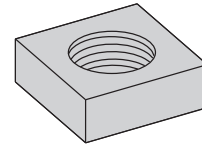

Part No.	Wt./C	
	Lbs.	kg
1/4" HN	.7	(.32)
5/16" HN	1.0	(.45)
3/8" HN	1.5	(.68)
1/2" HN	3.6	(1.63)
5/8" HN	7.2	(3.26)
3/4" HN	11.1	(5.03)
7/8" HN	17.9	(8.12)
1" HN	27.2	(12.34)

Part No.	Wt./C	
	Lbs.	kg
MSQN 1/4"	.6	(.27)
MSQN 5/16"	1.2	(.54)
MSQN 3/8"	1.8	(.81)

**SQN ★
Square Nuts**

- Standard finish: Zinc-Plated

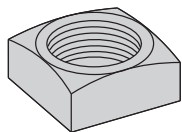

Part No.	Wt./C	
	Lbs.	kg
1/2" SQN	5.7	(2.58)
5/8" SQN	10.1	(4.58)

Channel Nuts & Hardware

Reference page 78 for general fitting and standard finish specifications.

Hardware

SLN Slip on Lock Nut

- Material: ASTM A307 Gr. A.
- Safety Factor of 3.
- Standard finish: Zinc-Plated

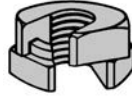

Part No.	Thread Size	B		C		Recommended Load		Wt./C	
		In.	mm	In.	mm	Lbs.	kN	Lbs.	kg
SLN-1/2	1/2"-13	1 1/8"	(28.6)	5/8"	(15.9)	1330	(5.91)	6.0	(2.7)
SLN-5/8	5/8"-11	1 5/16"	(33.3)	5/8"	(15.9)	1650	(7.34)	7.0	(3.2)

Buzznut™

- Can be installed at any desired position on the ATR, eliminating the need to thread hex nuts up along ATR.
- Loading Safety Factor of 3.
- Torque: 6 ft./lbs (8 Nm)
- Available in Zinc Plated or 316 stainless steel.

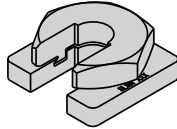

Part No.	Thread Size	Loading		Wt./C	
		Lbs.	kN	Lbs.	kg
SLWN1/4	1/4"-20	240	(1.07)	14.4	(6.5)
SLWN3/8	3/8"-16	730	(3.24)	15.4	(7.0)
SLWN1/2	1/2"-13	1350	(6.00)	18.8	(8.5)
SLWN5/8	5/8"-11	2100	(9.33)	25.4	(11.5)
SLWNM6	M6	200	(0.90)	14.1	(6.4)
SLWNM8	M8	380	(1.70)	16.3	(7.4)
SLWNM10	M10	584	(2.60)	17.2	(7.8)
SLWNM12	M12	840	(3.70)	18.9	(8.6)

FW Flat Washers

- Standard finish: Zinc-Plated, Stainless Steel

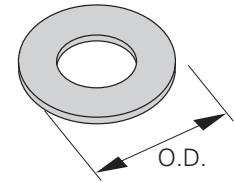

Part No.	O.D. Outside Dia.		Wt./C	
	in.	mm	Lbs.	kg
1/4" FW	47/64"	(18.7)	.7	(.32)
5/16" FW	7/8"	(22.2)	1.4	(.63)
3/8" FW	1"	(25.4)	1.7	(.77)
1/2" FW	1 3/8"	(34.9)	3.9	(1.77)
5/8" FW	1 15/32"	(37.3)	6.4	(2.90)
3/4" FW	2"	(50.8)	10.9	(4.94)
7/8" FW	2 1/4"	(57.1)	13.4	(6.08)
1" FW	2 1/2"	(63.5)	18.8	(8.53)

FFW Flat Fender Washers

- Standard finish: Zinc-Plated

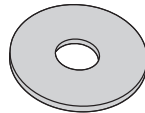

Part No.	Wt./C	
	Lbs.	kg
1/4" x 1 1/4" FFW	2.2	(1.00)
1/4" x 1 1/2" FFW	3.1	(1.40)
3/8" x 1 1/4" FFW	2.0	(.91)
3/8" x 1 1/2" FFW	3.0	(1.36)
1/2" x 2" FFW	5.4	(2.45)

LW Lock Washers

- Standard finish: Zinc-Plated, Stainless Steel

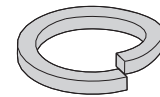

Part No.	Wt./C	
	Lbs.	kg
1/4" LW	.3	(.13)
5/16" LW	.4	(.18)
3/8" LW	.6	(.27)
1/2" LW	1.3	(.59)
5/8" LW	2.4	(1.09)
3/4" LW	3.8	(1.72)
7/8" LW	5.9	(2.67)
1" LW	8.8	(3.99)

Reference page 78 for general fitting and standard finish specifications.

**SC228
Hanger Rod Stiffener**

- For 3/8" thru 5/8" ATR
- Strut ordered separately
- Standard finish: ZN
- Wt./C 21 Lbs. (9.5 kg)

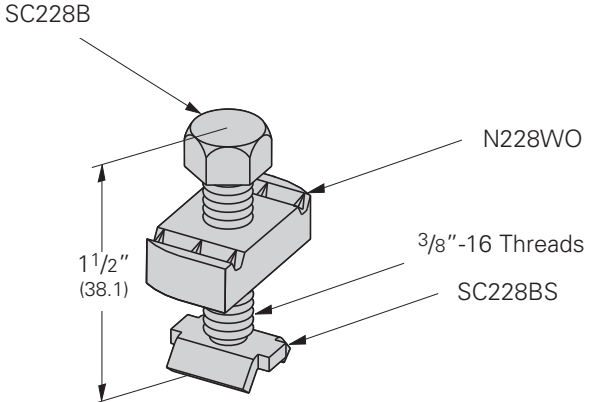
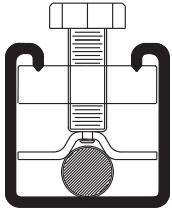

**Fig. 98
Rod Stiffener**

- For 3/8" thru 7/8" ATR
- Use with 12 ga. strut only, ordered separately
- Secures channel to hanger rod for vertical seismic bracing
- Standard finish: ZN
- Wt./C 11 Lbs. (5.0 kg)

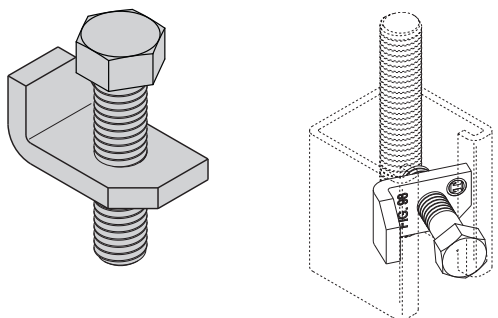

**Fig. 98B
Rod Stiffener with Break-Off Bolt Head**

- For 3/8" thru 7/8" ATR
- Use with 12 ga. strut only, ordered separately
- Secures channel to hanger rod for vertical seismic bracing
- Uses a snap-off bolt head
- Standard finish: ZN
- Wt./C 13 Lbs. (5.9 kg)

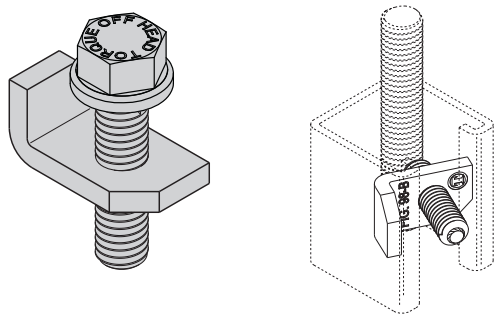

**SC-UB
Hanger Rod Stiffener**

- For 3/4" thru 7/8" ATR
- Strut ordered separately
- Includes: (1) B3188-1 1/2WO U-Bolt
(2) 3/8"-16 Hex Nuts
(1) 2-Hole Plate
- Standard finish: ZN
- Wt./C 50 Lbs. (22.7 kg)

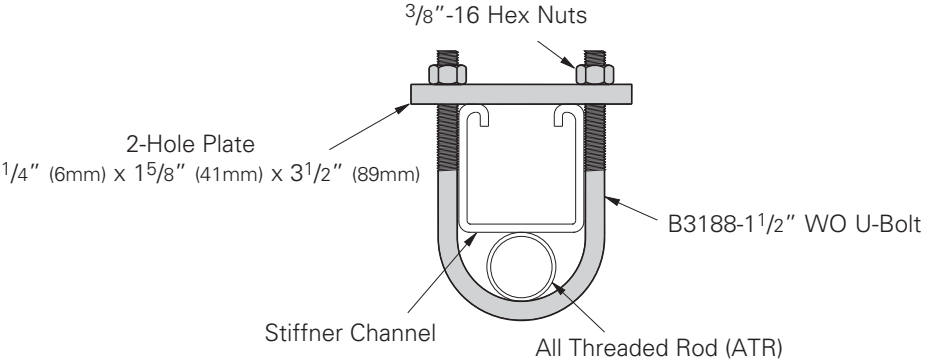

Channel Nuts & Hardware

Reference page 78 for general fitting and standard finish specifications.

Hardware

ATR

All Threaded Rod

- Available in 36" (91.4 cm), 72" (182.9 cm), 120" (304.8 cm), 144" (365.7 cm) lengths
- Safety Factor of 5 on recommended load
- Standard finish: Zinc-Plated, Stainless Steel Type 304

Part No. & Size	Threads Per Inch	Recommended Load		Wt./C Ft. (3048.0 cm)	
		Lbs.	kN	Lbs.	kg
ATR 1/4"	20	240	(1.07)	12	(5.44)
ATR 5/16"	18	400	(1.78)	19	(8.62)
ATR 3/8"	16	730	(3.24)	29	(13.15)
ATR 1/2"	13	1350	(6.00)	53	(24.04)
ATR 5/8"	11	2160	(9.60)	89	(40.37)
ATR 3/4"	10	3230	(14.37)	123	(55.79)
ATR 7/8"	9	4480	(19.93)	170	(77.11)
ATR 1"	8	5900	(26.24)	225	(102.06)

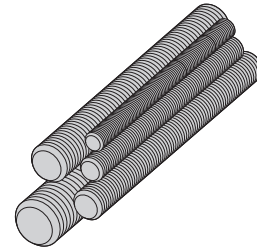

B655 Rod Coupling

- Load rating for each coupler meets All Threaded Rod value
- Standard finish: Zinc-Plated, Stainless Steel Type 304

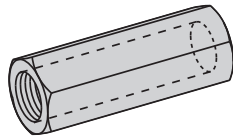

Part No.	Size	Recommended Load		Length		Wt./C	
		Lbs.	kN	In.	mm	Lbs.	kg
B655-1/4	1/4"-20	240	(1.07)	7/8"	(22.2)	1.9	(.86)
B655-5/16	5/16"-18	380	(1.69)	7/8"	(22.2)	1.8	(.81)
B655-3/8	3/8"-16	730	(3.24)	1 1/8"	(28.6)	3.6	(1.63)
B655-1/2	1/2"-13	1350	(6.00)	1 3/4"	(44.4)	11.3	(5.12)
B655-5/8	5/8"-11	1810	(8.05)	2 1/8"	(54.0)	17.6	(7.98)
B655-3/4	3/4"-10	2710	(12.05)	2 1/4"	(57.1)	28.1	(12.74)
B655-7/8	7/8"-9	3770	(16.77)	2 1/2"	(63.5)	57.2	(25.94)
B655-1	1"-8	4960	(22.06)	2 3/4"	(69.8)	73.7	(33.43)

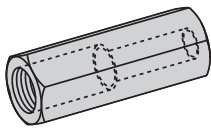

Part No.	Size	Recommended Load		Length		Wt./C	
		Lbs.	kN	In.	mm	Lbs.	kg
B656-3/8 x 1/4	3/8"-16 & 1/4"-20	240	(1.07)	1"	(25.4)	3.7	(1.68)
B656-1/2 x 3/8	1/2"-13 & 3/8"-16	730	(3.24)	1 1/4"	(31.7)	6.6	(2.99)
B656-5/8 x 1/2	5/8"-11 & 1/2"-13	1350	(6.00)	1 1/4"	(31.7)	11.6	(5.26)
B656-3/4 x 5/8	3/4"-10 & 5/8"-11	1810	(8.05)	1 1/2"	(38.1)	20.6	(9.34)
B656-7/8 x 3/4	7/8"-9 & 3/4"-10	2710	(12.05)	1 3/4"	(44.4)	39.4	(17.87)

BHR Series Hot Rods for Trapeze Hangers

- 12" length of threaded rod completely assembled with rod coupling, locking hex nuts, square washer, and channel nut.
- Standard finish: Zinc-Plated

Part No.	Rod Size	Recommended Load		Wt./C	
		Lbs.	kN	Lbs.	kg
BHR1225ZN	1/4"-20	240	(1.07)	41	(18.6)
BHR1238ZN	3/8"-16	730	(3.24)	63	(28.6)
BHR1250ZN	1/2"-13	1350	(6.00)	98	(44.4)
BHR1262ZN	5/8"-11	1500	(6.67)	148	(67.1)

Note: Based on use with 12 ga. channel.

(BHR1225, BHR1238, and BHR1250 use combo nut washers instead of square washers and channel nuts)



Reference page 78 for general fitting and standard finish specifications.



KwikWire Clamps

Part No.	For Use With Wire Rope Diameters	Box Qty.
BKC100	1/16" (1.6mm) & 3/32" (2.3mm)	100
BKC200	1/8" (3.2mm) & 3/16" (4.7mm)	50

See table below for KwikWire Clamp Working Loads

KwikWire™ Clamp Working Loads*

Clamp Part No.	Wire Rope Dia.	Lbs. Safety Factor 5
BKC100	1/16"	0-75
BKC100	3/32"	25-150
BKC200	1/8"	25-250
BKC200	3/16"	50-640

* Working loads shown are for hanging vertically.

For suspending at 15°, 30°, 45° or 60° angles from vertical, use the following percentage of the working loads from the chart:

15° = 96%
30° = 86%
45° = 70%
60° = 50%



KwikWire Wire Rope (Uncoated Galvanized Wire)

Part No.	Rope Dia.		Working Load		Spool
	in.	mm	Lbs.	kg	
BKW063 ⁽¹⁾	1/16"	(1.6)	96	(43.5)	500 ft.
BKW094 ⁽¹⁾	3/32"	(2.3)	184	(83.4)	500 ft.
BKW125 ⁽¹⁾	1/8"	(3.2)	340	(154.2)	500 ft.
BKW188 ⁽²⁾	3/16"	(4.8)	840	(381.0)	250 ft.

(1) Wire Rope Construction Type 7 x 7
(2) Wire Rope Construction Type 7 x 19

Instructions for installing the wire rope in the clamp - No tools are required.

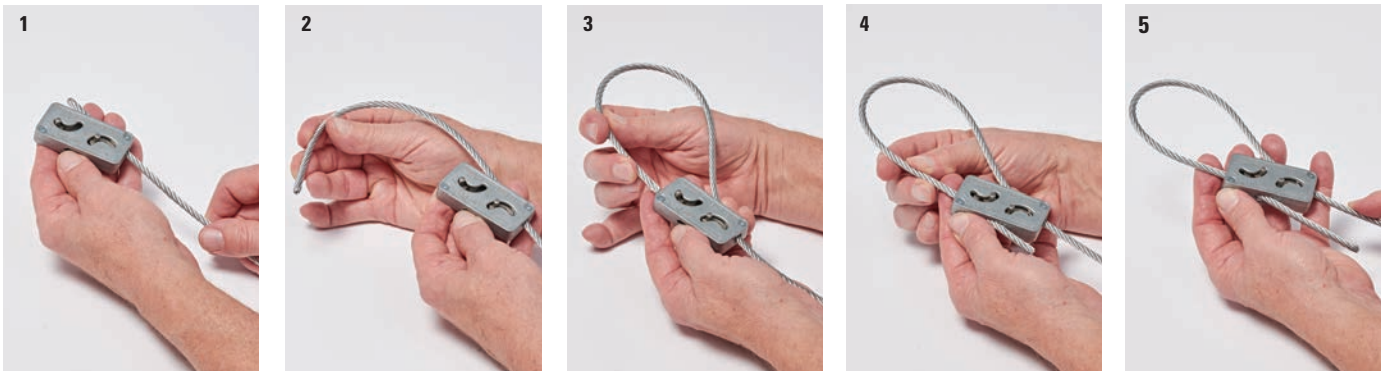

1 Pass the wire rope through the KwikWire Clamp



2 Loop wire rope through/around support



3 Pass wire rope back through KwikWire Clamp



4 Push wire rope through clamp leaving 2" to 3" tail, then apply tension on wire rope



5 To adjust, remove tension and pull wire rope slightly to disengage teeth, slide adjustment pin in direction shown by arrow to release wire rope.

Channel Nuts & Hardware



KwikPak™ Wire Rope & Clamps KwikPak

Part No.	For Use With Wire Rope Diameters	Box Qty.
BKP10063	BKC100 (100 pcs.) 1/16" Ø Wire Rope (500 ft.)	1
BKP10094	BKC100 (100 pcs.) 3/32" Ø Wire Rope (500 ft.)	1
BKP20125	BKC200 (50 pcs.) 1/8" Ø Wire Rope (500 ft.)	1
BKP20188	BKC200 (50 pcs.) 3/16" Ø Wire Rope (250 ft.)	1

- KwikPak include KwikWire clamps and a spool of wire rope.
- KwikPak is shipped in a specially designed dispenser box to ease field cutting of wire.

KwikWire™ System Recommendations:

- Do not exceed the safe working load of the products
- KwikWire Clamp load ratings are guaranteed only when used in combination with our supplied wire rope
- Do not use for overhead lifting or hoisting
- Do not use if cable or components are visibly distorted or worn. Remove damaged cable end prior to inserting in KwikWire Clamp
- Do not paint cable near working area of KwikWire Clamp
- Do not apply lubricant
- Keep product clean and free of dirt
- Do not use clamp on coated wire rope
- Do not use in chlorinated or caustic atmospheres
- For use in dry locations
- BKCC tool is recommended for cutting wire rope to prevent fraying



KwikWire Cable Cutter

Part No.	Box Qty.
BKCC	1

- Wire rope cutter for cutting all wire rope sizes
- ** **Never use cutters on energized circuits, wire, or cable.**

NEVER USE CUTTERS ON ENERGIZED CIRCUITS, WIRE, OR CABLE.



- KwikWire™ hanger combines the versatility of a bolt with an adjustable wire rope solution.
- Can be quickly installed in existing anchors or metal brackets with a nut.
- ARS, ARC, and ARW anchors are ideal for use with KwikWire Hangers.
- Ideal for supporting light fixtures, wire basket cable tray, HVAC ducts, and sign/banner supports.
- Allows for tool-less adjustment of wire rope.

KwikWire Hanger

Part No.	Thread Size	Wire Rope Dia.		Loading* SF5	
		in.	mm	Lbs.	kg
BKF100-4	1/4"-20	1/16"	(1.6)	45	(20.4)
		3/32"	(2.3)	90	(40.8)
BKF100-6	3/8"-16	1/16"	(1.6)	45	(20.4)
		3/32"	(2.3)	90	(40.8)

KwikWire Hanger installation



1
Screw KwikWire Hanger into installed hanger support (ARS anchor pictured)



2
Push cable wire up through the bottom of KwikWire Hanger



3
Continue pushing through until 1/4" minimum is extending out the side of the KwikWire Hanger



4
To adjust up - pull or push more cable wire through KwikWire Hanger



5
To adjust down - push up on bottom of KwikWire Hanger and allow cable wire to feed down



6
When hanging the cable wire is complete, cut off any excess cable wire if desired

KwikWire Accessory Features

- Reduces on the job installation time
- Can be installed quickly without drilling into existing structure
- Increases versatility in the field
- KwikWire™ accessory system reduces inventory and shipping costs
- No more sawing, filing, or fixing nuts
- Designed for use with cable tray, lighting, and HVAC
- Eliminates the need for all threaded rod
- Cost effective solution for jack chain
- “Y” style accessories require 50% less drilling

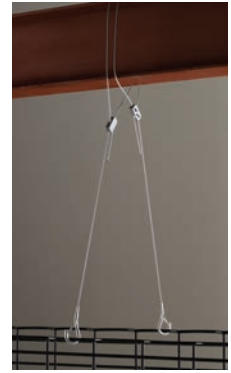

KwikWire Accessory Numbering System

Product Line	Assembly Configuration	Leg Termination	Leg Length	Wire Rope Diameter	Straight Length	Assembly or Kit
BK = KwikWire	Blank = Single Leg Y = 2 Legs 3 - 3 Legs	A = Angle Bracket w/Pin H = Hook L = Loop T = Toggle W = Fuse Cut B25 = Bolt w/ 1/4"-20 Thread B38 = Bolt w/ 3/8"-16 Thread BM6 = Bolt w/ M6 Thread BM8 = Bolt w/ M8 Thread BM10 = Bolt w/ M10 Thread	Blank = See Straight Length 18 = 18" Leg 30 = 30" Leg	063 = 1/16" 094 = 3/32"	Blank = Loop w/ Plastic Tube 18 = 18" 30 = 30" 40 = 40" 80 = 80" 120 = 120" 180 = 180" 240 = 240" 360 = 360"	Blank = Assembly Only K = Kit (Assembly & BKC100 Clamp)

Examples

BKYT18-094-120K



KwikWire Accessory
2 legs - toggle leg termination - 18" legs - 1/16" diameter wire - 120" straight length - kit with clamp

BKL-063-120K



KwikWire Accessory
single leg - looped leg termination - 1/16" diameter wire - 120" straight length - kit with clamp

KwikWire™ Loop Termination

Part No.	Wire Rope Dia.		Length	
	in.	mm	in.	mm
BKL-063-40	1/16"	(1.6)	40"	(1016)
BKL-063-80	1/16"	(1.6)	80"	(2032)
BKL-063-120	1/16"	(1.6)	120"	(3048)
BKL-063-180	1/16"	(1.6)	180"	(4572)
BKL-063-240	1/16"	(1.6)	240"	(6096)
BKL-063-360	1/16"	(1.6)	360"	(9144)
BKL-094-40	3/32"	(2.3)	40"	(1016)
BKL-094-80	3/32"	(2.3)	80"	(2032)
BKL-094-120	3/32"	(2.3)	120"	(3048)
BKL-094-180	3/32"	(2.3)	180"	(4572)
BKL-094-240	3/32"	(2.3)	240"	(6096)
BKL-094-360	3/32"	(2.3)	360"	(9144)



Box Quantity - 20

5 bags containing 4 pieces per bag

KwikWire Loop Termination Kits

Part No.	Wire Rope Dia.		Length	
	in.	mm	in.	mm
BKL-063-40K	1/16"	(1.6)	40"	(1016)
BKL-063-80K	1/16"	(1.6)	80"	(2032)
BKL-063-120K	1/16"	(1.6)	120"	(3048)
BKL-063-180K	1/16"	(1.6)	180"	(4572)
BKL-063-240K	1/16"	(1.6)	240"	(6096)
BKL-063-360K	1/16"	(1.6)	360"	(9144)
BKL-094-40K	3/32"	(2.3)	40"	(1016)
BKL-094-80K	3/32"	(2.3)	80"	(2032)
BKL-094-120K	3/32"	(2.3)	120"	(3048)
BKL-094-180K	3/32"	(2.3)	180"	(4572)
BKL-094-240K	3/32"	(2.3)	240"	(6096)
BKL-094-360K	3/32"	(2.3)	360"	(9144)



Box Quantity - 20

5 bags containing 4 pieces per bag

- Available as a wire rope with loop termination only or as a ready-to-use kit with a BKC100 clamp.
- Available in lengths of 40", 80", 120", 180", 240", and 360".

KwikWire™ Single Style Hook Termination



Box Quantity - 20
5 bags containing 4 pieces per bag



Part No.	Wire Rope Dia.		Length	
	in.	mm	in.	mm
BKH-094-40	3/32"	(2.3)	40"	(1016)
BKH-094-80	3/32"	(2.3)	80"	(2032)
BKH-094-120	3/32"	(2.3)	120"	(3048)
BKH-094-180	3/32"	(2.3)	180"	(4572)
BKH-094-240	3/32"	(2.3)	240"	(6096)
BKH-094-360	3/32"	(2.3)	360"	(9144)

KwikWire Single Style Hook Termination Kits



Box Quantity - 20
5 bags containing 4 pieces per bag



Part No.	Wire Rope Dia.		Length	
	in.	mm	in.	mm
BKH-094-40K	3/32"	(2.3)	40"	(1016)
BKH-094-80K	3/32"	(2.3)	80"	(2032)
BKH-094-120K	3/32"	(2.3)	120"	(3048)
BKH-094-180K	3/32"	(2.3)	180"	(4572)
BKH-094-240K	3/32"	(2.3)	240"	(6096)
BKH-094-360K	3/32"	(2.3)	360"	(9144)

KwikWire 'Y' Style Hook Termination With Loop



Box Quantity - 10
5 bags containing 2 pieces per bag



Part No.	Wire Rope Dia.		Length	
	in.	mm	in.	mm
BKYH18-094	3/32"	(2.3)	18"	(457)
BKYH30-094	3/32"	(2.3)	30"	(762)

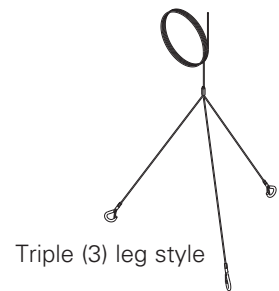

- Hook designed to accept up to 3/8" diameter wire.
- Available as a wire rope with hook termination only or as a ready-to-use kit with a BKC100 clamp.
- Available in lengths of 40", 80", 120", 180", 240", and 360".
- Available in single, double (Y), and triple (3) leg styles

KwikWire™ 'Y' Style Hook Termination

Part No.	Leg Length		Wire Rope Dia.		Length	
	in.	mm	in.	mm	in.	mm
BKYH18-094-40	18"	(457)	3/32"	(2.3)	40"	(1016)
BKYH18-094-80	18"	(457)	3/32"	(2.3)	80"	(2032)
BKYH18-094-120	18"	(457)	3/32"	(2.3)	120"	(3048)
BKYH18-094-180	18"	(457)	3/32"	(2.3)	180"	(4572)
BKYH18-094-240	18"	(457)	3/32"	(2.3)	240"	(6096)
BKYH18-094-360	18"	(457)	3/32"	(2.3)	360"	(9144)
BKYH30-094-40	30"	(762)	3/32"	(2.3)	40"	(1016)
BKYH30-094-80	30"	(762)	3/32"	(2.3)	80"	(2032)
BKYH30-094-120	30"	(762)	3/32"	(2.3)	120"	(3048)
BKYH30-094-180	30"	(762)	3/32"	(2.3)	180"	(4572)
BKYH30-094-240	30"	(762)	3/32"	(2.3)	240"	(6096)
BKYH30-094-360	30"	(762)	3/32"	(2.3)	360"	(9144)



Box Quantity - 10

5 bags containing 2 pieces per bag

KwikWire 'Y' Style Hook Termination Kits

Part No.	Leg Length		Wire Rope Dia.		Length	
	in.	mm	in.	mm	in.	mm
BKYH18-094-40K	18"	(457)	3/32"	(2.3)	40"	(1016)
BKYH18-094-80K	18"	(457)	3/32"	(2.3)	80"	(2032)
BKYH18-094-120K	18"	(457)	3/32"	(2.3)	120"	(3048)
BKYH18-094-180K	18"	(457)	3/32"	(2.3)	180"	(4572)
BKYH18-094-240K	18"	(457)	3/32"	(2.3)	240"	(6096)
BKYH18-094-360K	18"	(457)	3/32"	(2.3)	360"	(9144)
BKYH30-094-40K	30"	(762)	3/32"	(2.3)	40"	(1016)
BKYH30-094-80K	30"	(762)	3/32"	(2.3)	80"	(2032)
BKYH30-094-120K	30"	(762)	3/32"	(2.3)	120"	(3048)
BKYH30-094-180K	30"	(762)	3/32"	(2.3)	180"	(4572)
BKYH30-094-240K	30"	(762)	3/32"	(2.3)	240"	(6096)
BKYH30-094-360K	30"	(762)	3/32"	(2.3)	360"	(9144)



Box Quantity - 10

5 bags containing 2 pieces per bag

- Hook designed to accept up to 3/8" diameter wire.
- Available as a wire rope with loop termination only or as a ready-to-use kit with a BKC100 clamp.
- Available in lengths of 40", 80", 120", 180", 240", and 360".

KwikWire™ Single Style Toggle Termination



Box Quantity - 20

5 bags containing 4 pieces per bag

Part No.	Wire Rope Dia.		Length	
	in.	mm	in.	mm
BKT-063-40	1/16"	(1.6)	40"	(1016)
BKT-063-80	1/16"	(1.6)	80"	(2032)
BKT-063-120	1/16"	(1.6)	120"	(3048)
BKT-063-180	1/16"	(1.6)	180"	(4572)
BKT-063-240	1/16"	(1.6)	240"	(6096)
BKT-063-360	1/16"	(1.6)	360"	(9144)

KwikWire Single Style Toggle Termination Kits



Box Quantity - 20

5 bags containing 4 pieces per bag

Part No.	Wire Rope Dia.		Length	
	in.	mm	in.	mm
BKT-063-40K	1/16"	(1.6)	40"	(1016)
BKT-063-80K	1/16"	(1.6)	80"	(2032)
BKT-063-120K	1/16"	(1.6)	120"	(3048)
BKT-063-180K	1/16"	(1.6)	180"	(4572)
BKT-063-240K	1/16"	(1.6)	240"	(6096)
BKT-063-360K	1/16"	(1.6)	360"	(9144)

KwikWire 'Y' Style Toggle Termination With Loop



Box Quantity - 10

5 bags containing 2 pieces per bag

Part No.	Wire Rope Dia.		Length	
	in.	mm	in.	mm
BKYT12-063	1/16"	(1.6)	12"	(305)
BKYT18-063	1/16"	(1.6)	18"	(457)
BKYT30-063	1/16"	(1.6)	30"	(762)

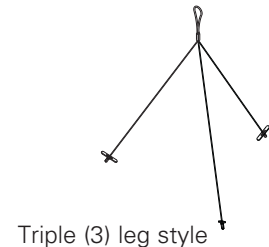

- Available as a wire rope with toggle termination only or as a ready-to-use kit with a BKC100 clamp.
- Available in lengths of 40", 80", 120", 180", 240", and 360".
- Available in single, double (Y), and triple (3) leg styles
- All triple (3) leg styles are non-stock, contact us for lead times

KwikWire™ 'Y' Style Toggle Termination

Part No.	Leg Length		Wire Rope Dia.		Length	
	in.	mm	in.	mm	in.	mm
BKYT12-063-40	12"	(305)	1/16"	(1.6)	40"	(1016)
BKYT12-063-80	12"	(305)	1/16"	(1.6)	80"	(2032)
BKYT12-063-120	12"	(305)	1/16"	(1.6)	120"	(3048)
BKYT12-063-180	12"	(305)	1/16"	(1.6)	180"	(4572)
BKYT12-063-240	12"	(305)	1/16"	(1.6)	240"	(6096)
BKYT12-063-360	12"	(305)	1/16"	(1.6)	360"	(9144)
BKYT18-063-40	18"	(457)	1/16"	(1.6)	40"	(1016)
BKYT18-063-80	18"	(457)	1/16"	(1.6)	80"	(2032)
BKYT18-063-120	18"	(457)	1/16"	(1.6)	120"	(3048)
BKYT18-063-180	18"	(457)	1/16"	(1.6)	180"	(4572)
BKYT18-063-240	18"	(457)	1/16"	(1.6)	240"	(6096)
BKYT18-063-360	18"	(457)	1/16"	(1.6)	360"	(9144)
BKYT30-063-40	30"	(762)	1/16"	(1.6)	40"	(1016)
BKYT30-063-80	30"	(762)	1/16"	(1.6)	80"	(2032)
BKYT30-063-120	30"	(762)	1/16"	(1.6)	120"	(3048)
BKYT30-063-180	30"	(762)	1/16"	(1.6)	180"	(4572)
BKYT30-063-240	30"	(762)	1/16"	(1.6)	240"	(6096)
BKYT30-063-360	30"	(762)	1/16"	(1.6)	360"	(9144)



Box Quantity - 10

5 bags containing 2 pieces per bag

KwikWire 'Y' Style Toggle Termination Kits

Part No.	Leg Length		Wire Rope Dia.		Length	
	in.	mm	in.	mm	in.	mm
BKYT12-063-40K	12"	(305)	1/16"	(1.6)	40"	(1016)
BKYT12-063-80K	12"	(305)	1/16"	(1.6)	80"	(2032)
BKYT12-063-120K	12"	(305)	1/16"	(1.6)	120"	(3048)
BKYT12-063-180K	12"	(305)	1/16"	(1.6)	180"	(4572)
BKYT12-063-240K	12"	(305)	1/16"	(1.6)	240"	(6096)
BKYT12-063-360K	12"	(305)	1/16"	(1.6)	360"	(9144)
BKYT18-063-40K	18"	(457)	1/16"	(1.6)	40"	(1016)
BKYT18-063-80K	18"	(457)	1/16"	(1.6)	80"	(2032)
BKYT18-063-120K	18"	(457)	1/16"	(1.6)	120"	(3048)
BKYT18-063-180K	18"	(457)	1/16"	(1.6)	180"	(4572)
BKYT18-063-240K	18"	(457)	1/16"	(1.6)	240"	(6096)
BKYT18-063-360K	18"	(457)	1/16"	(1.6)	360"	(9144)
BKYT30-063-40K	30"	(762)	1/16"	(1.6)	40"	(1016)
BKYT30-063-80K	30"	(762)	1/16"	(1.6)	80"	(2032)
BKYT30-063-120K	30"	(762)	1/16"	(1.6)	120"	(3048)
BKYT30-063-180K	30"	(762)	1/16"	(1.6)	180"	(4572)
BKYT30-063-240K	30"	(762)	1/16"	(1.6)	240"	(6096)
BKYT30-063-360K	30"	(762)	1/16"	(1.6)	360"	(9144)



Box Quantity - 10

5 bags containing 2 pieces per bag

- Available as a wire rope with loop termination only or as a ready-to-use kit with a BKC100 clamp.
- Available in lengths of 40", 80", 120", 180", 240", and 360".

KwikWire™ Bolt Termination



Box Quantity - 20

5 bags containing 4 pieces per bag

Part No.	Thread Size	Wire Rope Dia.		Length	
		in.	mm	in.	mm
BKB25-063-40	1/4"-20	1/16"	(1.6)	40"	(1016)
BKB25-063-80	1/4"-20	1/16"	(1.6)	80"	(2032)
BKB25-063-120	1/4"-20	1/16"	(1.6)	120"	(3048)
BKB25-063-180	1/4"-20	1/16"	(1.6)	180"	(4572)
BKB25-063-240	1/4"-20	1/16"	(1.6)	240"	(6096)
BKB25-063-360	1/4"-20	1/16"	(1.6)	360"	(9144)
BKB38-094-40	3/8"-16	3/32"	(2.3)	40"	(1016)
BKB38-094-80	3/8"-16	3/32"	(2.3)	80"	(2032)
BKB38-094-120	3/8"-16	3/32"	(2.3)	120"	(3048)
BKB38-094-180	3/8"-16	3/32"	(2.3)	180"	(4572)
BKB38-094-240	3/8"-16	3/32"	(2.3)	240"	(6096)
BKB38-094-360	3/8"-16	3/32"	(2.3)	360"	(9144)

- Ideal for use with ARS, ARC, ADI, ACPW, or ACPD anchors.
- Available as a wire rope with bolt termination only or as a ready-to-use kit with a BKC100 clamp.
- Available in lengths of 40", 80", 120", 180", 240", and 360".
- Available in single, double (Y), and triple leg (3) styles
- All (Y) and triple (3) styles are non-stock, contact us for lead times

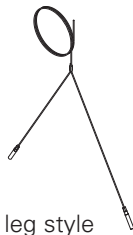

Double (Y) leg style



Triple (3) leg style

KwikWire™ Bolt Termination Kits

Part No.	Thread Size	Wire Rope Dia.		Length	
		in.	mm	in.	mm
BKB25-063-40K	1/4"-20	1/16"	(1.6)	40"	(1016)
BKB25-063-80K	1/4"-20	1/16"	(1.6)	80"	(2032)
BKB25-063-120K	1/4"-20	1/16"	(1.6)	120"	(3048)
BKB25-063-180K	1/4"-20	1/16"	(1.6)	180"	(4572)
BKB25-063-240K	1/4"-20	1/16"	(1.6)	240"	(6096)
BKB25-063-360K	1/4"-20	1/16"	(1.6)	360"	(9144)
BKB38-094-40K	3/8"-16	3/32"	(2.3)	40"	(1016)
BKB38-094-80K	3/8"-16	3/32"	(2.3)	80"	(2032)
BKB38-094-120K	3/8"-16	3/32"	(2.3)	120"	(3048)
BKB38-094-180K	3/8"-16	3/32"	(2.3)	180"	(4572)
BKB38-094-240K	3/8"-16	3/32"	(2.3)	240"	(6096)
BKB38-094-360K	3/8"-16	3/32"	(2.3)	360"	(9144)



Box Quantity - 20

5 bags containing 4 pieces per bag

- Ideal for use with ARS, ARC, ADI, ACPW, or ACPD anchors.
- Available as a wire rope with bolt termination only or as a ready-to-use kit with a BKC100 clamp.
- Available in lengths of 40", 80", 120", 180", 240", and 360".
- Available in single, double (Y), and triple (3) styles
- All double (Y) and triple (3) styles are non-stock, contact us for lead times

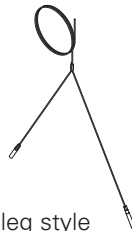

Double (Y) leg style



Triple (3) leg style

KwikWire™ Angle Bracket Termination



Box Quantity - 20

5 bags containing 4 pieces per bag

Part No.	Wire Rope Dia.		Length	
	in.	mm	in.	mm
BKA-063-40	1/16"	(1.6)	40"	(1016)
BKA-063-80	1/16"	(1.6)	80"	(2032)
BKA-063-120	1/16"	(1.6)	120"	(3048)
BKA-063-180	1/16"	(1.6)	180"	(4572)
BKA-063-240	1/16"	(1.6)	240"	(6096)
BKA-063-360	1/16"	(1.6)	360"	(9144)

KwikWire Angle Bracket Termination Kits



Box Quantity - 20

5 bags containing 4 pieces per bag

Part No.	Wire Rope Dia.		Length	
	in.	mm	in.	mm
BKA-063-40K	1/16"	(1.6)	40"	(1016)
BKA-063-80K	1/16"	(1.6)	80"	(2032)
BKA-063-120K	1/16"	(1.6)	120"	(3048)
BKA-063-180K	1/16"	(1.6)	180"	(4572)
BKA-063-240K	1/16"	(1.6)	240"	(6096)
BKA-063-360K	1/16"	(1.6)	360"	(9144)

- Available as a wire rope with angle bracket termination only or as a ready-to-use kit with a BKC100 clamp.
- Available in lengths of 40", 80", 120", 180", 240", and 360".

Fittings



This section offers a full selection of fittings and accessories to complete our strut system. Fittings are made from hot rolled, pickled and oiled plate or strip steel in accordance with ASTM A1018 33,000 PSI min. yield, unless noted.

Dimensions

The following dimensions apply to all fittings except as noted:

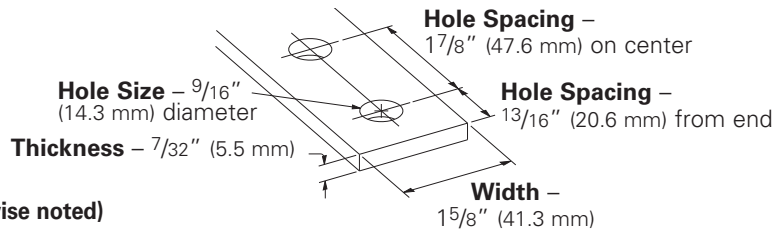

Materials & Finishes (Unless otherwise noted)

Finish Code	Finish	Specification
PLN	Plain	ASTM A1018 33,000 PSI min. yield
ZN	Electro-Plated Zinc	ASTM B633 SC3 Type III or ASTM A653
GRN	DURA GREEN™	
HDG	Hot-Dipped Galvanized	ASTM A123
SS4	Stainless Steel Type 304	ASTM A240
SS6	Stainless Steel Type 316	ASTM A240
AL	Aluminum	ASTM B209

Note: A minimum order may apply on special material and finishes.

Hardware

Nuts and bolts are not included with the fittings and must be ordered separately, unless noted.

Pre-Assembled Fittings

Some fittings are available with hex head cap screws and channel nuts pre-assembled.

These fittings and finishes will be flagged using the following symbol.



PA ^{ZN}
GRN

Metric

Metric dimensions are shown in parentheses. Unless noted, all metric dimensions are in millimeters.

Load Data

The load data published includes safety factor of 2.5 when used with 12 ga. (2.6) channel safety factor = ratio of ultimate load to the design load).

Use 1/2"-13 x 7/8" hex head cap screws and 1/2"-13 (N225 or TN225) channel nuts for the rated results.

Note: See page 277 Design Load Data for typical channel - fitting connections.

Recommended Bolt Torque

Bolt Size	1/4"-20	5/16"-18	3/8"-16	1/2"-13
ft·lbs	6	11	19	50
Nm	8	15	26	68

See chart on page 154 for setscrew torque.

4Dimension™ Strut System Compatible

These fittings and finishes will be flagged using the following symbol.



B200-B202-2

- Standard finishes: ZN, GRN, HDG, SS4, SS6, AL

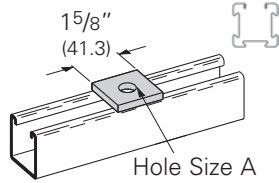

Square Washer

Part No.	A		Bolt Size		Wt./C	
	In.	mm	In.	mm	Lbs.	kg
B200	3/8"	(9.5)	5/16"	(7.9)	18	(8.1)
B201	7/16"	(11.1)	3/8"	(9.5)	18	(8.1)
B202	9/16"	(14.2)	1/2"	(12.7)	17	(7.7)
B202-1	11/16"	(17.4)	5/8"	(15.9)	16	(7.2)
B202-2	13/16"	(20.6)	3/4"	(19.0)	15	(6.8)
B202-3	15/16"	(23.8)	7/8"	(22.2)	14	(6.3)

B200D-B202-2D

- Standard finishes: ZN, GRN, HDG, SS4, SS6, AL

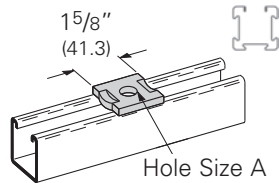

No Twist Square Washer

Part No.	A		Bolt Size		Wt./C	
	In.	mm	In.	mm	Lbs.	kg
B200D	3/8"	(9.5)	5/16"	(7.9)	18	(8.1)
B201D	7/16"	(11.1)	3/8"	(9.5)	18	(8.1)
B202D	9/16"	(14.2)	1/2"	(12.7)	17	(7.7)
B202-1D	11/16"	(17.4)	5/8"	(15.9)	16	(7.2)
B202-2D	13/16"	(20.6)	3/4"	(19.0)	15	(6.8)

B129

Two Hole Splice Plate

- Standard finishes: ZN, GRN
- Wt./C 37 Lbs. (16.8 kg)

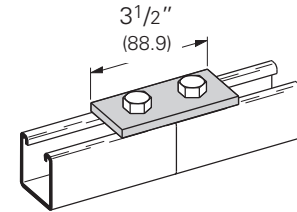

B340

Two Hole Splice Plate

- Standard finishes: ZN, GRN
- Wt./C 34 Lbs. (15.4 kg)

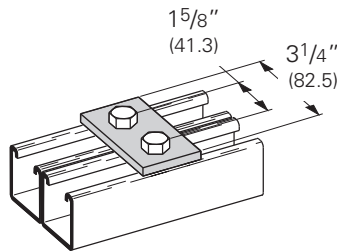

B528

Two Hole Splice Plate

- Standard finishes: ZN, GRN
- Wt./C 50 Lbs. (22.7 kg)

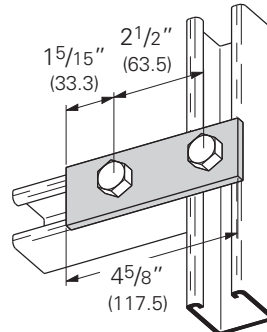

B141

Three Hole Splice Plate

- Standard finishes: ZN, GRN
- Wt./C 55 Lbs. (24.9 kg)

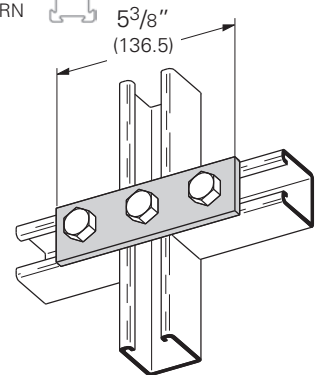

B557

Three Hole Splice Plate

- Standard finishes: ZN, GRN
- Wt./C 50 Lbs. (22.7 kg)

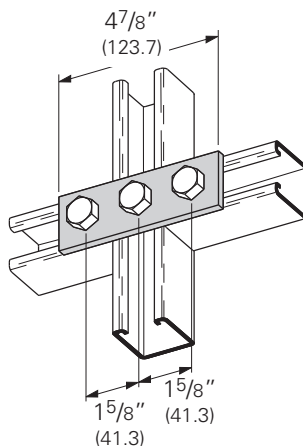

B341

Four Hole Splice Plate

- Standard finishes: ZN, GRN, HDG
- Wt./C 76 Lbs. (34.5 kg)

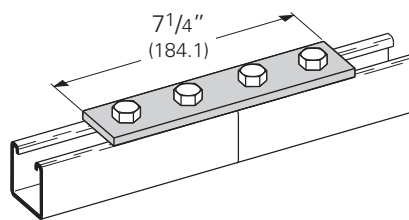

B342

Five Hole Splice Plate

- Standard finishes: ZN, GRN
- Wt./C 96 Lbs. (43.5 kg)

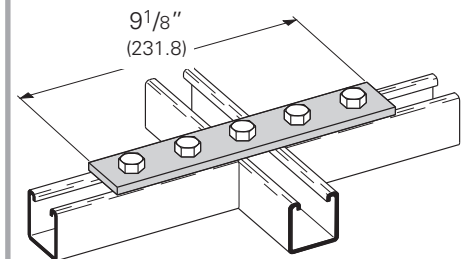

PA Pre-assembled fitting



4Dimension compatible fitting

Reference page 106 for general fitting and standard finish specifications.

Flat Plate Fittings

B138 Two Hole Swivel Plate

- Standard finishes: ZN, GRN
- Wt./C 48 Lbs. (21.8 kg)

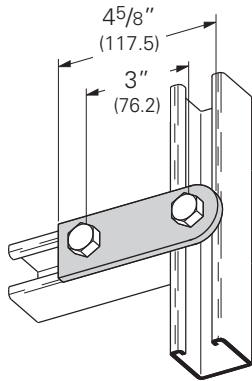

B139 Three Hole Swivel Plate

- Standard finishes: ZN, GRN
- Wt./C 69 Lbs. (31.3 kg)

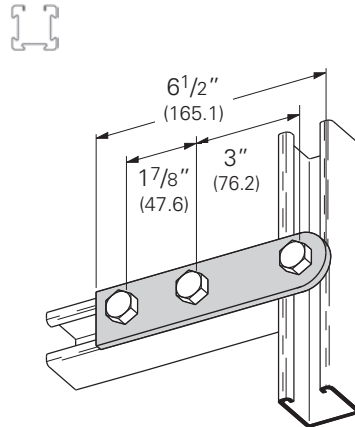

B504 Four Hole Splice Plate

- Standard finishes: ZN, GRN
- Wt./C 73 Lbs. (33.1 kg)

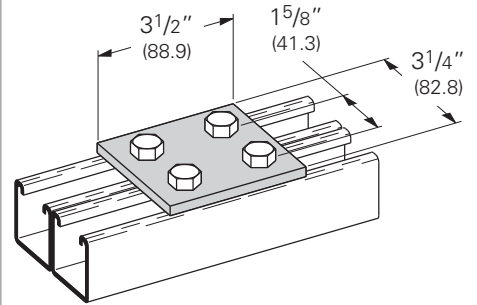

B140 Three Hole Corner Plate

- Standard finishes: ZN, GRN, HDG, SS4
- Wt./C 56 Lbs. (25.4 kg)

PA ZN
GRN

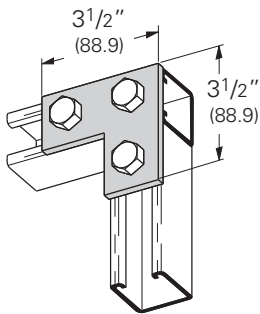

B143 Four Hole Corner Plate

- Standard finishes: ZN, GRN, HDG, SS4
- Wt./C 75 Lbs. (34.0 kg)

PA ZN
GRN

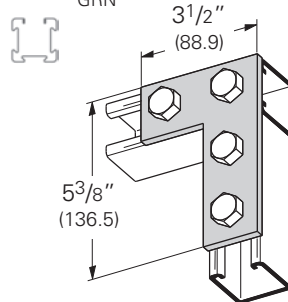

B133 Four Hole Tee Plate

- Standard finishes: ZN, GRN, HDG, SS4, AL
- Wt./C 75 Lbs. (34.0 kg)

PA ZN
GRN

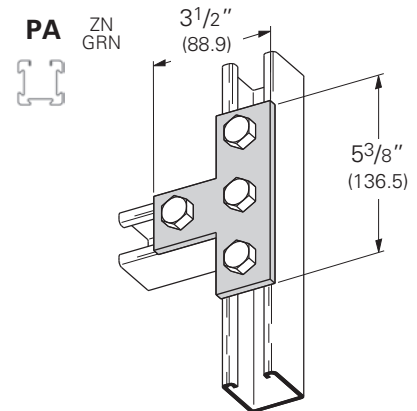

B132 Five Hole Cross Plate

- Standard finishes: ZN, GRN, HDG
- Wt./C 100 Lbs. (45.3 kg)

PA ZN
GRN

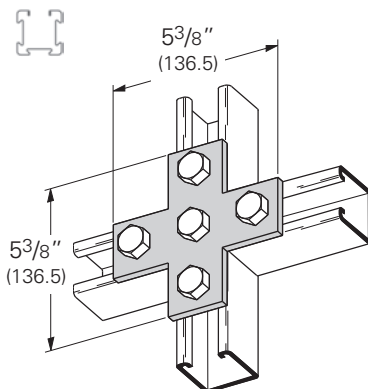

B135 Three Hole Corner Gusset Plate

- Standard finishes: ZN, GRN
- Wt./C 70 Lbs. (31.7 kg)

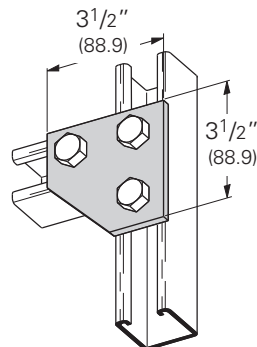

B142 Four Hole Corner Gusset Plate

- Standard finishes: ZN, GRN, HDG
- Wt./C 102 Lbs. (46.2 kg)

PA ZN
GRN

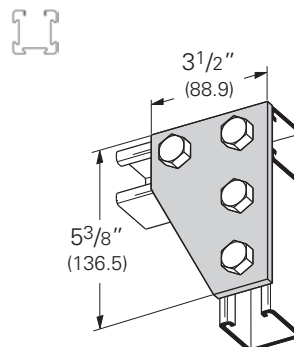

PA Pre-assembled fitting

 4Dimension compatible fitting

Reference page 106 for general fitting and standard finish specifications.

B137
Four Hole Corner Gusset Plate

- Standard finishes: ZN, GRN
- Wt./C 273 Lbs. (123.8 kg)

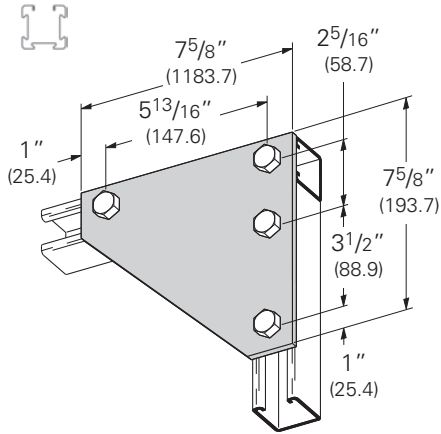

B556
Five Hole Corner Gusset Plate

- Standard finishes: ZN, GRN
- Wt./C 145 Lbs. (65.8 kg)

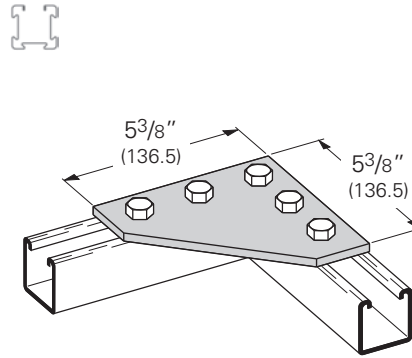

B337
Three Hole Tee Gusset Plate

- Standard finishes: ZN, GRN
- Wt./C 70 Lbs. (31.7 kg)

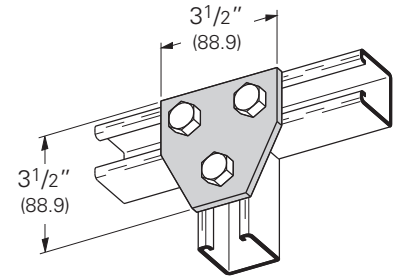

B432
Four Hole Tee Gusset Plate

- Standard finishes: ZN, GRN
- Wt./C 100 Lbs. (45.3 kg)

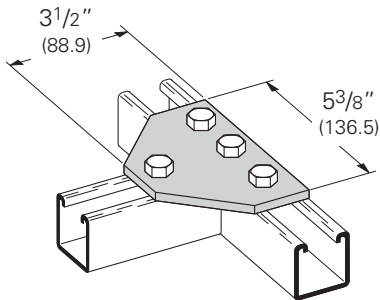

B136
Four Hole Tee Gusset Plate

- Standard finishes: ZN, GRN, HDG
- Wt./C 100 Lbs. (45.3 kg)

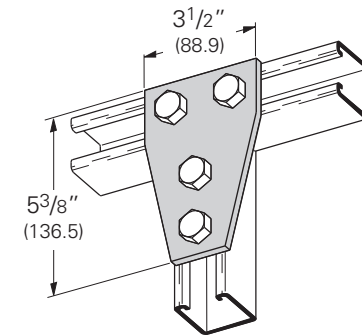

B532
Five Hole Tee Gusset Plate

- Standard finishes: ZN, GRN
- Wt./C 143 Lbs. (64.8 kg)

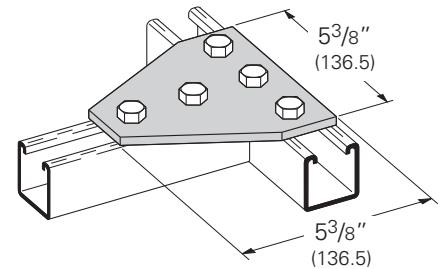

B339
Six Hole Tee Gusset Plate

- Standard finishes: ZN, GRN
- Wt./C 149 Lbs. (67.6 kg)

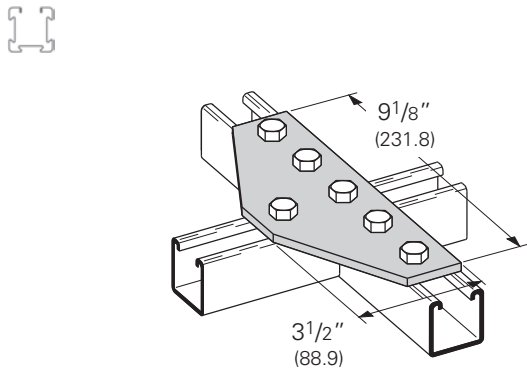

B334
Seven Hole Cross Gusset Plate

- Standard finishes: ZN, GRN
- Wt./C 232 Lbs. (105.2 kg)

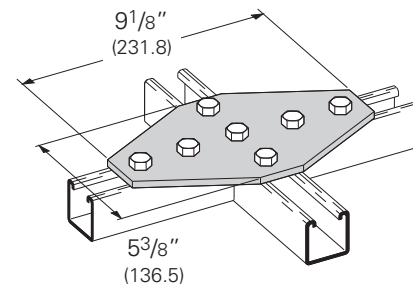

PA Pre-assembled fitting

 Dimension compatible fitting

Reference page 106 for general fitting and standard finish specifications.

90° Angle Fittings

B420-378 One Hole Corner Angle

- Standard finishes: ZN, GRN
- Wt./C 60 Lbs. (27.2 kg)

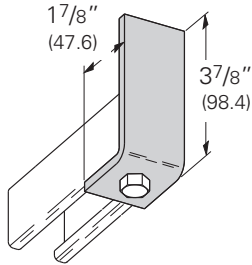

B420-578 One Hole Corner Angle

- Standard finishes: ZN, GRN
- Wt./C 85 Lbs. (38.5 kg)

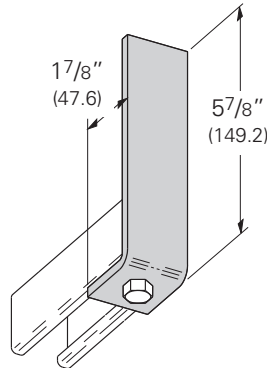

B420-778 One Hole Corner Angle

- Standard finishes: ZN, GRN
- Wt./C 107 Lbs. (48.5 kg)

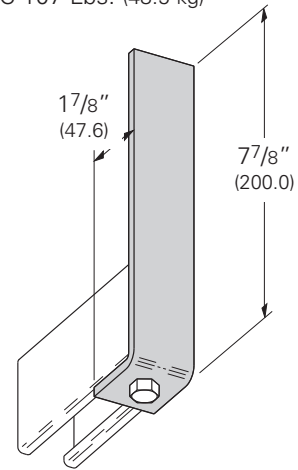

B420-978 One Hole Corner Angle

- Standard finishes: ZN, GRN
- Wt./C 129 Lbs. (58.5 kg)

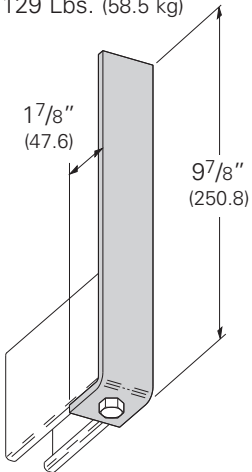

B101 Two Hole Corner Angle

- Standard finishes: ZN, GRN, HDG, SS4, AL
- Wt./C 37 Lbs. (16.8 kg)

PA ZN GRN

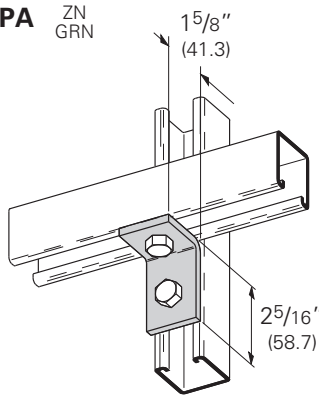

B230 Two Hole Corner Angle

- Standard finishes: ZN, GRN, HDG, SS4, AL
- Wt./C 37 Lbs. (16.8 kg)

PA ZN GRN

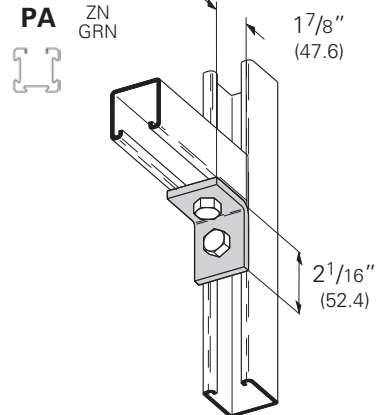

B231 Two Hole "No-Twist" Corner Angle

- Standard finishes: ZN, GRN, HDG
- Wt./C 41 Lbs. (18.6 kg)

PA ZN GRN

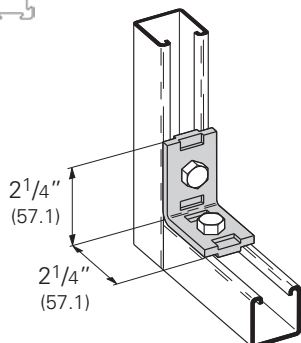

B359 Two Hole Corner Angle

- Standard finishes: ZN, GRN
- Wt./C 48 Lbs. (21.8 kg)

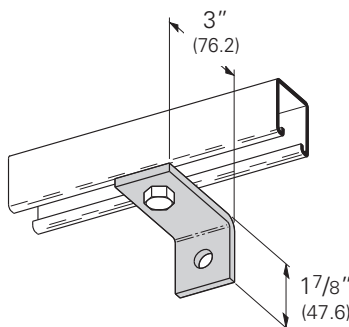

B360 Two Hole Corner Angle

- Standard finishes: ZN, GRN
- Wt./C 53 Lbs. (24.0 kg)

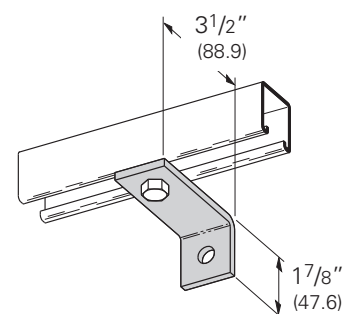

PA Pre-assembled fitting



4Dimension compatible fitting

Reference page 106 for general fitting and standard finish specifications.

B361 Two Hole Corner Angle

- Standard finishes: ZN, GRN
- Wt./C 60 Lbs. (27.2 kg)

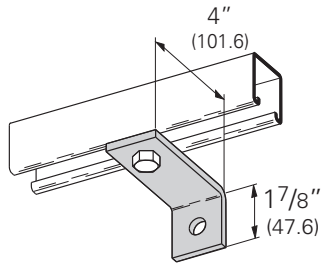

B102 Three Hole Corner Angle

- Standard finishes: ZN, GRN, HDG, SS4
- Wt./C 56 Lbs. (25.4 kg)

PA ZN GRN

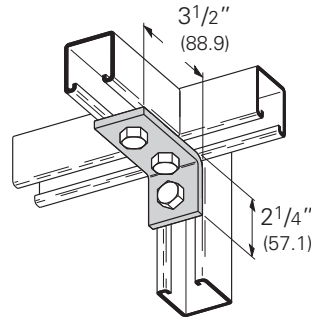

B103 Three Hole Corner Angle

- Standard finishes: ZN, GRN, HDG, SS4
- Wt./C 56 Lbs. (25.4 kg)

PA ZN GRN

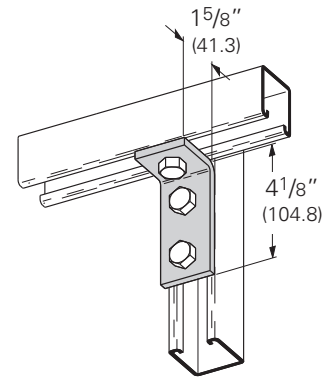

B232 Three Hole Corner Angle

- Standard finishes: ZN, GRN, HDG, SS4
- Wt./C 56 Lbs. (25.4 kg)

PA ZN GRN

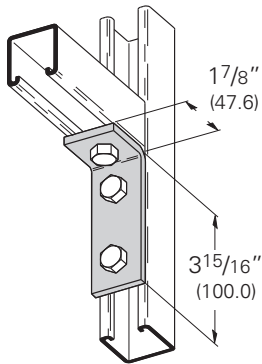

B374 Three Hole Corner Angle

- Standard finishes: ZN, GRN, HDG
- Wt./C 56 Lbs. (25.4 kg)

PA ZN GRN

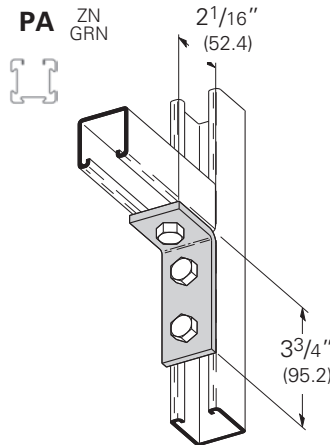

B529 Three Hole Corner Angle

- Standard finishes: ZN, GRN
- Wt./C 78 Lbs. (35.4 kg)

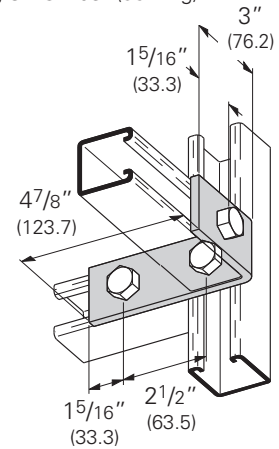

B104 Four Hole Corner Angle

- Standard finishes: ZN, GRN, HDG, SS4, SS6, AL
- Wt./C 78 Lbs. (35.4 kg)

PA ZN GRN

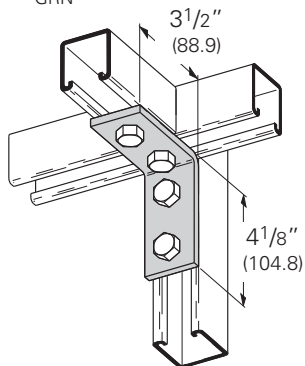

B115 Four Hole Corner Angle

- Standard finishes: ZN, GRN, HDG, SS4, AL
- Wt./C 76 Lbs. (34.5 kg)

PA ZN GRN

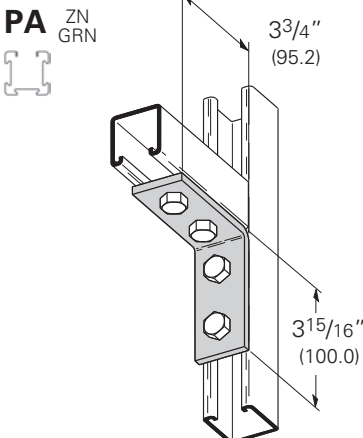

B558 Four Hole Corner Angle

- Standard finishes: ZN, GRN
- Wt./C 73 Lbs. (33.1 kg)

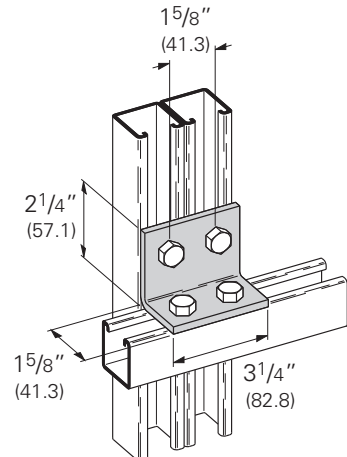

PA Pre-assembled fitting



4Dimension compatible fitting

Reference page 106 for general fitting and standard finish specifications.

90° Angle Fittings

B235R Three Hole (Right Hand) Offset Bent Angle

- $1\frac{5}{8}$ " (41.3) from center to center of the holes that are shown with bolt heads
- Standard finishes: ZN, GRN
- Wt./C 53 Lbs. (24.0 kg)

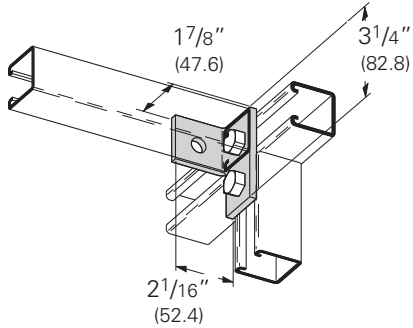

B235L Three Hole (Left Hand) Offset Bent Angle

- $1\frac{5}{8}$ " (41.3) from center to center of the holes that are shown with bolt heads
- Standard finishes: ZN, GRN
- Wt./C 53 Lbs. (24.0 kg)

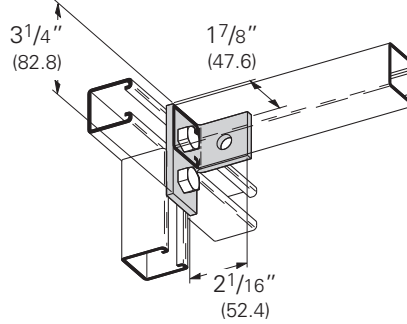

B236R Three Hole (Right Hand) Offset Bent Angle

- Standard finishes: ZN, GRN
- Wt./C 65 Lbs. (29.5 kg)

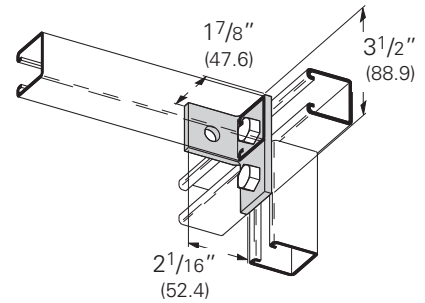

B236L Three Hole (Left Hand) Offset Bent Angle

- Standard finishes: ZN, GRN
- Wt./C 65 Lbs. (29.5 kg)

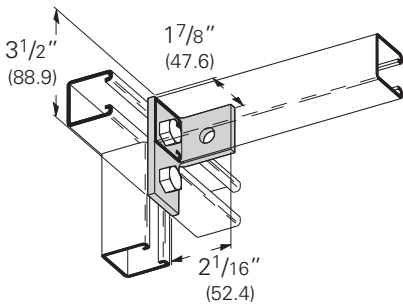

B237 Three Hole Offset Bent Tee

- Standard finishes: ZN, GRN
- Wt./C 71 Lbs. (32.2 kg)

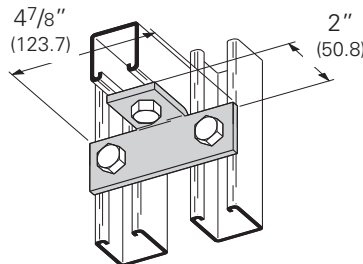

B357 Four Hole Offset Bent Tee

- Standard finishes: ZN, GRN
- Wt./C 77 Lbs. (34.9 kg)

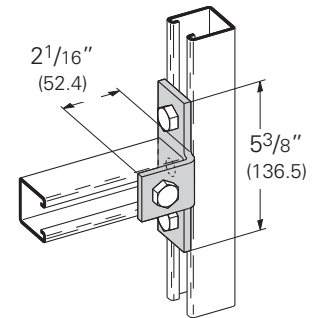

B238R Four Hole (Right Hand) Offset Bent Tee

- Standard finishes: ZN, GRN
- Wt./C 76 Lbs. (34.5 kg)

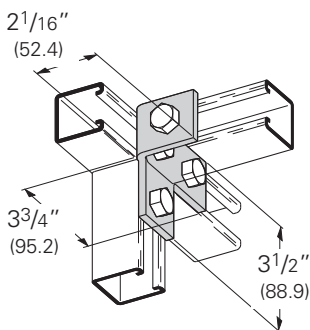

B238L Four Hole (Left Hand) Offset Bent Tee

- Standard finishes: ZN, GRN
- Wt./C 76 Lbs. (34.5 kg)

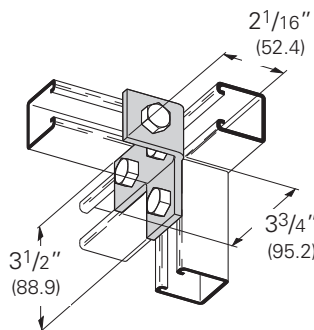

B239 Five Hole Offset Bent Tee

- Standard finishes: ZN, GRN
- Wt./C 96 Lbs. (43.5 kg)

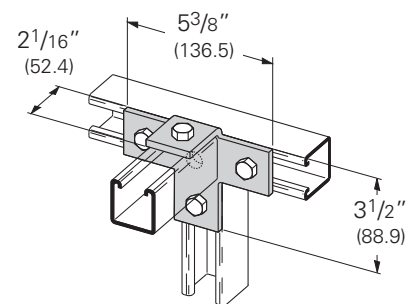

Reference page 106 for general fitting and standard finish specifications.

B844
Universal Shelf Bracket

- Standard finishes: ZN, GRN, HDG, SS4
- Wt./C 132 Lbs. (59.9 kg)

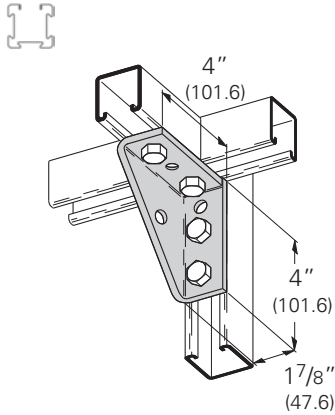

B844W
Universal Shelf Bracket - Welded

- Standard finishes: ZN, GRN
- Wt./C 134 Lbs. (60.8 kg)

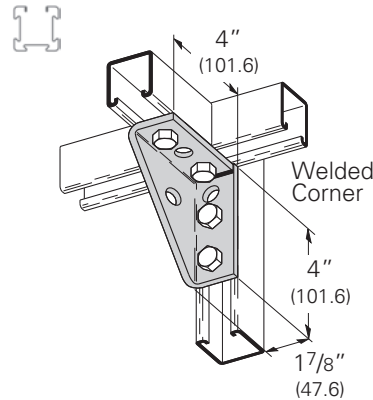

B888W
Universal Shelf Bracket - Welded

- Standard finishes: ZN, GRN
- Wt./C 197 Lbs. (89.4 kg)

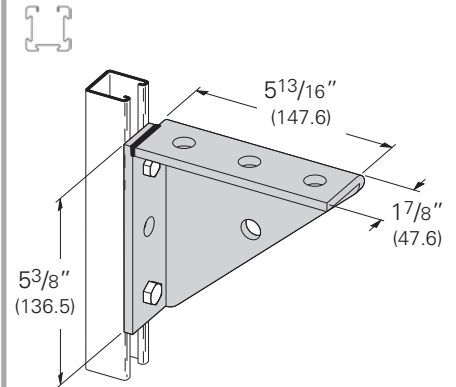

B234R
Four Hole (Right Hand) Corner Gusset

- Standard finishes: ZN, GRN, HDG
- Wt./C 100 Lbs. (45.3 kg)

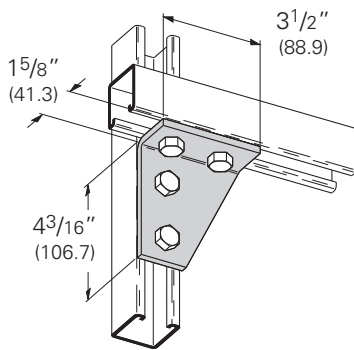

B234L
Four Hole (Left Hand) Corner Gusset

- Standard finishes: ZN, GRN, HDG
- Wt./C 100 Lbs. (45.3 kg)

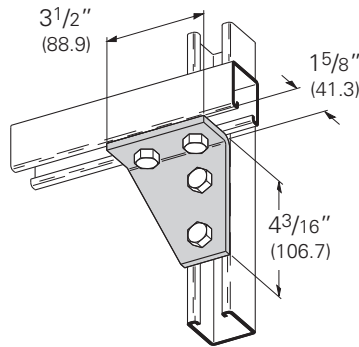

B134R
Four Hole (Right Hand) Corner Gusset

- Standard finishes: ZN, GRN
- Wt./C 100 Lbs. (45.3 kg)

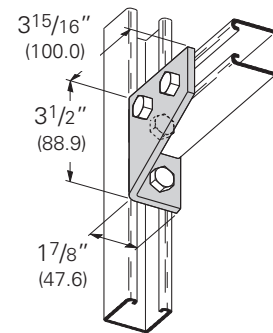

B134L
Four Hole (Left Hand) Corner Gusset

- Standard finishes: ZN, GRN
- Wt./C 100 Lbs. (45.3 kg)

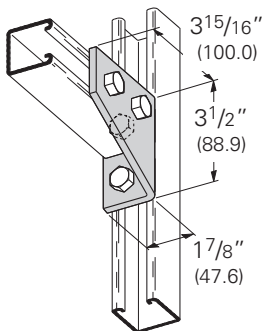

B125
Three Hole Gussetted Shelf Angle

- Standard finishes: ZN, GRN
- Wt./C 67 Lbs. (30.4 kg)

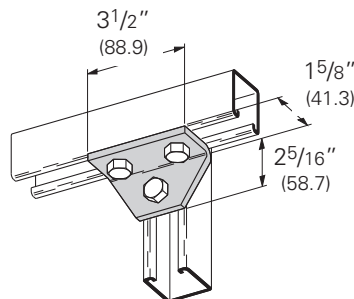

B118
Four Hole Gussetted Shelf Angle

- Standard finishes: ZN, GRN, HDG
- Wt./C 102 Lbs. (46.2 kg)

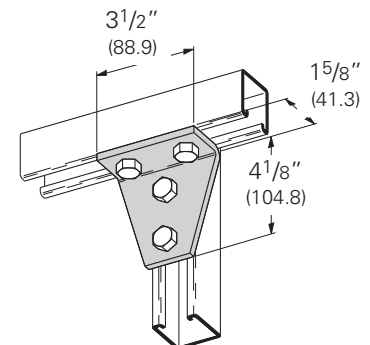

Reference page 106 for general fitting and standard finish specifications.

90° Angle Fittings

B485 Four Hole Gussetted Shelf Angle

- Standard finishes: ZN, GRN
- Wt./C 148 Lbs. (67.1 kg)

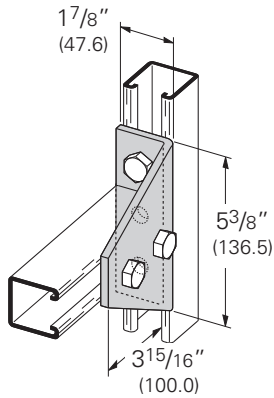

B533 Five Hole Gussetted Shelf Angle

- Standard finishes: ZN, GRN
- Wt./C 141 Lbs. (63.9 kg)

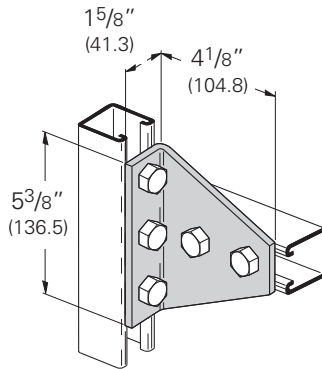

B126 Four Hole Gussetted Three Way Shelf Angle

- Standard finishes: ZN, GRN
- Wt./C 101 Lbs. (45.8 kg)

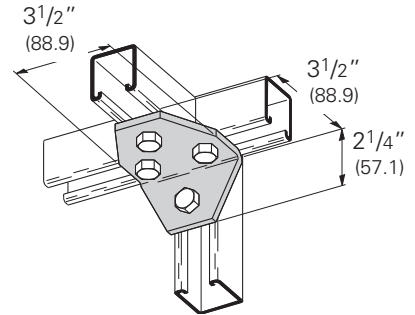

B127 Five Hole Gussetted Three Way Shelf Angle

- Standard finishes: ZN, GRN
- Wt./C 135 Lbs. (61.2 kg)

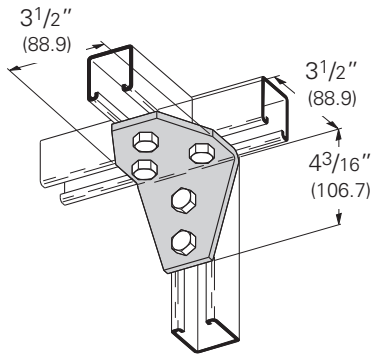

B503R Six Hole (Right Hand) Gussetted Corner Connection

- Standard finishes: ZN, GRN
- Wt./C 229 Lbs. (103.9 kg)

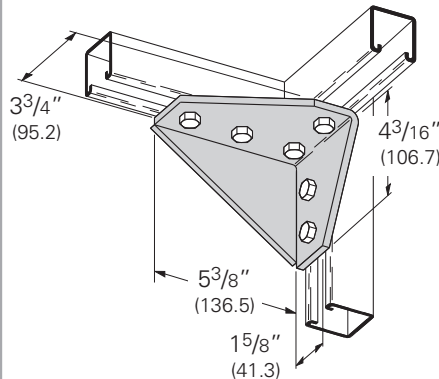

B503L Six Hole (Left Hand) Gussetted Corner Connection

- Standard finishes: ZN, GRN
- Wt./C 229 Lbs. (103.9 kg)

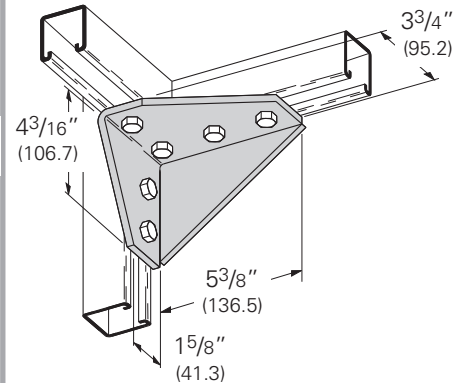

B663 Seven Hole Gussetted Corner Connection

- Standard finishes: ZN, GRN
- Wt./C 289 Lbs. (131.1 kg)

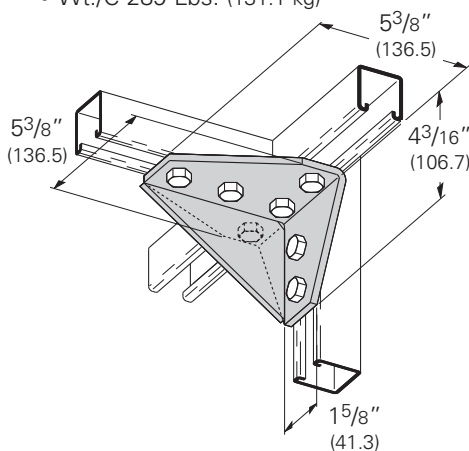

B371 Two Hole Adjustable Corner Angle

- Standard finishes: ZN, GRN
- Wt./C 41 Lbs. (18.6 kg)

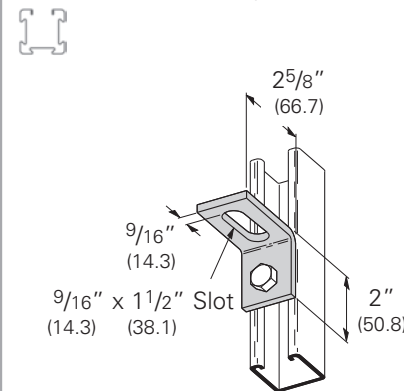

B372 Two Hole Adjustable Corner Angle

- Standard finishes: ZN, GRN
- Wt./C 38 Lbs. (17.2 kg)

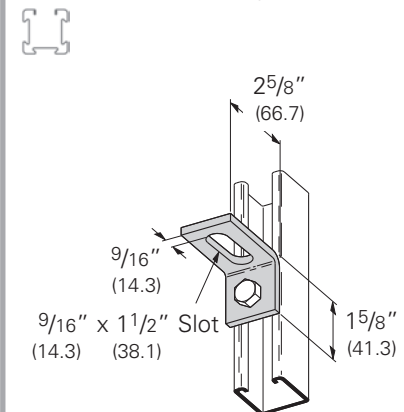

 4Dimension compatible fitting

Reference page 106 for general fitting and standard finish specifications.

B496
Two Hole Adjustable
Corner Angle

- Standard finishes: ZN, GRN
- Wt./C 85 Lbs. (38.5 kg)

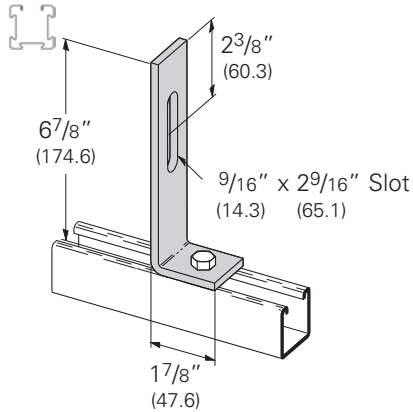

B496-1
Two Hole Adjustable
Corner Angle

- Standard finishes: ZN, GRN, HDG
- Wt./C 58 Lbs. (26.3 kg)

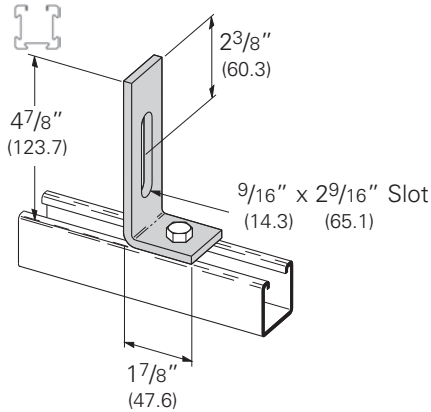

B371-2
Three Hole Adjustable
Corner Angle

- Standard finishes: ZN, GRN
- Wt./C 61 Lbs. (27.6 kg)

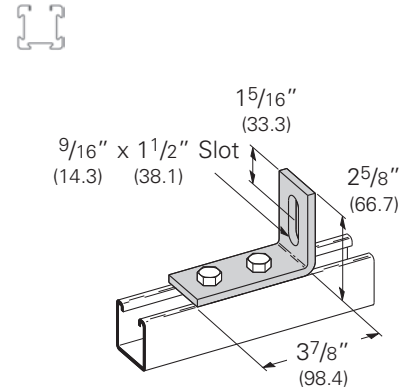

B104SH
Three Hole Adjustable
Corner Angle

- Standard finishes: ZN, GRN
- Wt./C 68 Lbs. (30.8 kg)

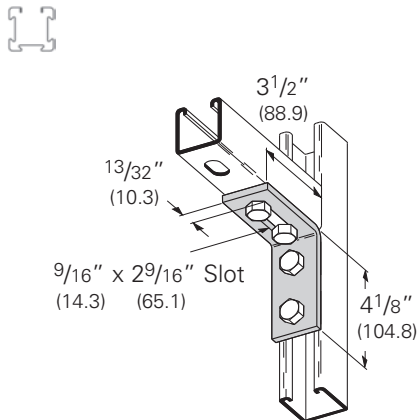

B461
Two Hole Adjustable
Corner Angle

- Standard finishes: ZN, GRN
- Wt./C 87 Lbs. (39.4 kg)

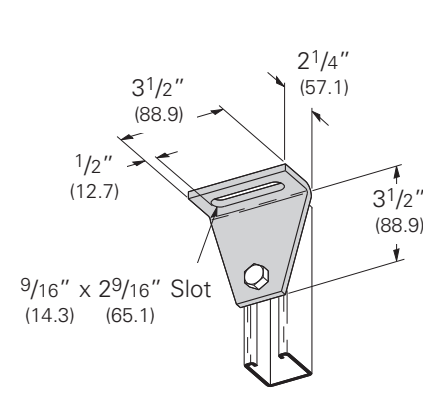

B112
Four Hole Adjustable
Corner Angle

- Standard finishes: ZN, GRN
- Wt./C 180 Lbs. (81.6 kg)

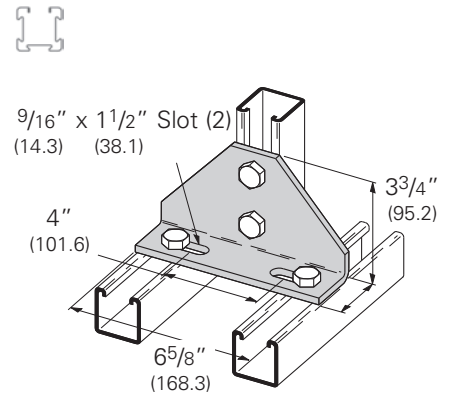

B113
Four Hole Adjustable
Corner Angle

- Standard finishes: ZN, GRN
- Wt./C 256 Lbs. (116.1 kg)

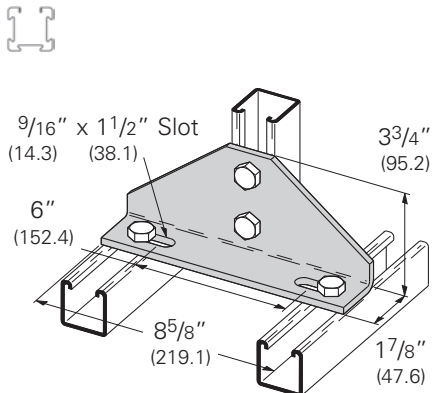

B109S
Two Hole Tapped
Corner Angle

- Standard finishes: ZN, GRN
- Wt./C 33 Lbs. (14.9 kg)

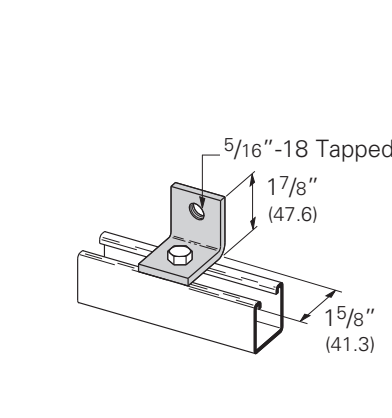

B521
Two Hole Bus Duct
Angle

- Standard finishes: ZN, GRN
- Wt./C 37 Lbs. (16.8 kg)

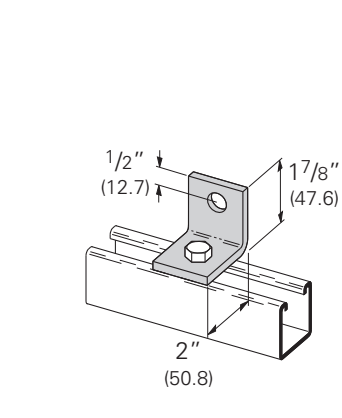

Reference page 106 for general fitting and standard finish specifications.

Angular Fittings

B147-B152 Two Hole Open Angle

- Standard finishes: ZN, GRN



Part No.	A	Wt./C	
		Lbs.	kg
B147	82 ¹ / ₂ °	63	(28.6)
B148	75°		
B149	67 ¹ / ₂ °		
B150	60°		
B151	52 ¹ / ₂ °		
B152	37 ¹ / ₂ °		

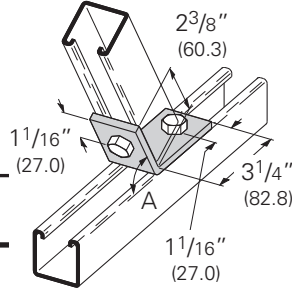

B243-B253 Four Hole Open Angle

- Standard finishes: ZN, GRN



Part No.	A	Wt./C	
		Lbs.	kg
B243	71 ¹ / ₂ °	77	(34.9)
B244	15°		
B245	22 ¹ / ₂ °		
B246	30°		
B247	37 ¹ / ₂ °		
B248	45°		
B249	52 ¹ / ₂ °		
B250	60°		
B251	67 ¹ / ₂ °		
B252	75°		
B253	82 ¹ / ₂ °		

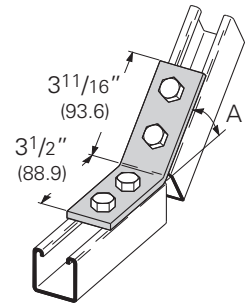

B162-B165 Two Hole Open Angle

- Standard finishes: ZN, GRN



Part No.	A	Wt./C	
		Lbs.	kg
B162	30°	59	(26.7)
B163	22 ¹ / ₂ °		
B164	15°		
B165	7 ¹ / ₂ °		

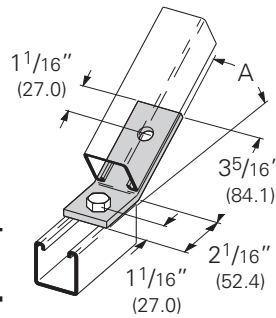

B322-B332 Two Hole Open Short Angle

- Standard finishes: ZN, GRN



Part No.	A	Wt./C	
		Lbs.	kg
B322	71 ¹ / ₂ °	35	(15.9)
B323	15°		
B324	22 ¹ / ₂ °		
B325	30°		
B326	37 ¹ / ₂ °		
B327	45°		
B328	52 ¹ / ₂ °		
B329	60°		
B330	67 ¹ / ₂ °		
B331	75°		
B332	82 ¹ / ₂ °		

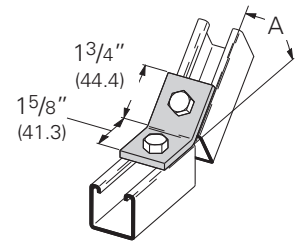

B154 Two Hole Open Angle

- Standard finishes: ZN, GRN, SS4
- Wt./C 58 Lbs. (26.3 kg)

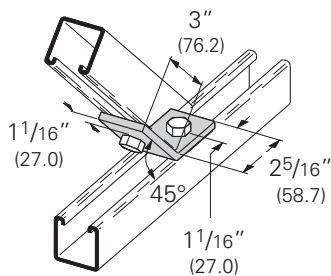

B522 Three Hole 95° Open Angle Fitting

- Standard finishes: ZN, GRN
- Wt./C 54 Lbs. (24.5 kg)

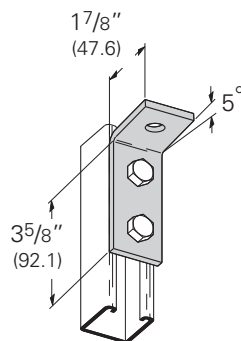

B488 Two Hole Leg Connection

- Standard finishes: ZN, GRN
- Wt./C 100 Lbs. (45.3 kg)

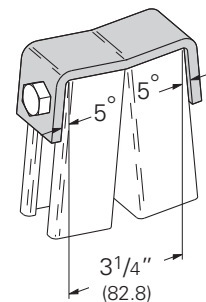

4Dimension compatible fitting

Reference page 106 for general fitting and standard finish specifications.

B156 - B161 Two Hole Closed Angle

- Standard finishes: ZN, GRN



Part No.	A	Wt./C	
		Lbs.	kg
B156	82 ¹ / ₂ °	56	(25.4)
B157	75°		
B158	67 ¹ / ₂ °		
B159	60°		
B160	52 ¹ / ₂ °		
B161	37 ¹ / ₂ °		

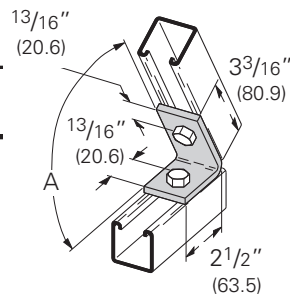

B155 Two Hole Closed Angle

- Standard finishes: ZN, GRN, HDG, SS4
- Wt./C 63 Lbs. (28.6 kg)

PA ^{ZN}_{GRN}

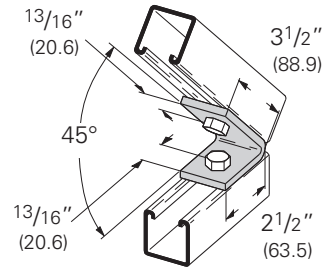

B363 - B369 Four Hole Closed Angle

- Standard finishes: ZN, GRN



Part No.	A	Wt./C	
		Lbs.	kg
B363	82 ¹ / ₂ °	95	(43.1)
B364	75°		
B365	67 ¹ / ₂ °		
B366	60°		
B367	52 ¹ / ₂ °		
B368	45°		
B369	37 ¹ / ₂ °		

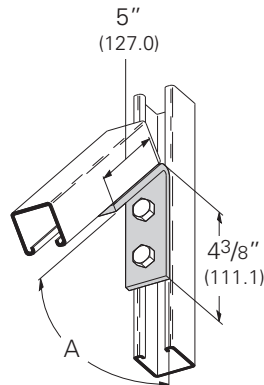

B335-2 SERIES Three Hole Adjustable Hinge

- Standard finishes: ZN, GRN



H
Hole Size
This Hole Only

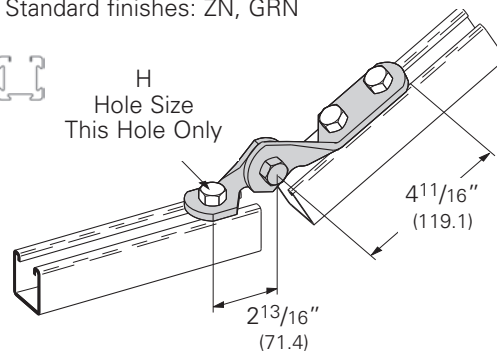

Part No. & Size	Hole Size H		Wt./C	
	In.	mm	Lbs.	kg
B335-2-3/8	7/16"	(11.1)	96	(43.2)
B335-2-1/2	9/16"	(14.3)	94	(42.3)
B335-2-5/8	11/16"	(17.4)	92	(41.4)
B335-2-3/4	13/16"	(20.6)	90	(40.5)

B335 Four Hole Adjustable Hinge

- Standard finishes: ZN, GRN
- Wt./C 110 Lbs. (49.9 kg)

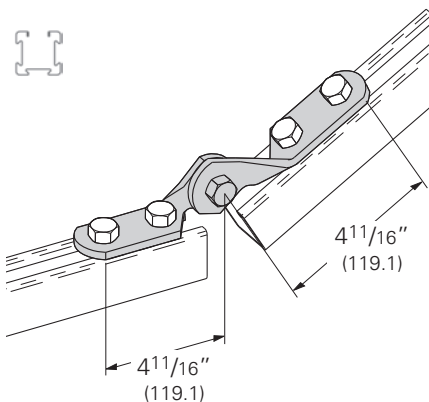

B335V Three Hole Half Hinge

- Standard finishes: ZN, GRN



Part No. & Size	Hole Size H		Wt./C	
	In.	mm	Lbs.	kg
B335V-1/2	9/16"	(14.3)	53	(24.1)
B335V-5/8	11/16"	(17.4)	54	(24.5)
B335V-3/4	13/16"	(20.6)	55	(24.9)

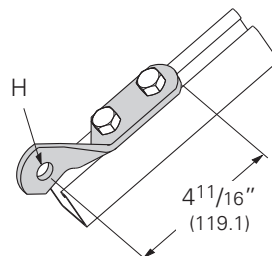

B335-1 Two Hole Adjustable Hinge

- Standard finishes: ZN, GRN
- Wt./C 78 Lbs. (35.4 kg)

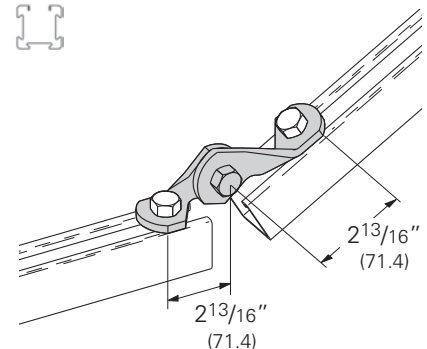

PA Pre-assembled fitting Dimension compatible fitting

Reference page 106 for general fitting and standard finish specifications.

Angular Fittings

B634 Single Channel Adjustable Brace

- Standard finishes: ZN, GRN
- Wt./C 306 Lbs. (138.8 kg)

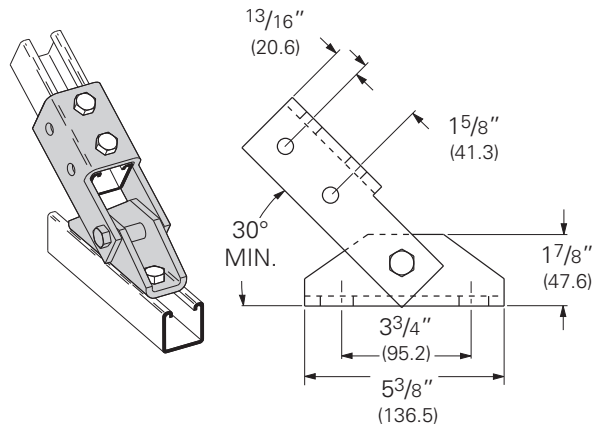

B635 Double Channel Adjustable Brace

- Standard finishes: ZN, GRN
- Wt./C 518 Lbs. (234.9 kg)

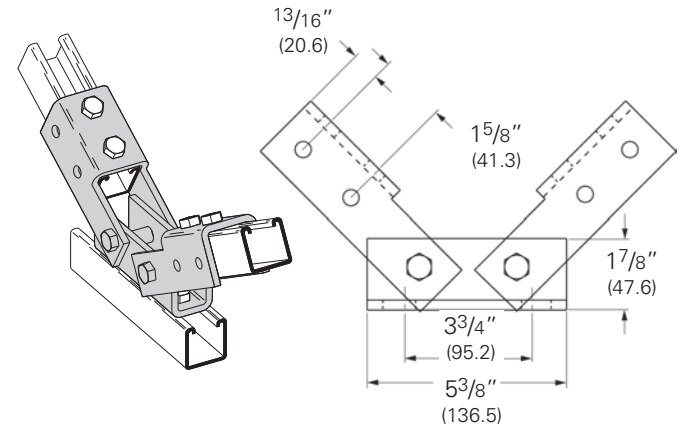

B650 SERIES Seismic Retrofit Bracket

- Available for 3/8", 1/2", 5/8", and 3/4" threaded rods.
- Allows installer to easily brace existing trapeze supports.
- Includes: Bracket, B129 plate, & key. Hardware sold separately.
- Standard finish: ZN, GRN

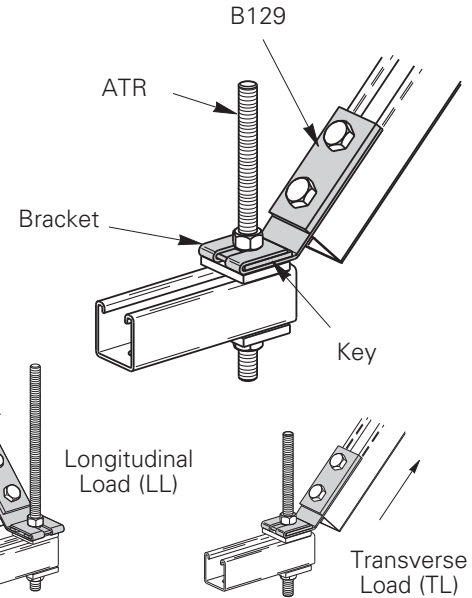
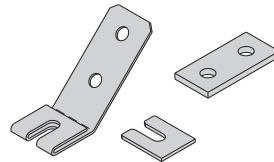

Part No. & Size	For Rod Size	TL		LL		Wt./C	
		Lbs.	kN	Lbs.	kN	Lbs.	kg
B650-3/8	3/8"	1100	(4.89)	1100	(4.89)	92	(41.4)
B650-1/2	1/2"	1500	(6.67)	1500	(6.67)	97	(43.6)
B650-5/8	5/8"	1500	(6.67)	1500	(6.67)	95	(42.7)
B650-3/4	3/4"	1500	(6.67)	1500	(6.67)	107	(48.5)

B633 Adjustable Seismic Hinge Fitting

- Use 1/2" Bolt & Channel Nut on two hole side of Connector Fitting (Torque to 50 ft.-lbs.)
- Allows for swivel in two planes.
- Standard finish: ZN

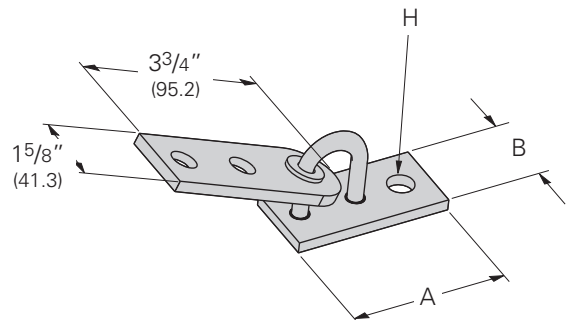

Part No. & Size	A		B		Hole Size H		Wt./C	
	In.	mm	In.	mm	In.	mm	Lbs.	kg
B633-1/2	3 1/2"	(82.5)	1 5/8"	(41.3)	9/16"	(14.3)	92	(41.4)
B633-5/8	3 1/2"	(82.5)	1 5/8"	(41.3)	1 1/16"	(17.4)	97	(43.6)
B633-3/4	3 1/2"	(82.5)	1 5/8"	(41.3)	1 3/16"	(20.6)	95	(42.7)
B633-7/8	3 9/16"	(90.5)	2"	(50.8)	1 5/16"	(23.8)	107	(48.5)
B633-1	3 9/16"	(90.5)	2"	(50.8)	1 1/16"	(27.0)	120	(54.0)
B633-1 1/8	3 9/16"	(90.5)	2"	(50.8)	1 3/16"	(30.2)	104	(47.2)
B633-1 1/4	3 7/8"	(98.4)	2 1/4"	(57.1)	1 5/16"	(33.3)	114	(51.7)

4Dimension compatible fitting

Reference page 106 for general fitting and standard finish specifications.

Miscellaneous Seismic Fittings

**Fig. 75
Swivel Attachment**

See page 89 for product information

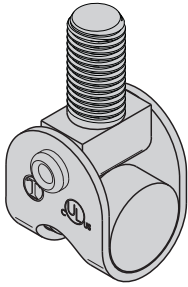

**SC228
Hanger Rod Stiffener**

See page 91 for product information

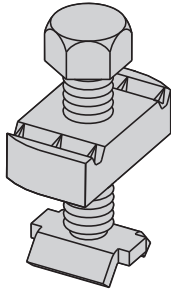

**Fig. 98
Rod Stiffener**

See page 91 for product information

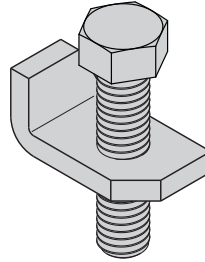

**Fig. 98B
Rod Stiffener with
Break-Off Bolt Head**

See page 91 for product information

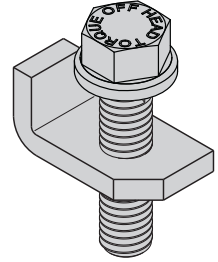

**Fig. 69
Retaining Strap**

See page 156 for product information

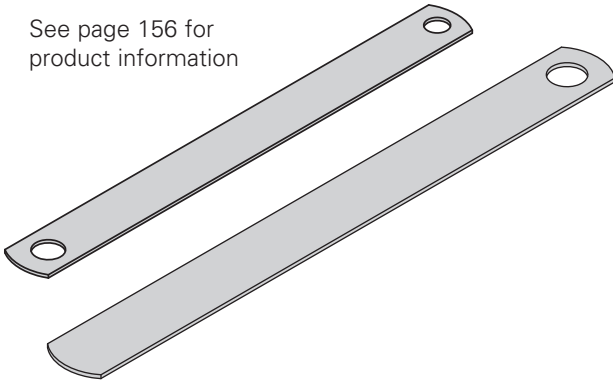

**Fig. 69R
Retrofit Retaining Strap**

See page 156 for product information

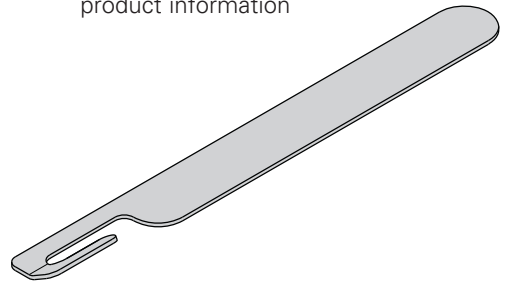

**Fig. 65
Reversible Steel C-Type
Beam Clamp - 3/4" (19.0mm)
Throat Opening**

See page 157 for product information

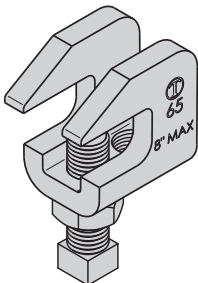

**Fig. 65XT
Reversible C-Type
Beam Clamp**

See page 157 for product information

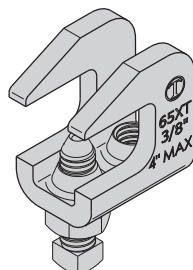

**Fig. 66
Reversible Steel C-Type
Beam Clamp - 1 1/4" (31.7mm)
Throat Opening**

See page 157 for product information

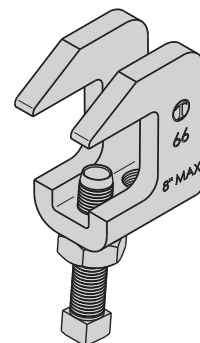

Reference page 106 for general fitting and standard finish specifications.

Miscellaneous Seismic Fittings

TOLCO™ Fig. 825 - Bar Joist Sway Brace Attachment

Size Range: One size accommodates all Fig. 900 Series sway brace attachments. Maximum Horizontal Design Load 2015 lbs (8.96kN).

Material: Steel

Function: To attach sway bracing and hanger assemblies to steel open web structural members.

Features: This product's design incorporates a concentric attachment point which is critical to the performance of structural seismic connections. NFPA 13 indicates the importance of concentric loading of connections and fasteners. Permits secure non-friction connection without drilling or welding. Unique design reinforces point of connection to joist. Break off head set screw design assures verification of proper installation torque (min. 31 ft.-lbs.).

Approvals: Underwriters Laboratories Listed in the USA (UL) and Canada (cUL). Approved by Factory Mutual Engineering (FM).

Installation Instructions: Fig. 825 is the structural attachment component of a longitudinal or lateral sway brace assembly. It is intended to be combined with a TOLCO transitional attachment, "bracing pipe" and a TOLCO "braced pipe" attachment, to form a complete bracing assembly. NFPA 13 and/or OSHPD guidelines should be followed.

To Install: Place the Fig. 825 on the steel beam, tighten the cone point set screws until heads break off. Attach other TOLCO transitional attachment fitting, Fig. 909, 910, 980 or 986. Transitional fitting attachment can pivot for adjustment to proper brace angle.

Finish: Plain, Electro-Galvanized and HDG

Approx. Wt./100: 247.5 Lbs. (112.2kg)

Order By: Figure number and finish
US Patent #6,098,942,
Canada Patent #2,286,659

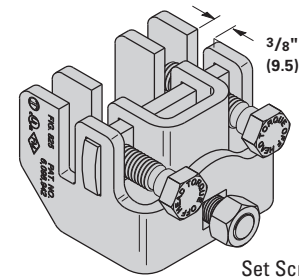

Set Screws & Hardware Included

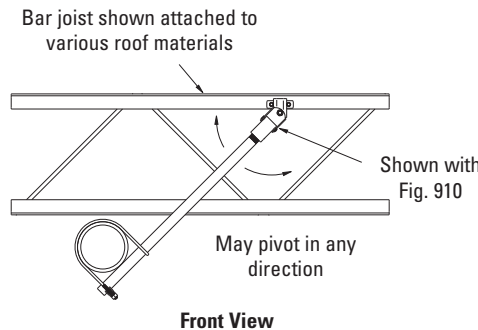
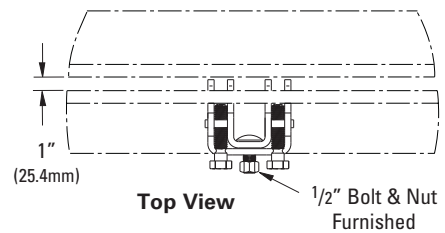

Front View

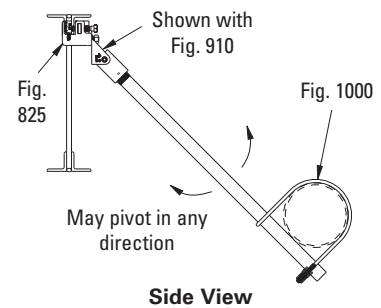

Side View

Max. Horizontal Design Load (UL)
2015 lbs. (8.96kN)
UL Listed as Hanger Attachment for
6" (150mm) Pipe at Maximum Spacing

		Max. Horizontal Design Loads (FM)			
		30°-44°	45°-59°	60°-74°	75°-90°
		lbs. / (kN)	lbs. / (kN)	lbs. / (kN)	lbs. / (kN)
Maximum	Perpendicular to	990	1360	1670	1860
3/8" Thick Flange	Structural Member	(4.40)	(6.05)	(7.43)	(8.27)
Maximum	Parallel to	460	630	770	860
3/8" Thick Flange	Structural Member	(2.04)	(2.80)	(3.42)	(3.82)

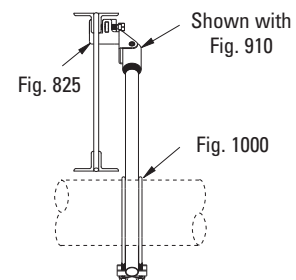

Eaton's B-Line series seismic bracing components are designed to be compatible only with other B-Line series bracing components, resulting in a listed seismic bracing assembly. Eaton B-Line Division warranty for seismic bracing components will be the warranty provided in Eaton B-Line Division standard terms and conditions of sale made available by Eaton, except that, in addition to the other exclusions from Eaton B-Line Division warranty, Eaton makes no warranty relating to B-Line series seismic bracing components that are combined with products not provided by Eaton.

Reference page 106 for general fitting and standard finish specifications.

TOLCO™ Fig. 825A - Bar Joist Sway Brace Attachment

Size Range: One size accommodates all Fig. 900 Series sway brace attachments. Maximum Horizontal Design Load 1600 lbs (7.11kN).

Material: Steel

Function: To attach sway bracing to steel open web structural members.

Features: This product's design incorporates a concentric attachment point which is critical to the performance of structural seismic connections. NFPA 13 indicates the importance of concentric loading of connections and fasteners. Permits secure non-friction connection without drilling or welding. Unique design reinforces point of connection to joist. Break off head bolt design assures verification of proper installation.

Approvals: Underwriters Laboratories Listed in the USA (**UL**) and Canada (**cUL**). For additional load, spacing and placement information relating to OSHPD projects, please refer to the TOLCO Seismic Restraint Systems Guidelines.

Installation Instructions: Fig. 825A is the structural attachment component of a longitudinal or lateral sway brace assembly. It is intended to be combined with a TOLCO transitional attachment, "bracing pipe" and a TOLCO "braced pipe" attachment to form a complete bracing assembly. NFPA 13 and/or OSHPD guidelines should be followed.

To Install: Place the Fig. 825A on the steel beam, tighten the cone point set screws until heads break off. Attach other TOLCO transitional attachment fitting, Fig. 909, 910, 980 or 986. Transitional fitting attachment can pivot for adjustment to proper brace angle.

Finish: Plain or Electro-Galvanized

Approx. Wt./100: 154.5 Lbs. (70.1kg)

Order By: Figure number and finish

Patent #6,098,942



Set Screws & Hardware Included

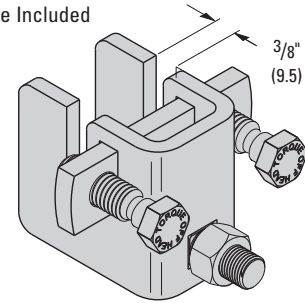

**Maximum Design Load
1600 lbs.**

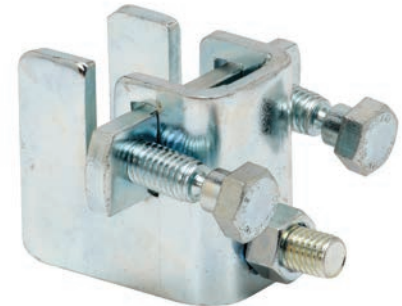

Bar joist shown attached to various roof materials

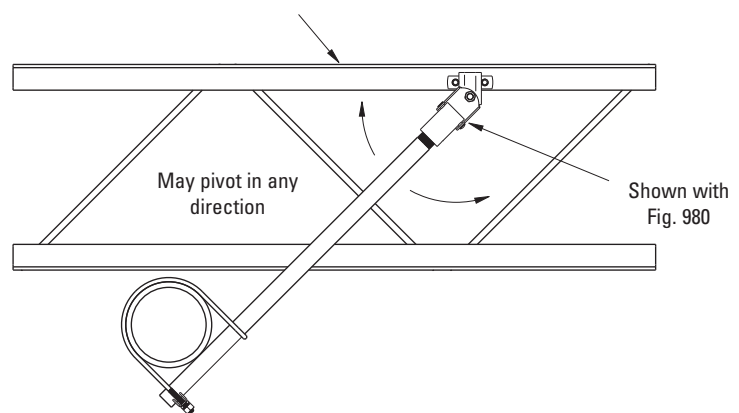

Eaton's B-Line series seismic bracing components are designed to be compatible only with other B-Line series bracing components, resulting in a listed seismic bracing assembly. Eaton B-Line Division warranty for seismic bracing components will be the warranty provided in Eaton B-Line Division standard terms and conditions of sale made available by Eaton, except that, in addition to the other exclusions from Eaton B-Line Division warranty, Eaton makes no warranty relating to B-Line series seismic bracing components that are combined with products not provided by Eaton.

Reference page 106 for general fitting and standard finish specifications.

Miscellaneous Seismic Fittings

TOLCO™ Fig. 828 - Universal Sway Brace Attachment

Size Range: One size accommodates all Fig. 900 Series sway brace attachments. Fits from 3/8" (9.4mm) to 7/8" (22.2mm) thick steel structure. For thicknesses less than 3/8" (9.4mm) refer to Fig. 825 and Fig. 825A.

Material: Steel

Function: To attach sway bracing to various types of steel structural members.

Features: Permits secure non-friction connection without drilling or welding. Unique design allows offset placement on wide flange beam, I-beam, C-channel, open web, welded steel trusses, etc.. Secures brace to structure either across or along the beam. Break-off set screws allow for visual verification of proper installation torque.

Approvals: Underwriters Laboratories Listed in the USA (UL) and Canada (cUL). Factory Mutual Approved (FM).

Installation Instructions: The Fig. 828 is the structural attachment component of a longitudinal or lateral sway brace assembly. It is intended to be combined with a TOLCO transitional attachment, "bracing pipe" and a TOLCO "braced pipe" attachment to form a complete bracing assembly. NFPA 13 and/or OSHPD guidelines should be followed.

To Install: Place the Fig. 828 on the flange of the beam, truss, or girder. Be sure the attachment is fully engaged to the rear of the opening. Tighten the cone point set screws (A) until the heads break off. Tighten the cone point set screw (B) until the head breaks off. Remove the flange nut from set screw (B). Install a TOLCO swivel fitting (Fig. 909, 910, 980, 986). Use flange nut to secure the swivel fitting.

Finish: Plain or Electro-Galvanized

Approx. Weight/100: 275 Lbs. (124.7kg)

Order By: Figure number and finish

Patent #6,098,942, #8,534,625

Canada Patent #2,286,659

Patent Pending

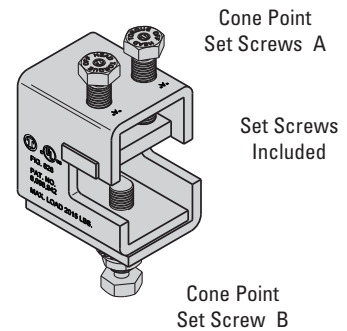

UL Horizontal Design Load
Maximum Design Load Across Beam
2015 lbs. (8.96kN)
Maximum Design Load Along Beam
2015 lbs. (8.96kN)

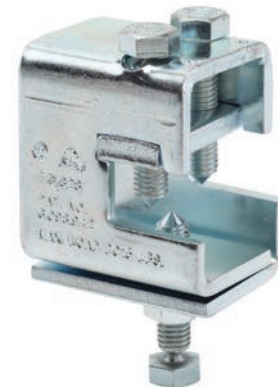

Max. Horizontal Design Load (FM)				
With Brace Perpendicular To The Beam				
Brace Angle (degrees from vertical)				
30°-44°	45°-59°	60°-74°	75°-90°	
1570	2220	1210	700	
(6.98kN)	(9.87kN)	(5.38kN)	(3.11kN)	

Max. Horizontal Design Load (FM)				
With Brace Parallel To The Beam				
Brace Angle (degrees from vertical)				
30°-44°	45°-59°	60°-74°	75°-90°	
690	970	1210	1330	
(3.07kN)	(4.31kN)	(5.38kN)	(5.91kN)	

FM Approved design loads are based on ASD design method.

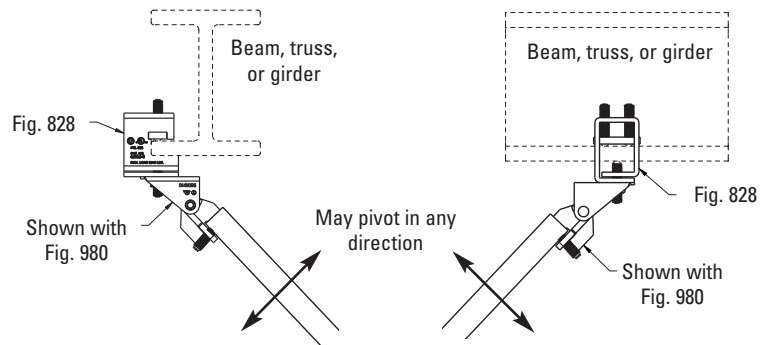

Eaton's B-Line series seismic bracing components are designed to be compatible only with other B-Line series bracing components, resulting in a listed seismic bracing assembly. Eaton B-Line Division warranty for seismic bracing components will be the warranty provided in Eaton B-Line Division standard terms and conditions of sale made available by Eaton, except that, in addition to the other exclusions from Eaton B-Line Division warranty, Eaton makes no warranty relating to B-Line series seismic bracing components that are combined with products not provided by Eaton.

TOLCO™ Fig. 980 - Universal Swivel Sway Brace Attachment - 3/8"-16 to 3/4"-10 rods

TOLCO™ Fig. 980H - Universal Swivel Sway Brace Attachment - 7/8"-9 to 1 1/4"-7 rods

Size Range: One size fits bracing pipe 1" (25mm) thru 2" (50mm), 12 gauge (2.6mm) channel, and all structural steel up to 1/4" (31.7mm) thick.

Material: Steel. Stainless Steel Type 316 (SS6) optional.

Function: Multi-functional attachment to structure or braced pipe fitting.

Features: This product's design incorporates a concentric attachment opening which is critical to the performance of structural seismic connections. NFPA 13 (2010) 9.3.5.8.4 indicates clearly that fastener table load values are based only on concentric loading. Mounts to any surface angle. Break off bolt head assures verification of proper installation.

Installation: Fig.980 is the structural or transitional attachment component of a longitudinal or lateral sway brace assembly. It is intended to be combined with the "bracing pipe" and TOLCO "braced pipe" attachment, Fig. 1000, 1001, 2002, 4L, 4A or 4B to form a complete bracing assembly. NFPA 13 and/or OSHPD guidelines should be followed.

To Install: Place the Fig. 980 onto the "bracing pipe". Tighten the set screw until the head breaks off. Attachment can pivot for adjustment to proper brace angle.

Approvals: —Underwriters Laboratories Listed in the USA (UL) and Canada (cUL). Approved by Factory Mutual Engineering (FM).

Note: Fig. 980 Swivel Attachment and Fig. 1001, Fig. 1000, Fig. 2002, Fig. 4A, Fig. 4B or Fig. 4L pipe clamps make up a sway brace system of UL Listed attachments and bracing materials which satisfies the requirements of Underwriters Laboratories and the National Fire Protection Association (NFPA)

Finish: Plain, Electro-Galvanized or Stainless Steel. Contact customer service for alternative finishes.

Order By: Figure number and finish.

US Patent Numbers

Pat. #6,273,372, Pat. #6,517,030, Pat. #6,953,174,
Pat. #6,708,930, Pat. #7,191,987, Pat. #7,441,730, Pat. #7,669,806

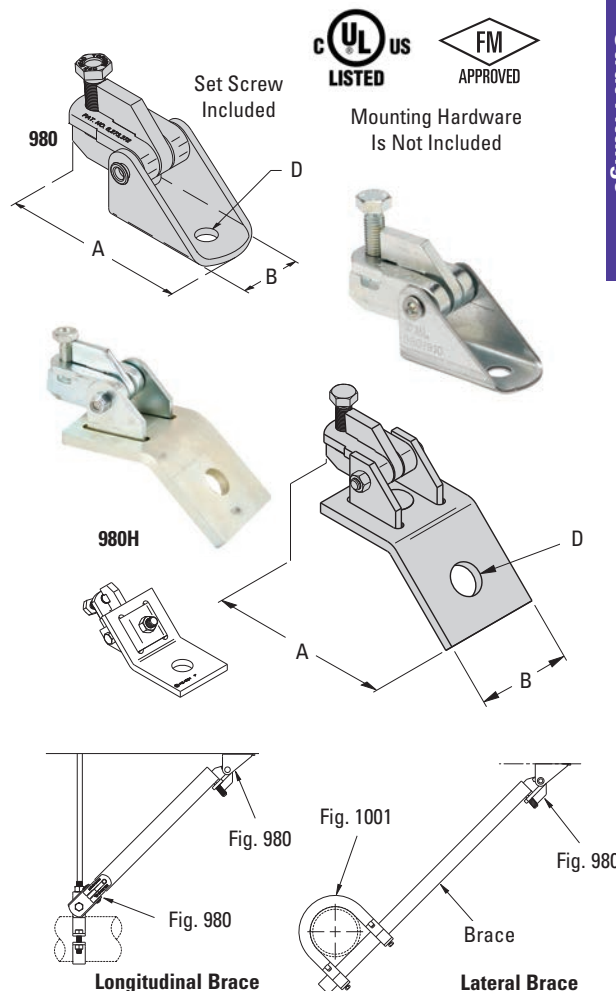

Part Number	Dimensions			Max. Horizontal Design Load (cULus) lbs./(kN)	Max. Horizontal Design Load** (FM)				Approx. Wt./100 lbs. (kg)
	A in. (mm)	B in. (mm)	D* in. (mm)		30°-44° lbs./(kN)	45°-59° lbs./(kN)	60°-74° lbs./(kN)	75°-90° lbs./(kN)	
980-3/8	5 1/4" (133.3)	1 7/8" (47.6)	1 3/32" (10.3)	2015 (8.96)	1320 (5.87)	1970 (8.76)	2310 (10.27)	2550 (11.34)	149 (67.6)
980-1/2	5 1/4" (133.3)	1 7/8" (47.6)	1 7/32" (13.5)						148 (67.1)
980-5/8	5 1/4" (133.3)	1 7/8" (47.6)	1 1/16" (17.5)						147 (66.7)
980-3/4	5 1/4" (133.3)	1 7/8" (47.6)	1 3/16" (20.5)						146 (66.2)
980H-7/8	6 3/4" (171.4)	3 1/2" (88.9)	1 5/16" (23.8)						402 (182.3)
980H-1	6 3/4" (171.4)	3 1/2" (88.9)	1 1/16" (27.0)						400 (181.4)
980H-1 1/8	6 3/4" (171.4)	3 1/2" (88.9)	1 3/16" (30.2)						397 (180.1)
980H-1 1/4	6 3/4" (171.4)	3 1/2" (88.9)	1 5/16" (33.3)						390 (176.9)

* Mounting attachment hole size.
** Installed with 1" or 1 1/4" Schedule 40 brace pipe.

Important! - For load information when using Fig. 980 with pre-installed or post-installed concrete anchors in compliance with NFPA 13 (2016) or ASCE 7-10, including prying factors, see load tables on pages AL1 thru AL21.

Eaton's B-Line series seismic bracing components are designed to be compatible only with other B-Line series bracing components, resulting in a listed seismic bracing assembly. Eaton B-Line Division warranty for seismic bracing components will be the warranty provided in Eaton B-Line Division standard terms and conditions of sale made available by Eaton, except that, in addition to the other exclusions from Eaton B-Line Division warranty, Eaton makes no warranty relating to B-Line series seismic bracing components that are combined with products not provided by Eaton.

Reference page 106 for general fitting and standard finish specifications.

Miscellaneous Seismic Fittings

TOLCO™ Fig. 981 - Fast Attach – Universal Swivel Sway Brace Attachment

Size Range: Fits bracing pipe 1" (25mm) thru 2" (50mm), 12 gauge (2.6mm) channel and all structural steel up to 1/4" (6.3mm) thick.

Fig. 981-S fits rod sizes 3/8" thru 5/8".

Fig. 981-L fits rod sizes 3/4" thru 7/8".

Material: Steel

Function: Multi-functional attachment to hanger rod, trapeze rod, structure or braced pipe fitting.

Features: Fits multiple sizes of bracing pipe, strut or structural steel. Swivel allows adjustment to various surface angles. Breakaway bolt heads assure verification of proper installation torque. Unique "fast attach" yoke design fits multiple rod sizes; 3/8" thru 5/8" and 3/4" thru 7/8". "Stackable" design allows installation of both lateral and longitudinal braces to be easily installed on a single hanger rod, with no disassembly.

Installation: Fig. 981 is the "braced pipe" attachment component of a lateral or longitudinal brace assembly. It is intended to be combined with the pipe hanger, all-thread rod, "bracing pipe" and TOLCO transitional and structural attachment component(s) to form a complete bracing assembly. NFPA 13 and or OSHPD guidelines should be followed.

To Install: Spin nut on top of hanger counterclockwise to loosen the nut and raise it above the top of the hanger. Attach Fig. 981 by slipping the open side of the 981 yoke onto the all thread rod above the top of the hanger. Tighten 3/8" cone point set screw on yoke until head breaks-off to ensure proper installation torque. Spin the hex nut clockwise and tighten securely. Insert brace pipe into the jaw of the 981 and tighten the cone point set screw until the head breaks off ensuring proper installation torque. Pivot brace pipe to proper angle and attach to structure using a TOLCO swivel structural attachment.

Finish: Electro-Galvanized

Order By: Figure number, rod size

US Patent Numbers

Pat. #6,273,372, Pat. #7,097,141, Pat. #7,654,043, Pat. #7,654,043 B2

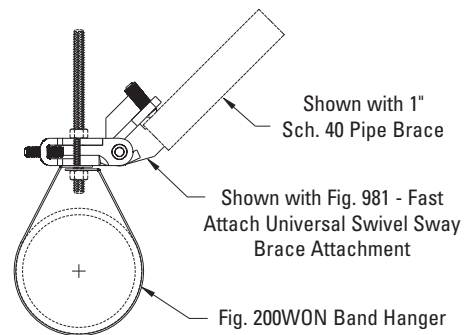
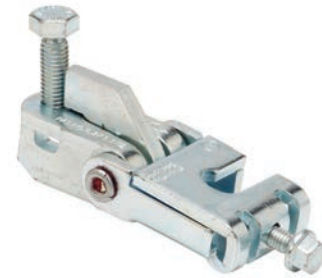
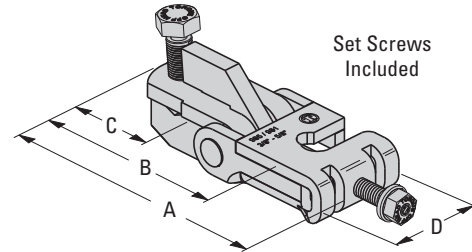

Part Number	Rod Size Range	A		B		C		D		Max. Horizontal Design Load lbs. (kN)	Approx. Wt./100 lbs. (kg)
		in.	(mm)	in.	(mm)	in.	(mm)	in.	(mm)		
981-S	3/8" thru 5/8"	5 1/8"	(130.2)	4 1/8"	(104.8)	1 1/4"	(31.7)	2 1/4"	(57.1)	2015 (8.96)	88 (39.9)
981-L	3/4" & 7/8"	5 1/8"	(130.2)	4 1/8"	(104.8)	1 1/4"	(31.7)	2 1/4"	(57.1)	2015 (8.96)	82 (37.2)

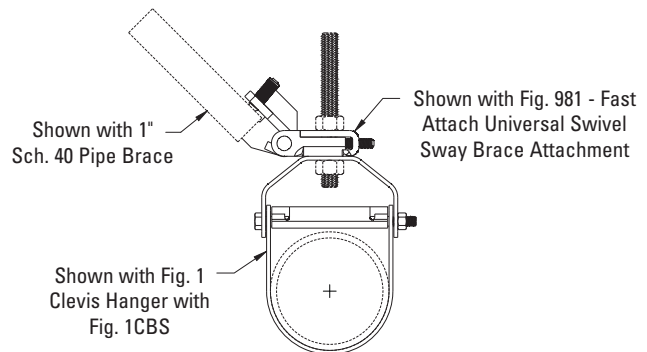
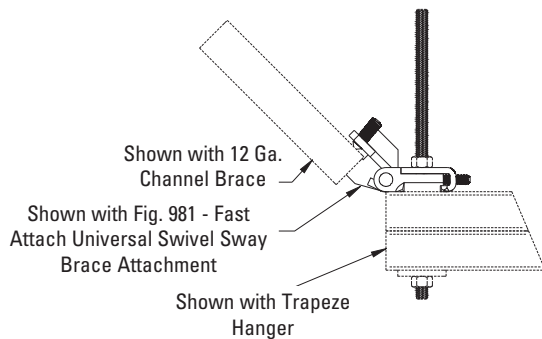

Reference page 106 for general fitting and standard finish specifications.

TOLCO™ Fig. 985 - Mechanical Fast Clamp

Size Range: Fig. 985-S fits rod sizes $\frac{3}{8}$ " thru $\frac{5}{8}$ "
 Fig. 985-L fits rod sizes $\frac{3}{4}$ " thru $\frac{7}{8}$ " rod sizes

Material: Steel

Function: Used for attachment of seismic bracing to pipe hanger or trapeze

Features: Allows up to 12" (304.8mm) of adjustability in brace length, when used with Fig. 986. Break-off set screw heads visually verify required installation torque. Unique "Fast Attach" yoke design allows Fig. 985 to be installed to hanger rods $\frac{3}{8}$ " thru $\frac{5}{8}$ " or $\frac{3}{4}$ " thru $\frac{7}{8}$ "

Finish: Electro-galvanized

Order By: Figure number, rod size & finish

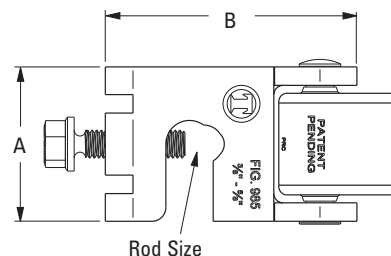
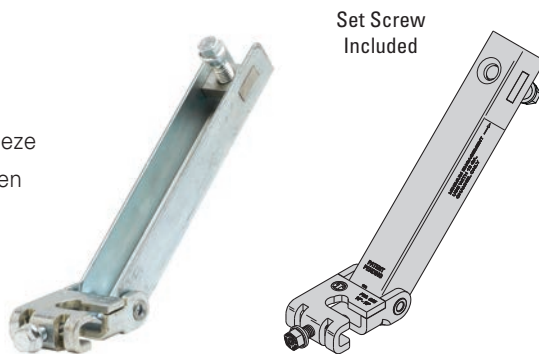

Part Number	Rod Size	A		B		Max. Horizontal Design Load lbs. (kN)	Approx. Wt./100 lbs. (kg)
		in.	(mm)	in.	(mm)		
985-S	$\frac{3}{8}$ " thru $\frac{5}{8}$ "	2"	(50.8)	1 1/2"	(38.1)	2015 (8.96)	204 (92.5)
985-L	$\frac{3}{4}$ " & $\frac{7}{8}$ "	2"	(50.8)	1 5/8"	(41.3)	2015 (8.96)	198 (89.8)

TOLCO™ Fig. 986 - Mechanical Fast Clamp

Size Range: Available with holes for $\frac{1}{2}$ "-13 thru $\frac{3}{4}$ "-10 fastener attachment.

Material: Steel

Function: Used for attachment of seismic bracing to structure or hanger.

Features: Allows up to 12" (304.8mm) of adjustability in brace length, when used with Fig. 985. Break-off set screw heads visually verify required installation torque. Swivel allows adjustment to various surface angles.

Finish: Electro-galvanized

Order By: Figure number, rod size & finish

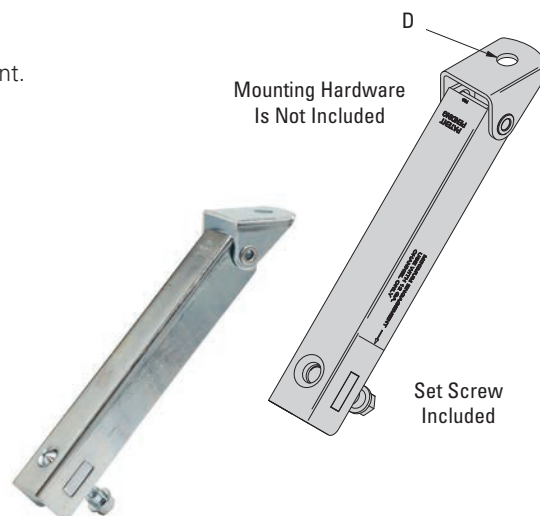

Part Number	Rod Size	Hole Dia. D		Max. Horizontal Design Load* lbs. (kN)	Approx. Wt./100 lbs. (kg)
		in.	(mm)		
986-1/2	$\frac{1}{2}$ "	9/16"	(14.3)	2015 (8.96)	204 (92.5)
986-5/8	$\frac{5}{8}$ "	11/16"	(17.5)	2015 (8.96)	203 (92.1)
986-3/4	$\frac{3}{4}$ "	13/16"	(20.6)	2015 (8.96)	202 (91.6)

* When used with $1\frac{5}{8}$ " (41.3mm) x $1\frac{5}{8}$ " (41.3mm) 12 Ga. (2.6mm) channel

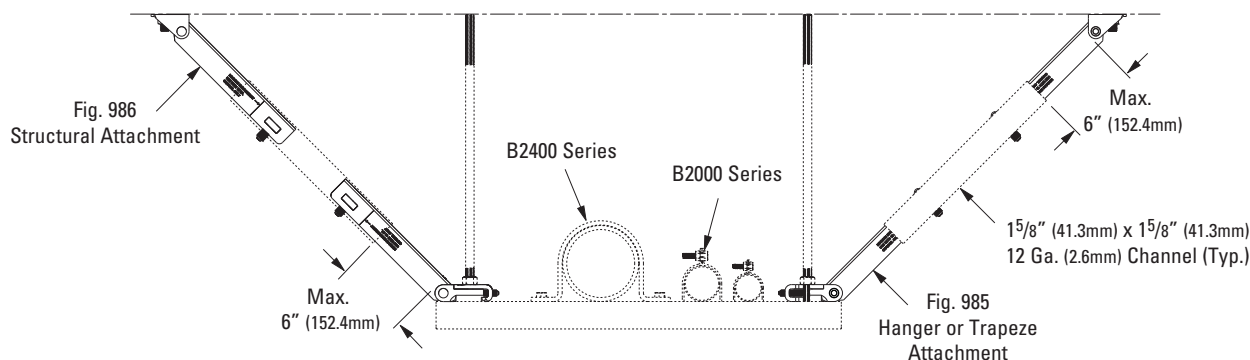

Reference page 106 for general fitting and standard finish specifications.

Braces

B261 - Two Hole 45° Knee Brace

- Standard finishes: ZN, GRN
- Design load determined by testing using a B335 hinged corner connection.
- Load ratings are for brace members only. Do not exceed allowable beam or column loads for strut channels.
- Safety Factor of 3



Part No.	A		B		Design Load		Wt./C	
	In.	mm	In.	mm	Lbs.	kN	Lbs.	kg
B261-8	8"	(203.2)	7 ³ / ₈ "	(187.3)	1500	(6.67)	119	(54.0)
B261-12	12"	(304.8)	10 ¹ / ₈ "	(257.2)	1020	(4.54)	165	(74.8)
B261-16	16 ⁵ / ₈ "	(422.3)	13 ³ / ₈ "	(339.7)	530	(2.36)	218	(98.9)
B261-18	18"	(457.2)	14 ⁷ / ₁₆ "	(366.7)	450	(2.00)	234	(106.1)
B261-24	24"	(609.6)	18 ¹¹ / ₁₆ "	(474.7)	250	(1.11)	303	(137.4)
B261-36	36"	(914.4)	27 ³ / ₁₆ "	(690.6)	110	(.49)	441	(200.0)

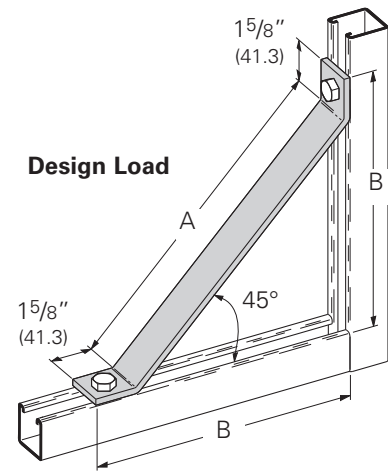

B631 - Two Hole 45° Tubing Knee Brace

- 1" (25.4) Square steel tubing
- Material: ASTM A513
- Standard finishes: ZN, GRN
- Design load determined by testing using a B335 hinged corner connection.
- Load ratings are for brace members only. Do not exceed allowable beam or column loads for strut channels.
- Safety Factor of 3



Part No.	A		Design Load		Wt./C	
	In.	mm	Lbs.	kN	Lbs.	kg
B631-18	18"	(457.2)	1500	(6.67)	145	(65.8)
B631-24	24"	(609.6)	1500	(6.67)	186	(84.4)
B631-30	30"	(762.0)	1500	(6.67)	225	(102.0)
B631-36	36"	(914.4)	1500	(6.67)	266	(120.6)
B631-42	42"	(1066.8)	1230	(5.47)	307	(139.2)
B631-48	48"	(1219.2)	940	(4.18)	348	(157.8)
B631-54	54"	(1371.6)	740	(3.29)	389	(176.4)
B631-60	60"	(1524.0)	600	(2.67)	430	(195.0)
B631-72	72"	(1828.8)	420	(1.87)	508	(230.4)
B631-84	84"	(2133.6)	310	(1.38)	589	(267.2)
B631-96	96"	(2438.4)	240	(1.07)	669	(303.5)

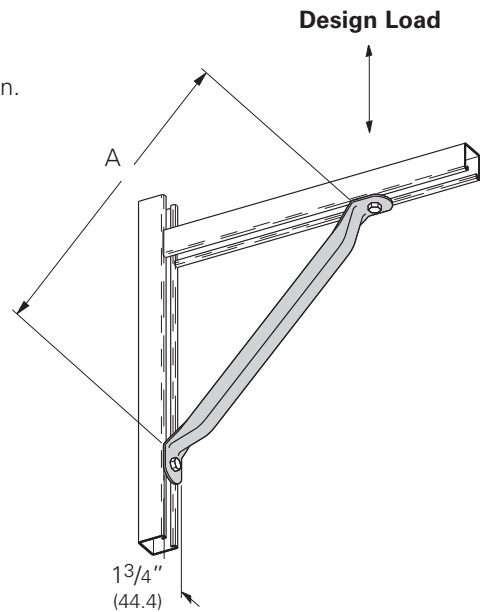

B632 - Two Hole Straight Tubing Brace

- 1" (25.4) Square steel tubing
- Material: ASTM A513
- Standard finishes: ZN, GRN



Part No.	A		Wt./C	
	In.	mm	Lbs.	kg
B632-18	18"	(457.2)	133	(60.3)
B632-24	24"	(609.6)	174	(78.9)
B632-30	30"	(762.0)	215	(97.5)
B632-36	36"	(914.4)	256	(116.1)
B632-42	42"	(1066.8)	295	(133.8)
B632-48	48"	(1219.2)	335	(151.9)
B632-54	54"	(1371.6)	380	(172.3)
B632-60	60"	(1524.0)	420	(190.5)
B632-72	72"	(1828.8)	500	(226.8)
B632-84	84"	(2133.6)	585	(265.3)
B632-96	96"	(2438.4)	670	(303.9)

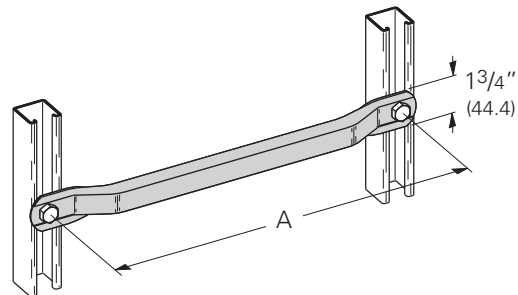

4Dimension compatible fitting

Reference page 106 for general fitting and standard finish specifications.

B169
Two Hole Splice
Clevis For B52

- Standard finishes: ZN, GRN
- Wt./C 84 Lbs. (38.1 kg)

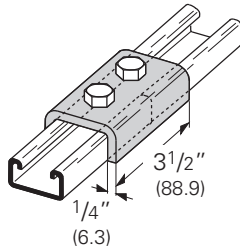

B168
Three Hole Splice
Clevis For B52

- Standard finishes: ZN, GRN
- Wt./C 126 Lbs. (57.1 kg)

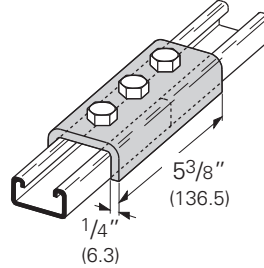

B167
Four Hole Splice
Clevis For B52

- Standard finishes: ZN, GRN
- Wt./C 178 Lbs. (80.7 kg)

PA GRN

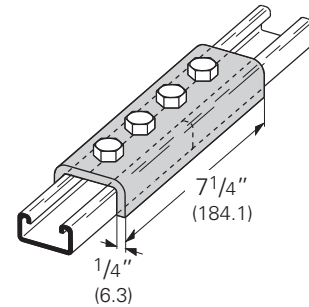

B170
Two Hole Splice
Clevis For B22 or B52A

- Standard finishes: ZN, GRN
- Wt./C 123 Lbs. (55.8 kg)

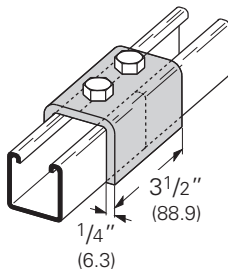

B171
Three Hole Splice
Clevis For B22 or B52A

- Standard finishes: ZN, GRN
- Wt./C 195 Lbs. (88.4 kg)

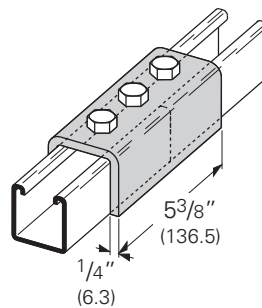

B172
Four Hole Splice
Clevis For B22 or B52A

- Standard finishes: ZN, GRN
- Wt./C 266 Lbs. (120.6 kg)

PA ZN
GRN

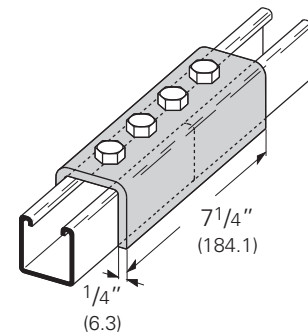

B172-12
Four Hole Splice Clevis For B12

- Standard finishes: ZN, GRN
- Wt./C 326 Lbs. (147.8 kg)

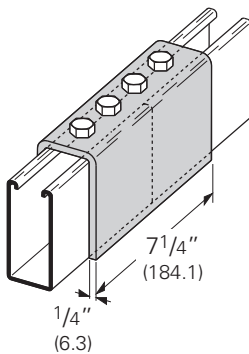

B172-22A
Four Hole Splice
Clevis For B11 or B22A

- Standard finishes: ZN, GRN
- Wt./C 406 Lbs. (184.1 kg)

PA GRN

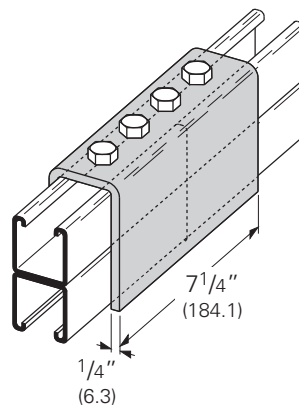

B450
U-Washer

- Material: ASTM A1011 HSLAS Gr. 50
- Standard finishes: ZN, GRN

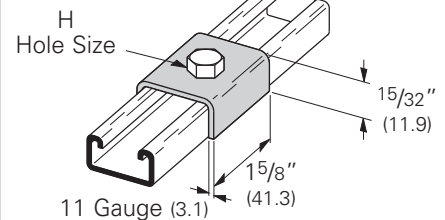

Part No. & Size	Hole Size H	Wt./C
	Lbs. kg	Lbs. kg
B450-1/4	5/16" (7.9)	14 (6.3)
B450-3/8	7/16" (11.1)	14 (6.3)
B450-1/2	9/16" (14.3)	13 (5.8)
B450-5/8	11/16" (17.4)	13 (5.8)
B450-3/4	13/16" (20.6)	13 (5.8)

PA Pre-assembled fitting.

Reference page 106 for general fitting and standard finish specifications.

'U' Fittings

B527 Three Hole Offset Plate Connection

- Standard finishes: ZN, GRN
- Wt./C 54 Lbs. (24.5 kg)

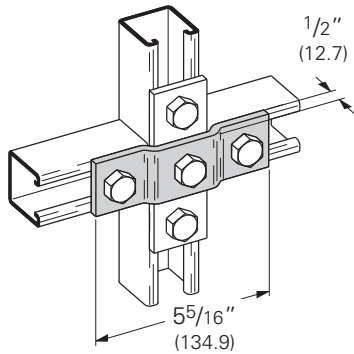

B116-52 Three Hole U-Support

- Standard finishes: ZN, GRN
- Wt./C 70 Lbs. (31.7 kg)

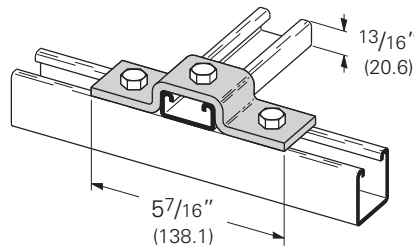

B116-42 Three Hole U-Support

- Standard finishes: ZN, GRN
- Wt./C 75 Lbs. (34.0 kg)

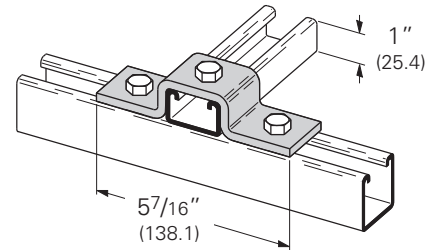

B116-32 Three Hole U-Support

- Standard finishes: ZN, GRN
- Wt./C 84 Lbs. (38.1 kg)

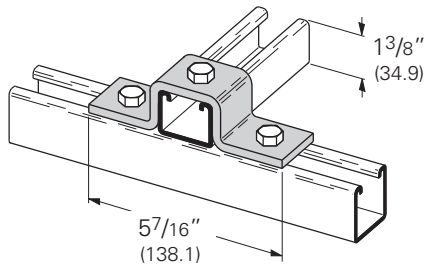

B116-32A Three Hole U-Support

- Standard finishes: ZN, GRN
- Wt./C 116 Lbs. (52.6 kg)

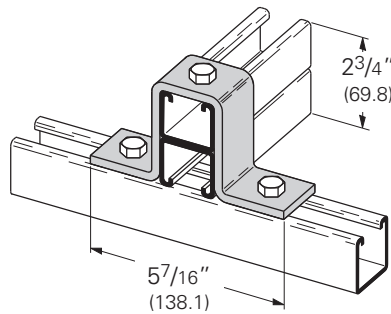

B116-12 Three Hole U-Support

- Standard finishes: ZN, GRN
- Wt./C 108 Lbs. (49.0 kg)

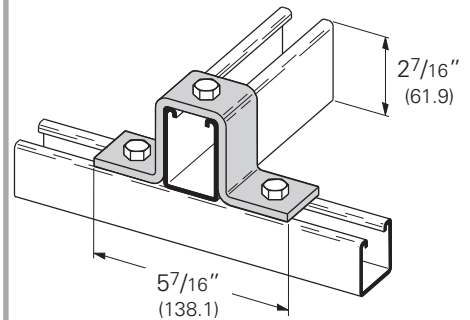

B107 Five Hole U-Support

- Standard finishes: ZN, GRN, HDG
- Wt./C 85 Lbs. (38.5 kg)

PA ^{ZN}
GRN

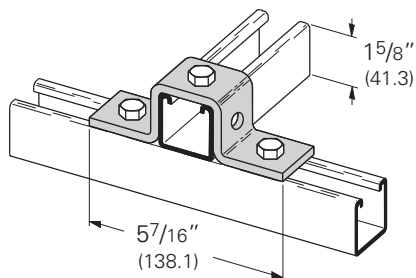

B107-22A Three Hole U-Support

- Standard finishes: ZN, GRN
- Wt./C 126 Lbs. (57.1 kg)

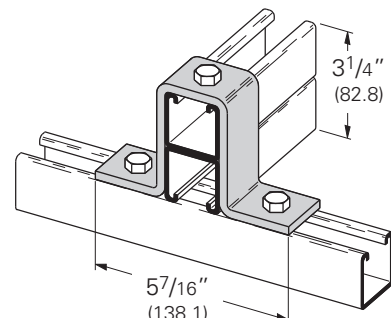

B588 Three Hole U-Support

- Standard finishes: ZN, GRN
- Wt./C 157 Lbs. (71.2 kg)

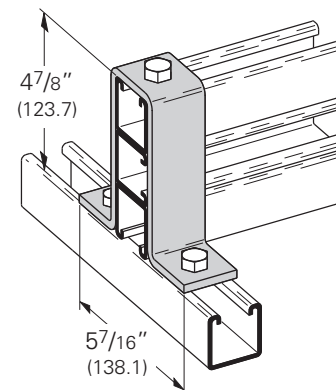

PA Pre-assembled fitting.

Reference page 106 for general fitting and standard finish specifications.

B412
Three Hole
Offset U-Support

- Standard finishes: ZN, GRN
- Wt./C 89 Lbs. (40.3 kg)

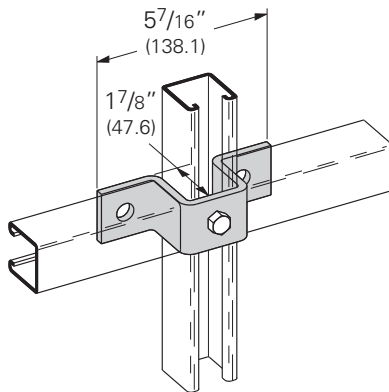

B107S
Five Hole U-Support

- Material: 7 Gauge (4.5)
ASTM A1011 33,000 PSI min. yield
- Standard finishes: ZN, GRN
- Wt./C 51 Lbs. (23.1 kg)

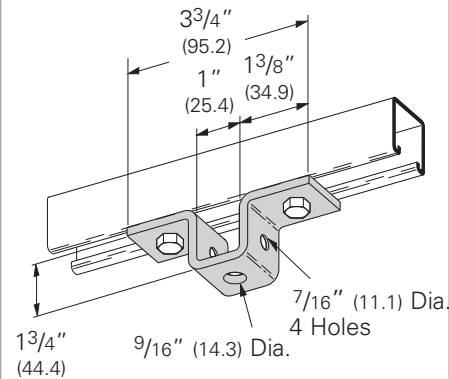

B596
Three Hole Swivel Clevis

- Material: 7 Gauge (4.5)
- Standard finishes: ZN, GRN
- Wt./C 53 Lbs. (24.0 kg)

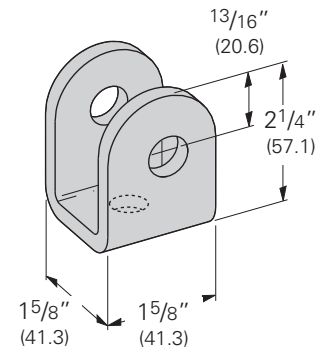

B578
Three Hole Light-Weight
U-Support

- Material: 10 Gauge (3.4)
ASTM A1011 HSLAS Gr. 50
- Standard finishes: ZN, GRN
- Wt./C 18 Lbs. (8.1 kg)

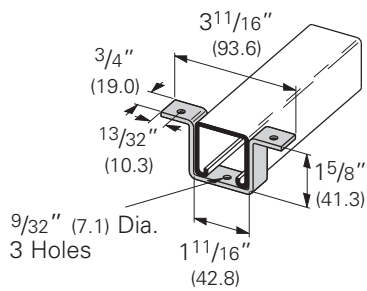

B594
Five Hole U-Support

- Standard finishes: ZN, GRN
- Wt./C 106 Lbs. (48.1 kg)

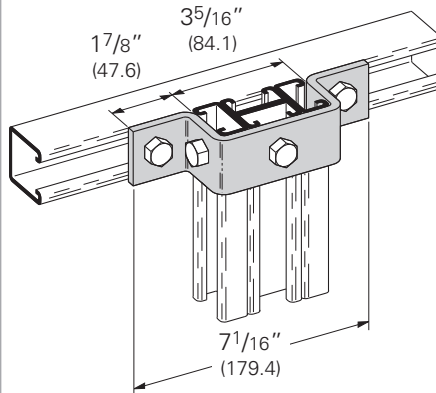

B266
Six Hole U-Support

- Standard finishes: ZN, GRN
- Wt./C 105 Lbs. (47.6 kg)

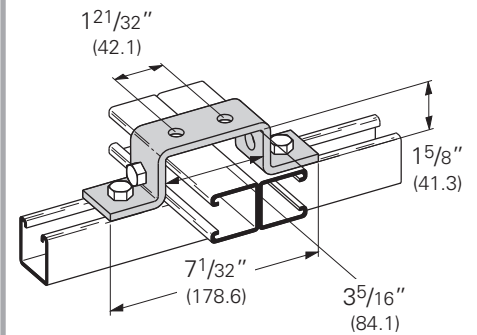

B425
Six Hole U-Support

- Standard finishes: ZN, GRN
- Wt./C 167 Lbs. (75.7 kg)

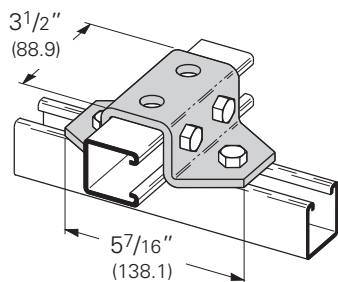

B581
Eight Hole U-Support

- Standard finishes: ZN, GRN
- Wt./C 201 Lbs. (91.2 kg)

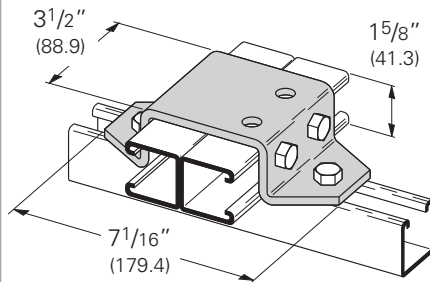

B519
Eight Hole U-Support

- Standard finishes: ZN, GRN
- Wt./C 266 Lbs. (102.5 kg)

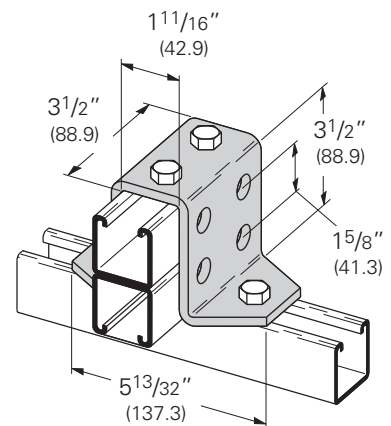

Reference page 106 for general fitting and standard finish specifications.

'U' Fittings

B333 Slotted Three Hole U-Support For B22

- Standard finishes: ZN, GRN

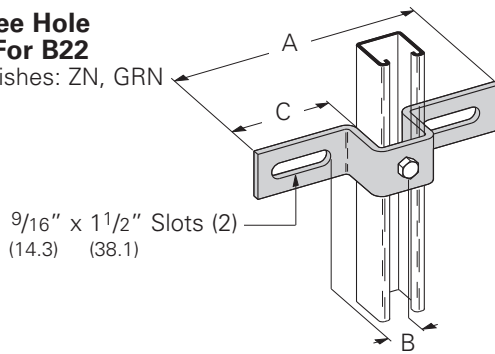

Part No.	A		B		C		Wt./C	
	In.	mm	In.	mm	In.	mm	Lbs.	kg
B333-1	7 1/2"	(190.5)	1 5/16"	(33.3)	2 7/8"	(73.0)	103	(46.7)
B333-2	8 1/2"	(215.9)	1 15/16"	(49.2)	3 3/8"	(85.7)	115	(52.1)
B333-3	10 3/8"	(263.5)	2 7/8"	(73.0)	4 5/16"	(109.5)	135	(61.2)

B451 Slotted Three Hole U-Support With Gusset For B22

- Consists of B333-1, 2, or 3 with gusset plate welded on back.
- Material: ASTM A1011 HSLAS Gr. 50
- Standard finishes: ZN, GRN

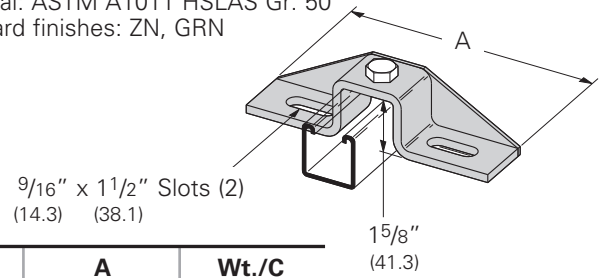

Part No.	A		Wt./C	
	In.	mm	Lbs.	kg
B451-1	7 1/2"	(190.5)	137	(62.1)
B451-2	8 1/2"	(215.9)	156	(70.7)
B451-3	10 3/8"	(263.5)	172	(78.0)

B408 Two Hole Bus Duct Clevis

- Standard finishes: ZN, GRN

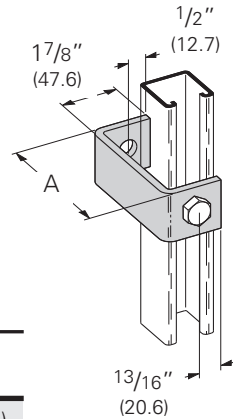

Part No.	A		Wt./C	
	In.	mm	Lbs.	kg
B408-1	2 13/32"	(61.1)	58	(26.3)
B408-2	3 25/32"	(96.0)	76	(34.5)
B408-3	4 3/4"	(762.0)	88	(39.9)

B358 Two Hole Clevis

- Standard finishes: ZN, GRN

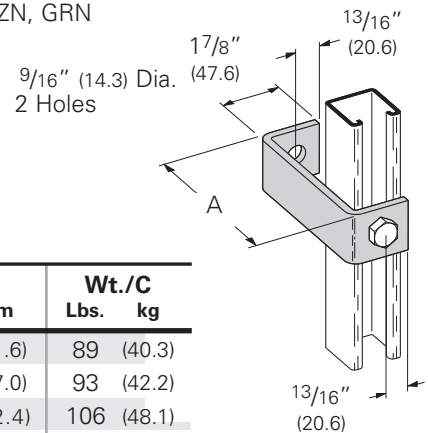

Part No.	A		Wt./C	
	In.	mm	Lbs.	kg
B358-4	4"	(101.6)	89	(40.3)
B358-5	5"	(127.0)	93	(42.2)
B358-6	6"	(152.4)	106	(48.1)
B358-7	7"	(177.8)	118	(53.5)
B358-8	8"	(203.2)	132	(59.9)

B173 Four Hole Clevis

- Standard finishes: ZN, GRN
- Wt./C 71 Lbs. (32.2 kg)

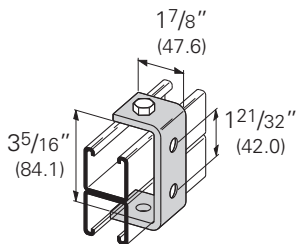

B595 Three Hole Clevis

- Standard finishes: ZN, GRN
- Wt./C 75 Lbs. (34.0 kg)

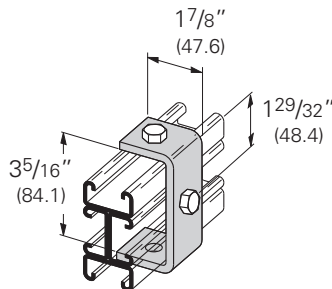

B405 Three Hole Suspension Clevis

- Standard finishes: ZN, GRN
- Wt./C 75 Lbs. (34.0 kg)

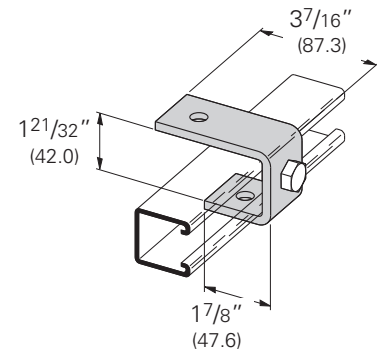

Reference page 106 for general fitting and standard finish specifications.

B398-1
Three Hole Cup Support

- Standard finishes: ZN, GRN
- Wt./C 73 Lbs. (33.1 kg)

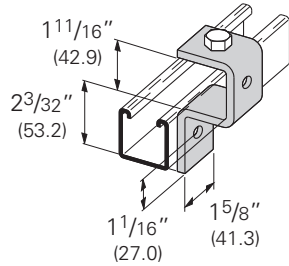

B400
Three Stud Ring Connection

- 1/2"-13 stud protrudes 1" (25.4mm)
- Standard finishes: ZN
- Wt./C 85 Lbs. (38.5 kg)

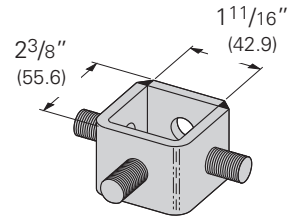

B400-1
One Stud Ring Connection

- 1/2"-13 stud protrudes 1" (25.4mm)
- Standard finishes: ZN
- Wt./C 53 Lbs. (24.0 kg)

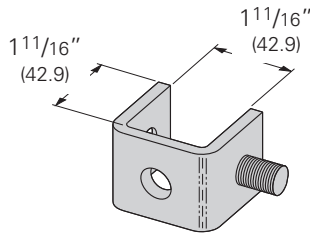

B400-2
One Stud Ring Connection

- 1/2"-13 stud protrudes 1" (25.4mm)
- Standard finishes: ZN
- Wt./C 40 Lbs. (18.1 kg)

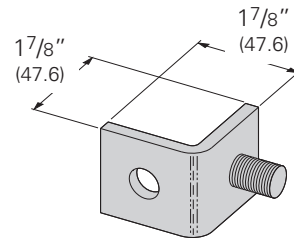

B400-3
Two Stud Ring Connection

- 1/2"-13 stud protrudes 1" (25.4mm)
- Standard finishes: ZN
- Wt./C 59 Lbs. (26.7 kg)

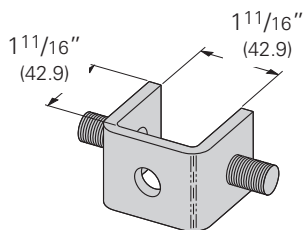

B400-4
Two Stud Ring Connection

- 1/2"-13 stud protrudes 1" (25.4mm)
- Standard finishes: ZN
- Wt./C 59 Lbs. (26.7 kg)

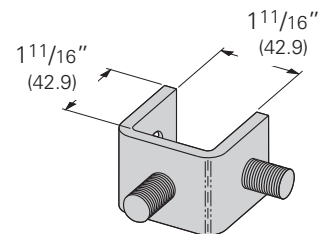

Reference page 106 for general fitting and standard finish specifications.

'Z' Fittings

B526 Two Hole Offset Z-Support

- Standard finishes: ZN, GRN
- Wt./C 38 Lbs. (17.2 kg)

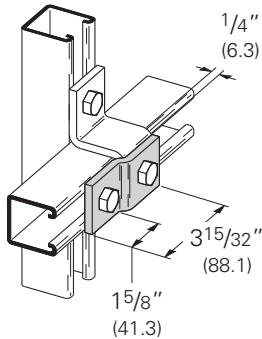

B106-52 Two Hole Offset Z-Support for B52

- Standard finishes: ZN, GRN
- Wt./C 40 Lbs. (18.1 kg)

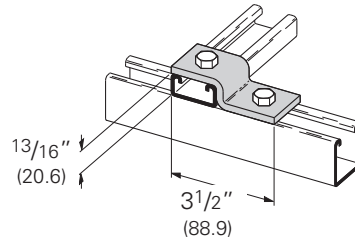

B106-42 Two Hole Offset Z-Support for B42

- Standard finishes: ZN, GRN
- Wt./C 44 Lbs. (20.0 kg)

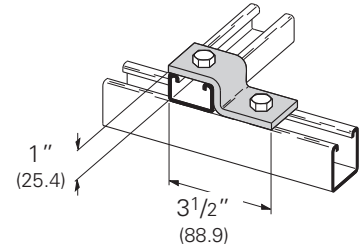

B106-32 Two Hole Offset Z-Support for B32

- Standard finishes: ZN, GRN
- Wt./C 51 Lbs. (23.1 kg)

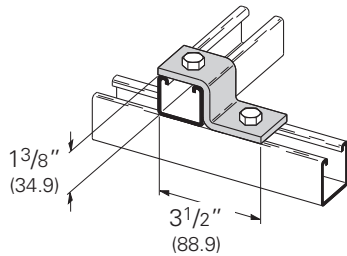

B106-12 Two Hole Offset Z-Support for B12

- Standard finishes: ZN, GRN
- Wt./C 63 Lbs. (28.6 kg)

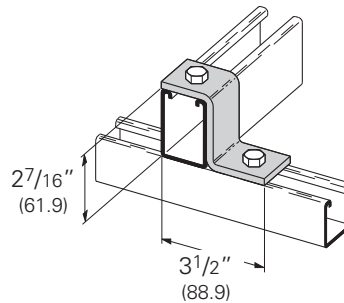

B105 Three Hole Offset Z-Support for B22

- Standard finishes: ZN, GRN, HDG
- Wt./C 51 Lbs. (23.1 kg)

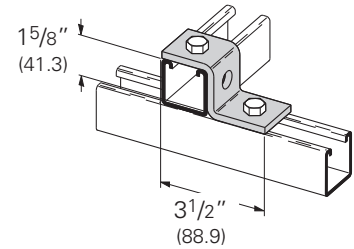

B110 Three Hole Offset Z-Support for B11

- Standard finishes: ZN, GRN
- Wt./C 70 Lbs. (31.7 kg)

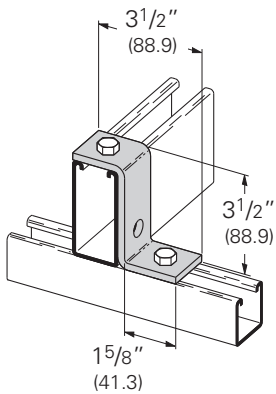

B586 Two Hole Z-Support

- Standard finishes: ZN, GRN
- Wt./C 90 Lbs. (40.8 kg)

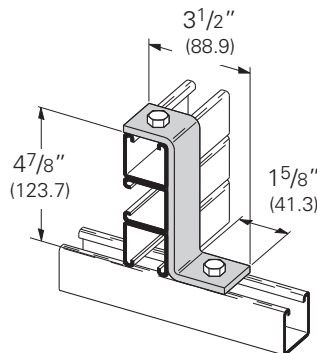

B108 Two Hole Offset Z-Support

- Standard finishes: ZN, GRN
- Wt./C 55 Lbs. (24.9 kg)

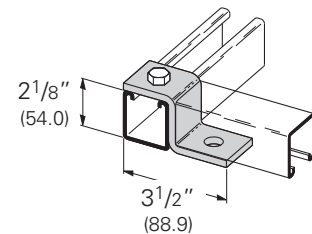

Reference page 106 for general fitting and standard finish specifications.

B387 Two Hole Z-Bus Duct Connection

- Standard finishes: ZN, GRN

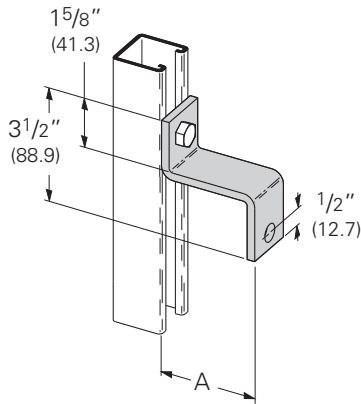

Part No.	A		Wt./C	
	In.	mm	Lbs.	kg
B387	4 ³ / ₄ "	(120.6)	89	(40.3)
B387-1	3 ²⁵ / ₃₂ "	(96.0)	78	(35.4)
B387-2	2 ¹³ / ₃₂ "	(61.1)	62	(28.1)

B407 Two Hole Z-Support

- Standard finishes: ZN, GRN

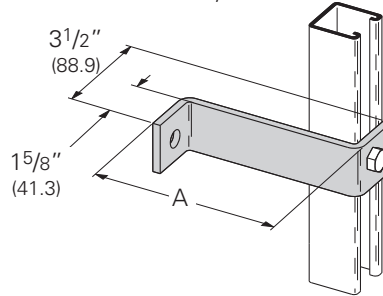

Part No.	A		Wt./C	
	In.	mm	Lbs.	kg
B407-4	4"	(101.6)	77	(34.9)
B407-5	5"	(127.0)	95	(43.1)
B407-6	6"	(152.4)	98	(44.4)
B407-7	7"	(177.8)	105	(47.6)
B407-8	8"	(203.2)	120	(54.4)
B407-9⁵/₈	9 ⁵ / ₈ "	(244.5)	138	(62.6)

B111 Three Hole Sheath Corner Connection

- Standard finishes: ZN, GRN
- Wt./C 68 Lbs. (30.8 kg)

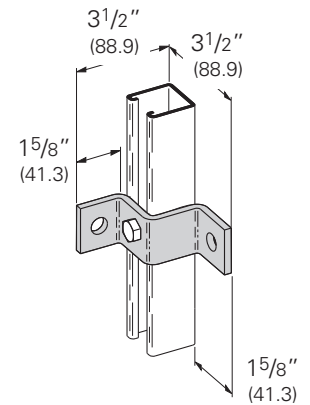

B410-52 Channel Hanger Bracket for B52

- Material: 11 Gauge (3.0)
ASTM A1011 HSLAS Gr. 50
- Standard finishes: ZN, GRN
- Wt./C 6.7 Lbs. (3.0 kg)

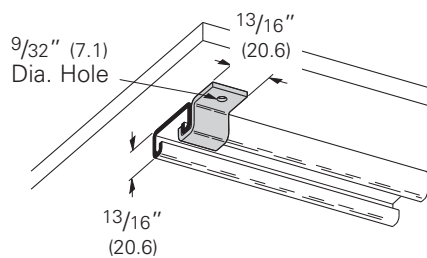

B410-32 Channel Hanger Bracket for B32

- Material: 11 Gauge (3.0)
ASTM A1011 HSLAS Gr. 50
- Standard finishes: ZN, GRN
- Wt./C 8.3 Lbs. (3.7 kg)

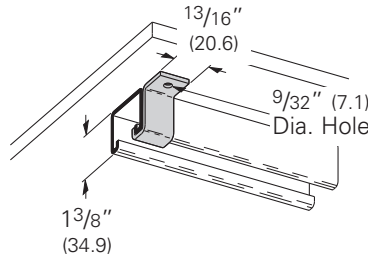

B410-22 Channel Hanger Bracket for B22

- Material: 11 Gauge (3.0)
ASTM A1011 HSLAS Gr. 50
- Standard finishes: ZN, GRN
- Wt./C 9 Lbs. (4.1 kg)

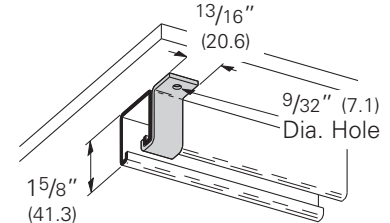

B410-12 Channel Hanger Bracket for B12

- Material: 11 Gauge (3.0)
ASTM A1011 HSLAS Gr. 50
- Standard finishes: ZN, GRN
- Wt./C 11.2 Lbs. (5.1 kg)

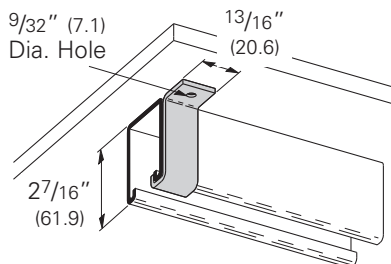

B410-11 Channel Hanger Bracket for B11

- Material: 11 Gauge (3.0)
ASTM A1011 HSLAS Gr. 50
- Standard finishes: ZN, GRN
- Wt./C 13.4 Lbs. (6.1 kg)

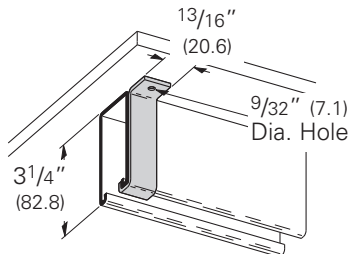

B580 Five Hole Gussetted Z-Support

- Standard finishes: ZN, GRN
- Wt./C 100 Lbs. (45.3 kg)

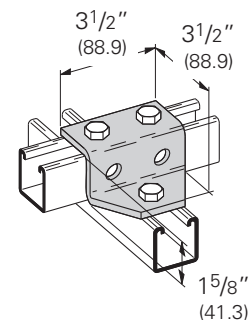

Reference page 106 for general fitting and standard finish specifications.

'Z' & Wing Fittings

B515 Adjustable Offset Gusseted Z-Support

- Standard finishes: ZN, GRN
- Wt./C 93 Lbs. (42.2 kg)

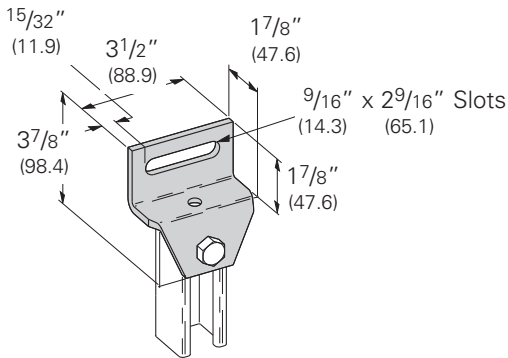

B428 Eight Hole Gusseted Corner Connection

- Standard finishes: ZN, GRN
- Wt./C 203 Lbs. (92.1 kg)

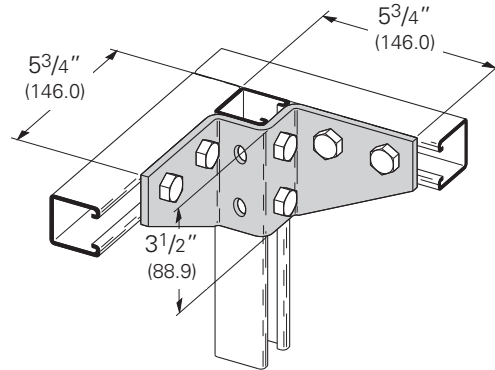

B267R Three Hole Single Corner Connection (Right Hand)

- Standard finishes: ZN, GRN
- Wt./C 54 Lbs. (24.5 kg)

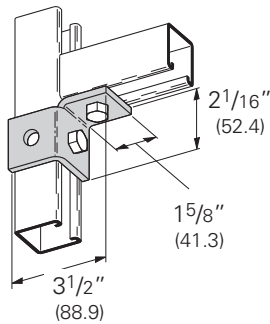

B267L Three Hole Single Corner Connection (Left Hand)

- Standard finishes: ZN, GRN
- Wt./C 54 Lbs. (24.5 kg)

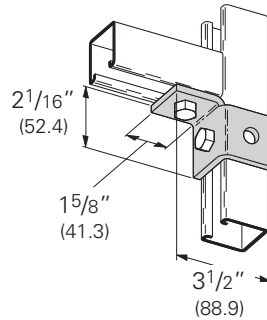

B270R Four Hole Single Corner Connection (Right Hand)

- Standard finishes: ZN, GRN
- Wt./C 77 Lbs. (34.9 kg)

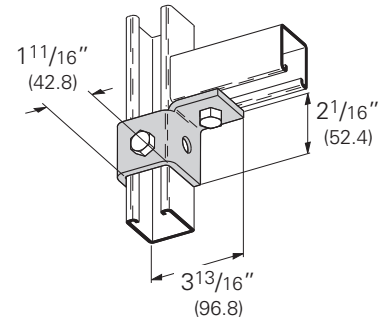

B270L Four Hole Single Corner Connection (Left Hand)

- Standard finishes: ZN, GRN
- Wt./C 77 Lbs. (34.9 kg)

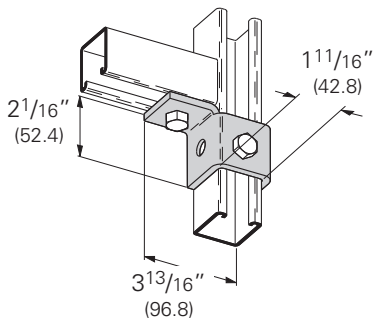

B268R Five Hole Single Corner Connection (Right Hand)

- Standard finishes: ZN, GRN
- Wt./C 100 Lbs. (45.3 kg)

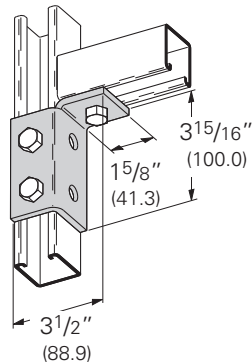

B268L Five Hole Single Corner Connection (Left Hand)

- Standard finishes: ZN, GRN
- Wt./C 100 Lbs. (45.3 kg)

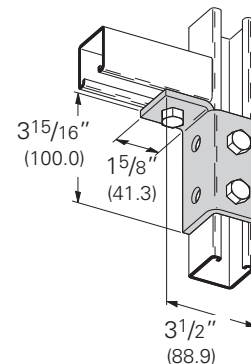

Reference page 106 for general fitting and standard finish specifications.

B269R
Six Hole Single Corner Connection (Right Hand)

- Standard finishes: ZN, GRN
- Wt./C 120 Lbs. (54.4 kg)

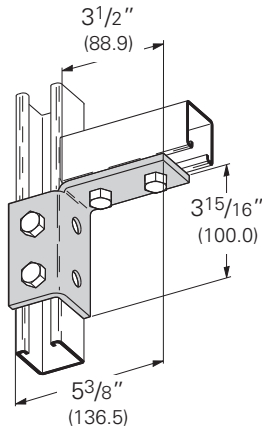

B269L
Six Hole Single Corner Connection (Left Hand)

- Standard finishes: ZN, GRN
- Wt./C 120 Lbs. (54.4 kg)

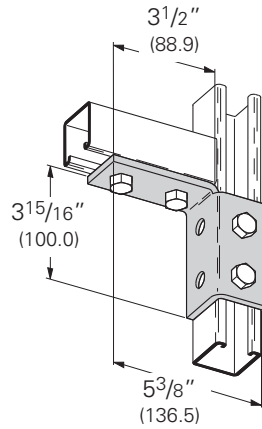

B119
Six Hole Double Corner Connection

- Standard finishes: ZN, GRN
- Wt./C 71 Lbs. (32.2 kg)

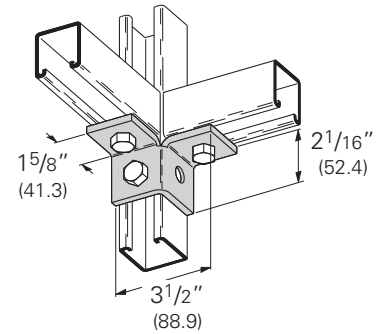

B120
Six Hole Double Corner Connection

- Standard finishes: ZN, GRN
- Wt./C 110 Lbs. (49.9 kg)

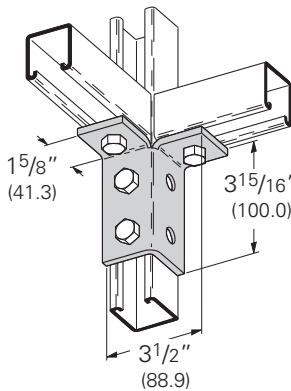

B121
Eight Hole Double Corner Connection

- Standard finishes: ZN, GRN
- Wt./C 152 Lbs. (68.9 kg)

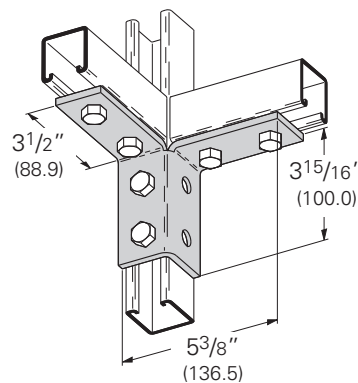

B271
Five Hole Double Wing Connection

- Standard finishes: ZN, GRN
- Wt./C 95 Lbs. (43.1 kg)

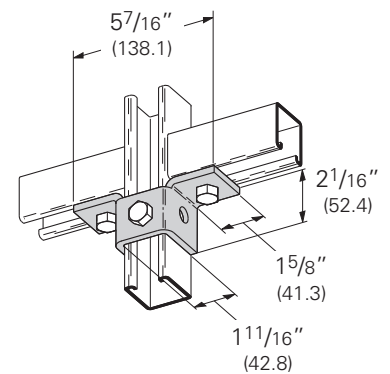

B272
Eight Hole Double Wing Connection

- Standard finishes: ZN, GRN
- Wt./C 156 Lbs. (70.7 kg)

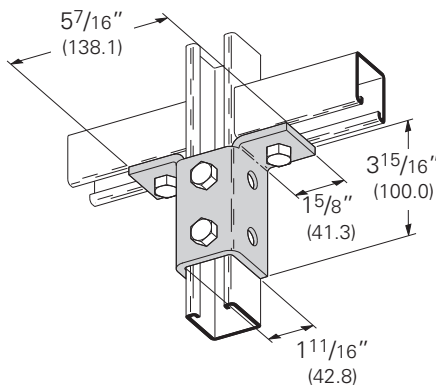

B273
Ten Hole Double Wing Connection

- Standard finishes: ZN, GRN
- Wt./C 185 Lbs. (83.9 kg)

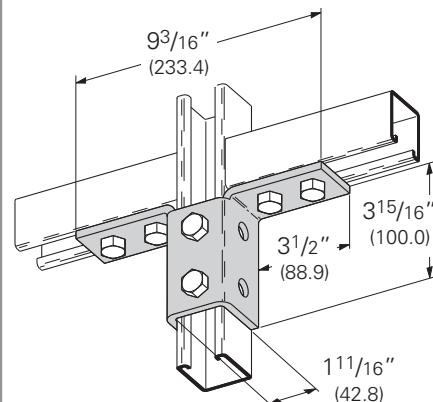

B122
Six Hole Triple Wing Connection

- Standard finishes: ZN, GRN
- Wt./C 110 Lbs. (49.9 kg)

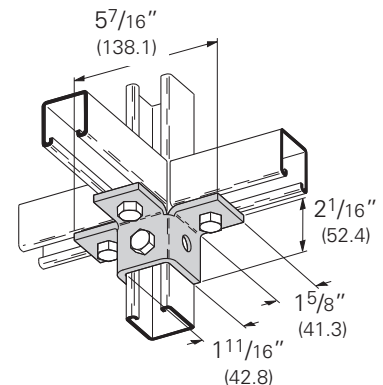

Reference page 106 for general fitting and standard finish specifications.

Wing Fittings

B123 Twelve Hole Triple Wing Connection

- Standard finishes: ZN, GRN
- Wt./C 234 Lbs. (106.1 kg)

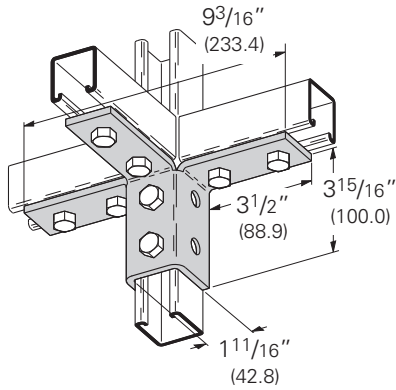

B124 Nine Hole Triple Wing Connection

- Standard finishes: ZN, GRN
- Wt./C 177 Lbs. (80.3 kg)

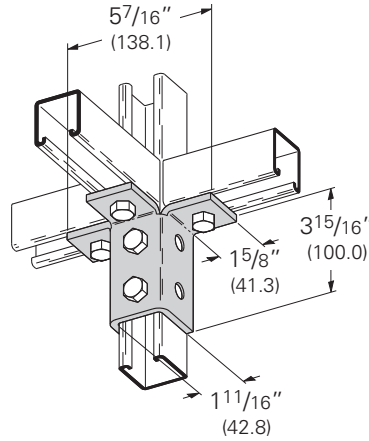

B276 Fourteen Hole Double Corner Gusseted Connection

- Standard finishes: ZN, GRN
- Wt./C 196 Lbs. (88.9 kg)

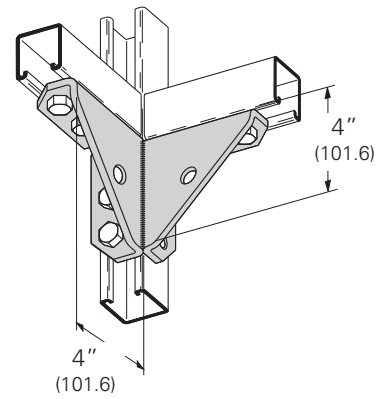

B274R Eight Hole Single Corner Gusseted Connection (Right Hand)

- Standard finishes: ZN, GRN
- Wt./C 176 Lbs. (79.8 kg)

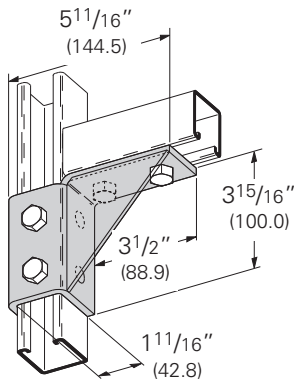

B274L Eight Hole Single Corner Gusseted Connection (Left Hand)

- Standard finishes: ZN, GRN
- Wt./C 176 Lbs. (79.8 kg)

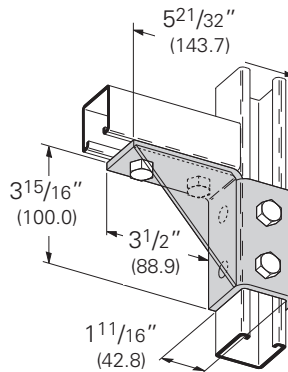

B495 Ten Hole Double Wing Gusseted Connection

- Standard finishes: ZN, GRN
- Wt./C 240 Lbs. (108.8 kg)

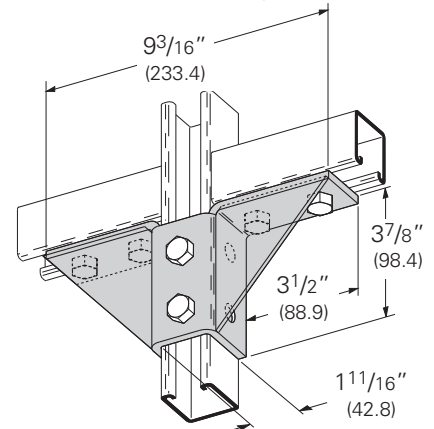

B277 Twelve Hole Triple Wing Gusseted Connection

- Standard finishes: ZN, GRN
- Wt./C 285 Lbs. (129.3 kg)

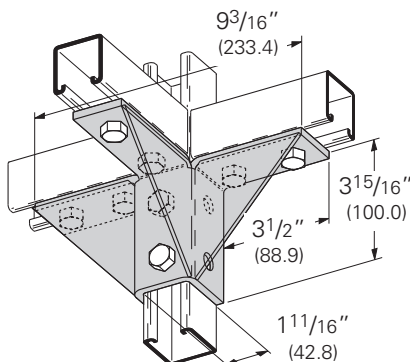

B362 Eight Hole Double Corner Gusseted Connection

- Standard finishes: ZN, GRN
- Wt./C 226 Lbs. (102.5 kg)

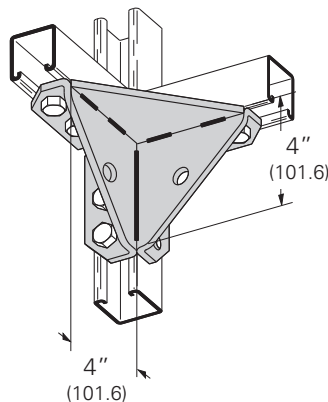

B571 Eight Hole Wing Connection

- Standard finishes: ZN, GRN
- Wt./C 201 Lbs. (91.2 kg)

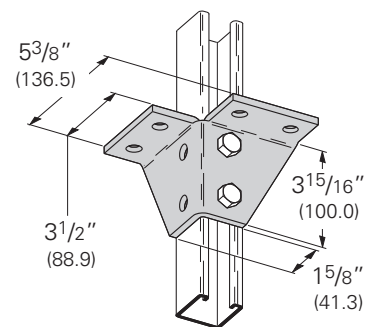

Reference page 106 for general fitting and standard finish specifications.

B346L
Eight Hole Double Corner Gussetted Connection
(Left Hand)

- Standard finishes: ZN, GRN
- Wt./C 242 Lbs. (109.8 kg)

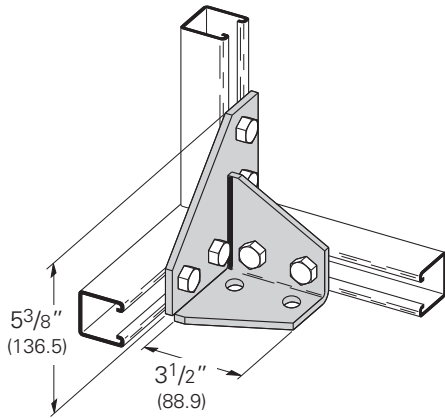

B346R
Eight Hole Double Corner Gussetted Connection
(Right Hand)

- Standard finishes: ZN, GRN
- Wt./C 242 Lbs. (109.8 kg)

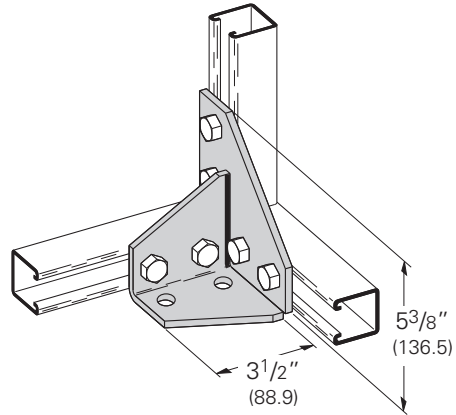

B279
Post Base for B22

- Standard finishes: ZN, GRN
- Wt./C 314 Lbs. (142.4 kg)

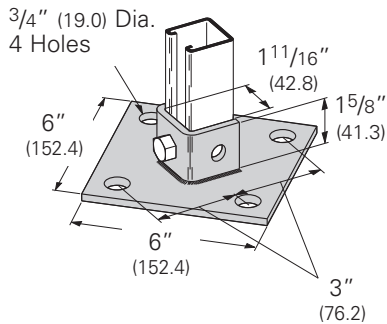

B279SQ
Post Base for B22

- Standard finishes: ZN, GRN
- Wt./C 314 Lbs. (142.4 kg)

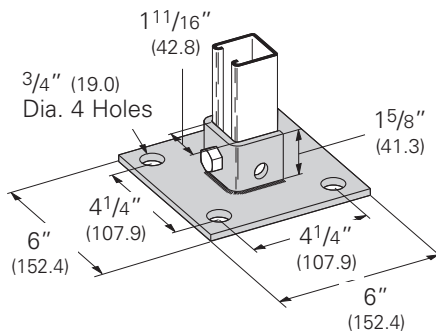

B279FL
Post Base for B22

- Standard finishes: ZN, GRN
- Wt./C 230 Lbs. (104.3 kg)

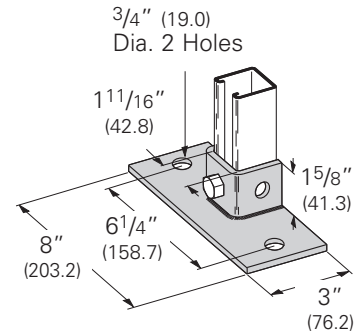

B280
Post Base for B22

- Standard finishes: ZN, GRN, HDG, SS4, AL
- Wt./C 392 Lbs. (177.8 kg)

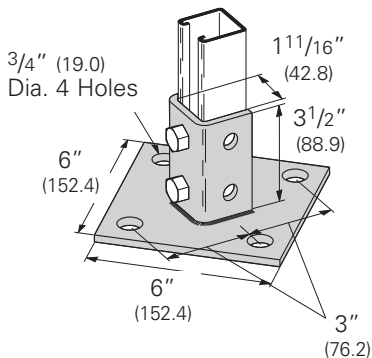

B280SQ
Post Base for B22

- Standard finishes: ZN, GRN, HDG, SS4, AL
- Wt./C 392 Lbs. (177.8 kg)

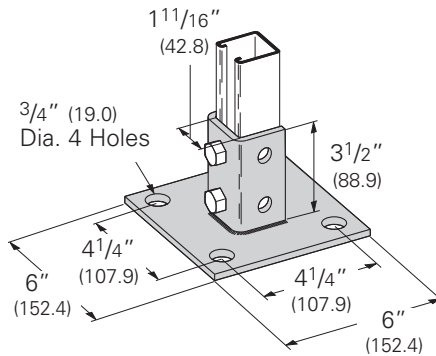

B280FL
Post Base for B22

- Standard finishes: ZN, GRN, HDG, SS4
- Wt./C 312 Lbs. (141.5 kg)

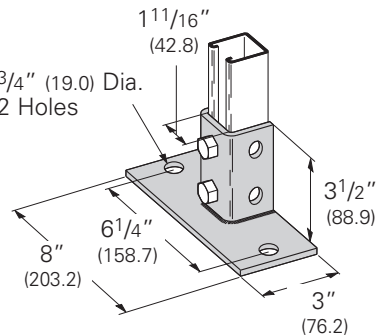

Reference page 106 for general fitting and standard finish specifications.

Post Bases

B281A
Post Base for B22A, B, C, ETC.

- Standard finishes: ZN, GRN
- Wt./C 330 Lbs. (149.7 kg)

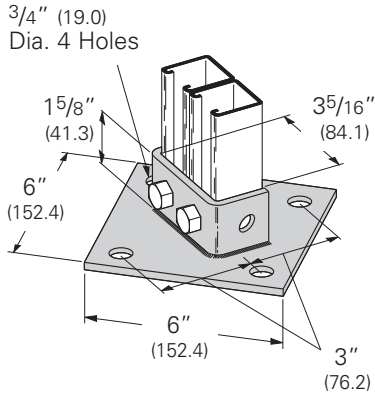

B281ASQ
Post Base for B22A, B, C, Etc.

- Standard finishes: ZN, GRN
- Wt./C 330 Lbs. (149.7 kg)

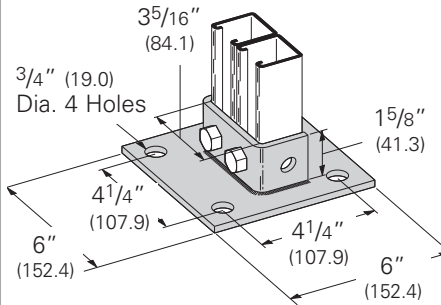

B281AFL
Post Base for B22A, B, C, Etc.

- Standard finishes: ZN, GRN
- Wt./C 250 Lbs. (113.4 kg)

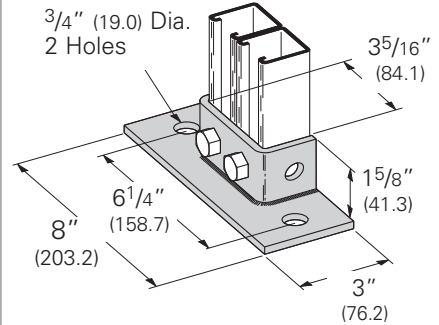

B281
Post Base for B22A, B, C, Etc.

- Standard finishes: ZN, GRN, HDG
- Wt./C 400 Lbs. (181.4 kg)

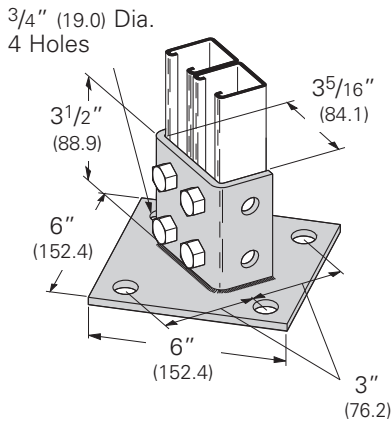

B281SQ
Post Base for B22A, B, C, Etc.

- Standard finishes: ZN, GRN, HDG, SS4
- Wt./C 400 Lbs. (181.4 kg)

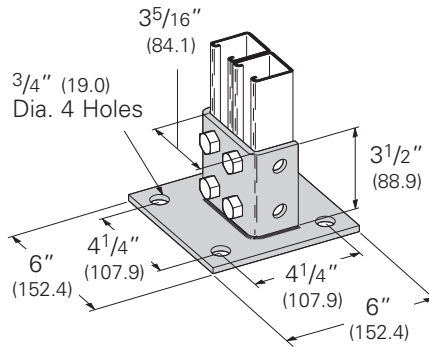

B281FL
Post Base for B22A, B, C, Etc.

- Standard finishes: ZN, GRN
- Wt./C 320 Lbs. (145.1 kg)

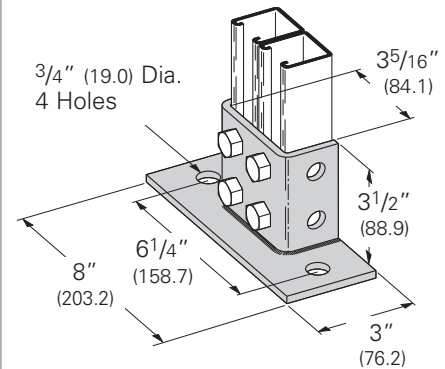

B281M
Post Base for B22-2PL

- Standard finishes: ZN, GRN
- Wt./C 470 Lbs. (213.2 kg)

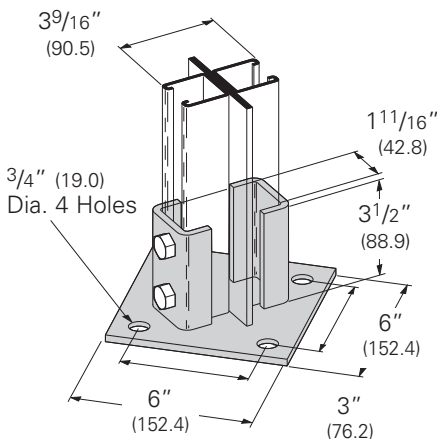

B281MSQ
Post Base for B22-2PL

- Standard finishes: ZN, GRN
- Wt./C 470 Lbs. (213.2 kg)

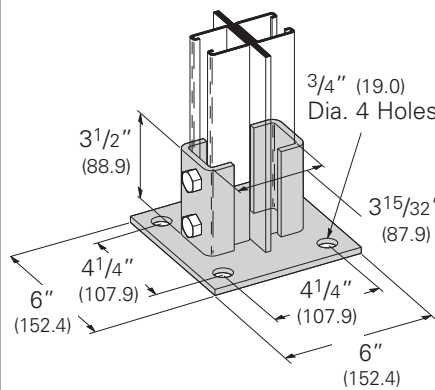

B570
Post Base for Four Channel Combinations

- Standard finishes: ZN, GRN
- Wt./C 397 Lbs. (180.1 kg)

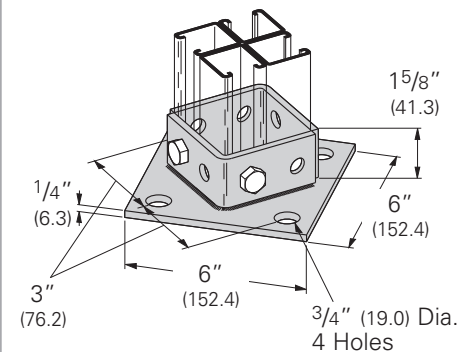

Reference page 106 for general fitting and standard finish specifications.

B570A Post Base for Four Channel Combinations

- Standard finishes: ZN, GRN
- Wt./C 550 Lbs. (249.5 kg)

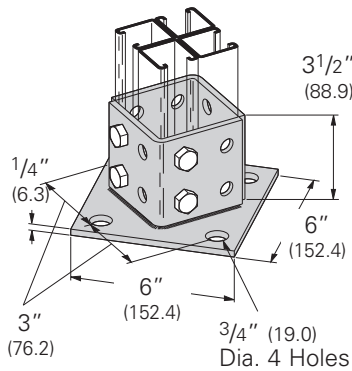

B278 Post Base for B22

- Standard finishes: ZN, GRN
- Wt./C 288 Lbs. (130.6 kg)

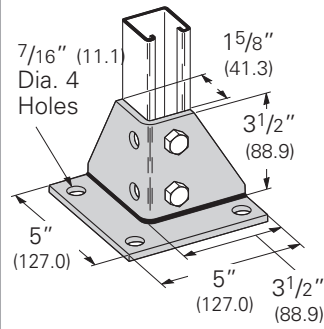

B585 Post Base for B22A

- Standard finishes: ZN, GRN
- Wt./C 97 Lbs. (44.0 kg)

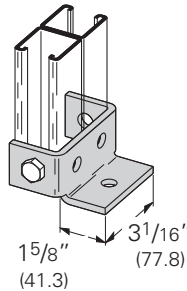

B300 Post Base

- Material: Malleable Iron
- Standard finishes: ZN, GRN
- Wt./C 259 Lbs. (117.5 kg)

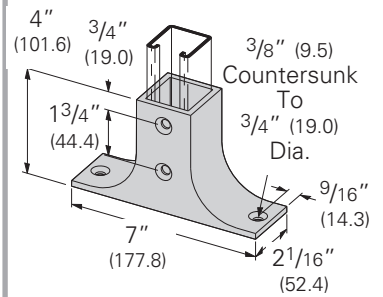

B187 Bracket

- Uniform Loading 1450 Lbs. (6.45 kN)
- Safety Factor of 2.5
- Hole Spacing on Bracket Top 5 5/16 inch (150.8) Center to Center
- Standard finishes: ZN, GRN
- Wt./C 193 Lbs. (87.5 kg)

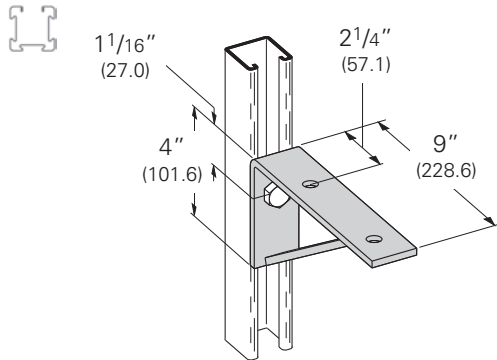

B188 Bracket

- Uniform Loading 1080 Lbs. (4.80 kN)
- Safety Factor of 2.5
- Hole Spacing on Bracket Top 8 15/16 inch (227.0) Center to Center
- Standard finishes: ZN, GRN
- Wt./C 241 Lbs. (109.3 kg)

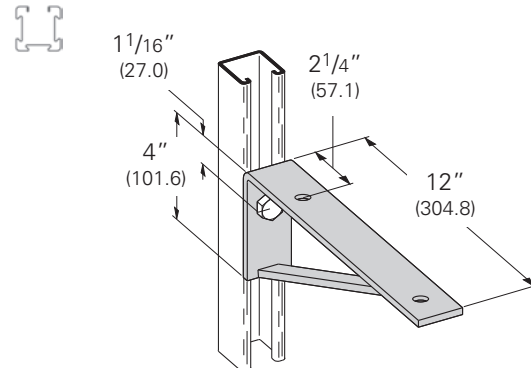

B189 Bracket

- Uniform Loading 870 Lbs. (3.87 kN)
- Safety Factor of 2.5
- Hole Spacing on Bracket Top 11 15/16 inch (303.2) Center to Center
- Standard finishes: ZN, GRN
- Wt./C 308 Lbs. (139.7 kg)

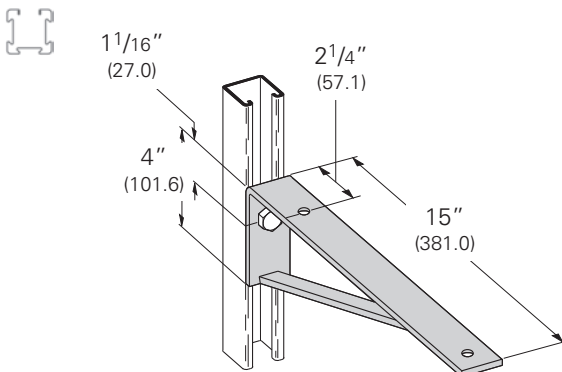

B541 Bracket

- Uniform Loading 1240 Lbs. (5.51 kN)
- Safety Factor of 2.5
- Hole Spacing on Bracket Top 7 7/16 inch (188.9) Center to Center
- Standard finishes: ZN, GRN
- Wt./C 201 Lbs. (91.2 kg)

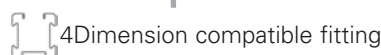
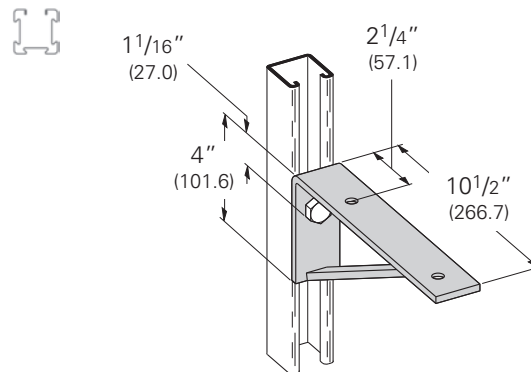

Reference page 106 for general fitting and standard finish specifications.

Post Bases & Brackets

B190 12" (304.8) Bracket

- Uniform Loading 900 Lbs. (4.00 kN)
- Safety Factor of 2.5
- Standard finishes: ZN, GRN
- Wt./C 260 Lbs. (117.9 kg)

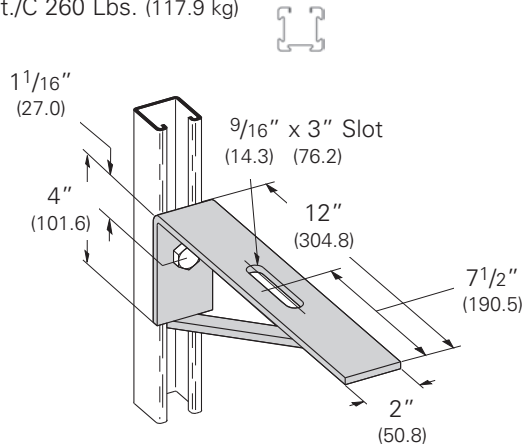

B191-18 18" (457.2) Bracket

- Uniform Loading 600 Lbs. (2.67 kN)
- Safety Factor of 2.5
- Standard finishes: ZN, GRN
- Wt./C 377 Lbs. (171.0 kg)

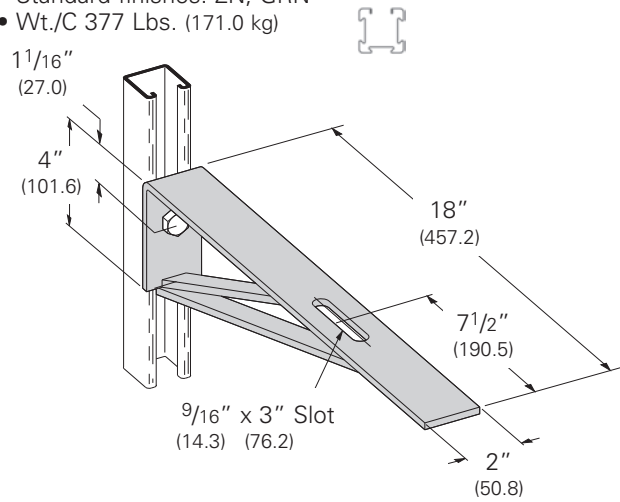

B289-12 12 1/2" (317.5) Bracket

- Uniform Loading 1040 Lbs. (4.63 kN)
- Safety Factor of 2.5
- Standard finishes: ZN, GRN
- Wt./C 285 Lbs. (129.3 kg)

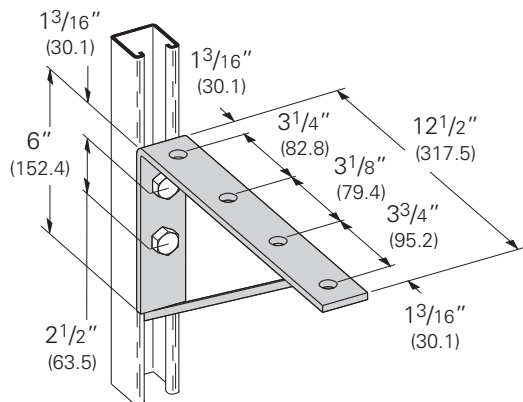

B191-24 24" (609.6) Bracket

- Uniform Loading 450 Lbs. (2.00 kN)
- Safety Factor of 2.5
- Standard finishes: ZN, GRN
- Wt./C 377 Lbs. (171.0 kg)

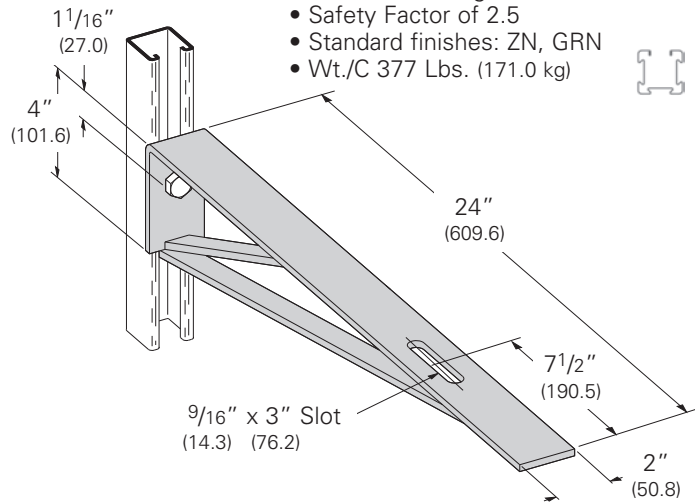

B290 16 1/2" (419.1) Bracket

- Uniform Loading 1200 Lbs. (5.34 kN)
- Safety Factor of 2.5
- Standard finishes: ZN, GRN
- Wt./C 405 Lbs. (183.7 kg)

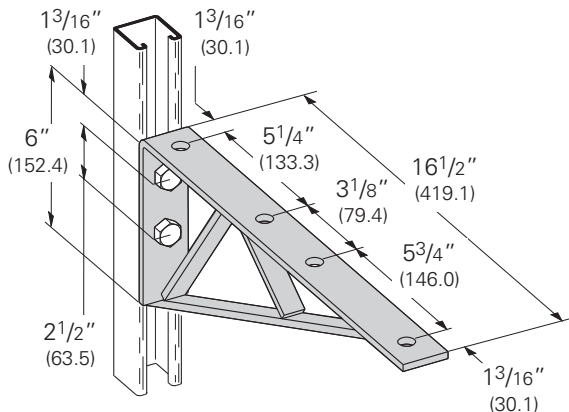

B192 24" (609.6) Bracket

- Uniform Loading 820 Lbs. (3.65 kN)
- Safety Factor of 2.5
- Standard finishes: ZN, GRN
- Wt./C 576 Lbs. (261.3 kg)

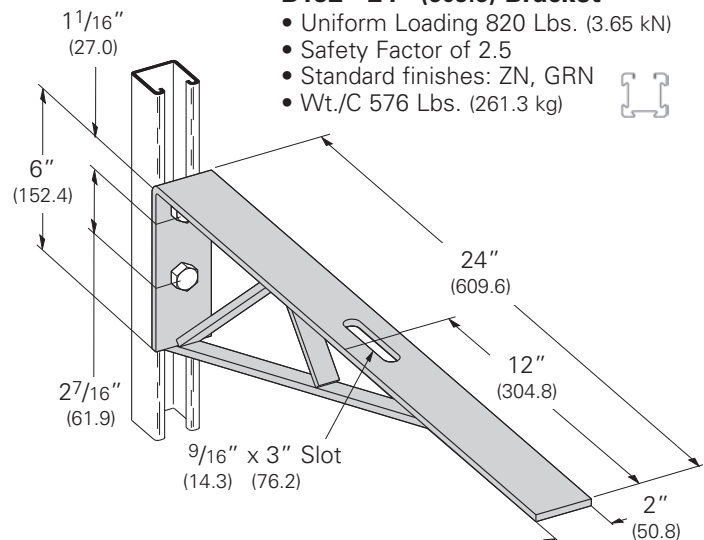

Reference page 106 for general fitting and standard finish specifications.

B289-14 14 1/2" (368.3) Bracket

- Uniform Loading 900 Lbs. (4.00 kN)
- Safety Factor of 2.5
- Standard finishes: ZN, GRN
- Wt./C 295 Lbs. (133.8 kg)

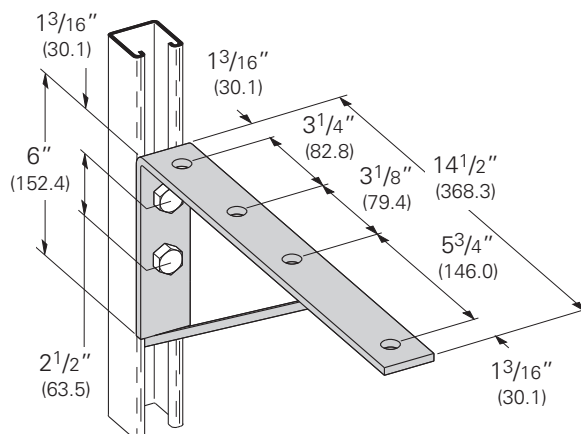

B291 18 1/2" (469.9) Bracket

- Uniform Loading 1070 Lbs. (4.76 kN)
- Safety Factor of 2.5
- Standard finishes: ZN, GRN
- Wt./C 468 Lbs. (212.3 kg)

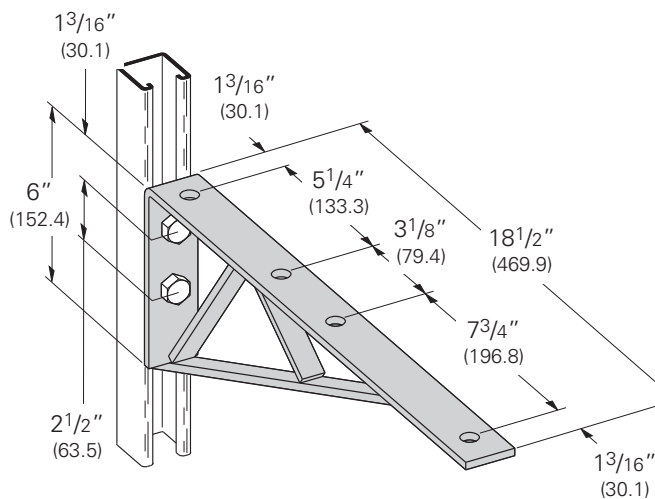

B292 20 1/2" (520.7) Bracket

- Uniform Loading 600 Lbs. (2.67 kN)
- Safety Factor of 2.5
- Standard finishes: ZN, GRN, HDG, SS4
- Wt./C 490 Lbs. (222.2 kg)

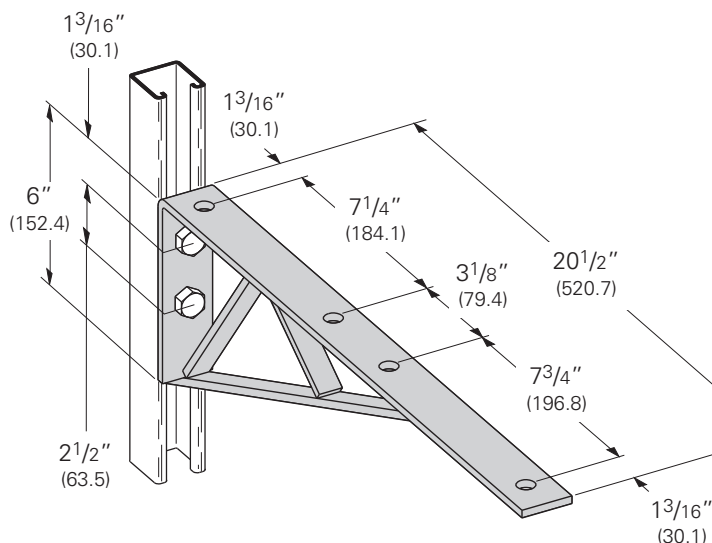

4Dimension compatible fitting

Reference page 106 for general fitting and standard finish specifications.

Brackets

B409 Single Channel Bracket

- Safety Factor of 2.5
- Standard finishes: ZN, GRN, SS4



Part No.	A		Uniform Load		Wt./C	
	In.	mm	Lbs.	kN	Lbs.	kg
B409-6	6"	(152.4)	1920	(8.54)	152	(68.9)
B409-9	9"	(228.6)	1280	(5.69)	195	(88.4)
B409-12	12"	(304.8)	960	(4.27)	232	(105.2)
B409-14	14"	(355.6)	800	(3.56)	274	(124.3)
B409-16	16"	(406.4)	730	(3.25)	314	(142.4)
B409-18	18"	(457.2)	640	(2.84)	347	(157.4)
B409-24	24"	(609.6)	480	(2.13)	450	(204.1)

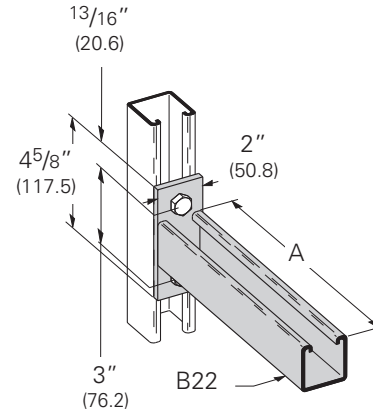

B297 Double Channel Bracket

- Safety Factor of 2.5
- Standard finishes: ZN, GRN, HDG



Part No.	A		Uniform Load		Wt./C	
	In.	mm	Lbs.	kN	Lbs.	kg
B297-12	12"	(304.8)	1660	(7.37)	485	(220.0)
B297-18	18"	(457.2)	1100	(4.88)	668	(303.0)
B297-24	24"	(609.6)	835	(3.71)	857	(388.7)
B297-30	30"	(762.0)	665	(2.95)	1040	(471.7)
B297-36	36"	(914.4)	550	(2.44)	1240	(562.4)
B297-42	42"	(1066.8)	465	(2.06)	1440	(653.2)

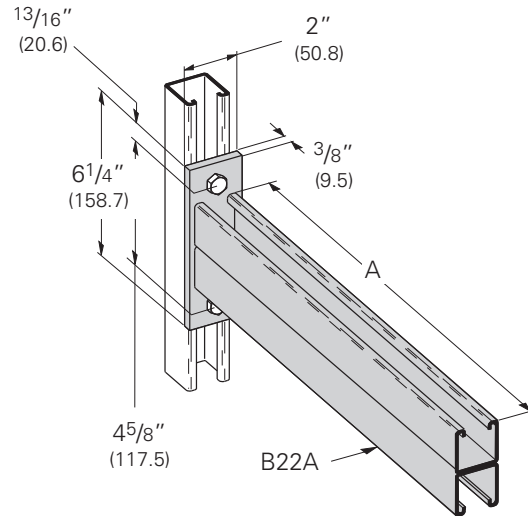

B494 Braced Single Bracket

- Safety Factor of 2.5
- Standard finishes: ZN, GRN



Part No.	L		H		Uniform Load		Wt. /C	
	In.	mm	In.	mm	Lbs.	kN	Lbs.	kg
B494-12	12"	(304.8)	8 ³ / ₄ "	(222.2)	2500	(11.12)	392	(178.0)
B494-18	18"	(475.2)	8 ³ / ₄ "	(222.2)	1700	(7.56)	509	(231.0)
B494-24	24"	(609.6)	8 ³ / ₄ "	(222.2)	1300	(5.78)	635	(288.0)
B494-30	30"	(762.0)	11 ¹ / ₄ "	(285.7)	1600	(7.11)	885	(402.8)
B494-36	36"	(914.4)	11 ¹ / ₄ "	(285.7)	1100	(4.89)	1024	(464.5)
B494-42	42"	(1066.8)	16"	(406.4)	980	(4.36)	1285	(582.9)
B494-48	48"	(1219.2)	16"	(406.4)	980	(4.36)	1409	(639.1)

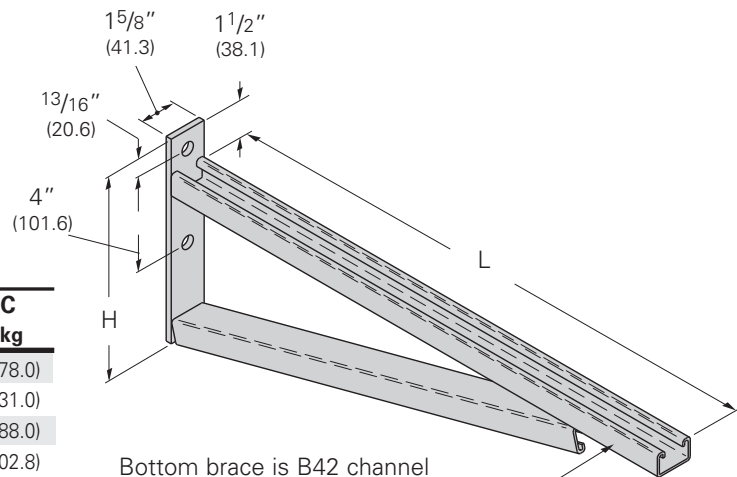

Bottom brace is B42 channel on B494-24 and smaller and B22 channel on B494-30 and larger

4Dimension compatible fitting

Reference page 106 for general fitting and standard finish specifications.

B174SH-B186SH L&R Slotted Bracket

- Safety Factor of 2.5
- Specify L for left or R for right bracing
- Material: ASTM A1011 33,000 PSI min. yield
- Standard finishes: ZN, GRN

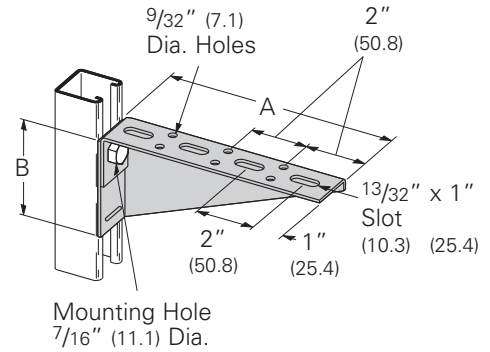

Mounting Hole
7/16" (11.1) Dia.

Right bracket shown, left bracket gussett on opposite side.

Part No.	A		B		Uniform Load		Wt./C	
	In.	mm	In.	mm	Lbs.	kN	Lbs.	kg
B174SH	24"	(609.6)	67/16"	(163.5)	225	(1.00)	370	(167.8)
B175SH	26"	(660.4)	615/16"	(176.2)	225	(1.00)	425	(192.8)
B176SH	28"	(711.2)	77/16"	(188.9)	225	(1.00)	480	(217.7)
B177SH	30"	(762.0)	715/16"	(201.6)	225	(1.00)	520	(235.9)
B178SH	12"	(304.8)	37/16"	(87.3)	350	(1.55)	143	(64.8)
B179SH	14"	(355.6)	315/16"	(100.0)	350	(1.55)	162	(73.5)
B180SH	16"	(406.4)	47/16"	(112.7)	250	(1.11)	204	(92.5)
B181SH	18"	(457.2)	415/16"	(125.4)	250	(1.11)	232	(105.2)
B182SH	20"	(508.0)	57/16"	(138.1)	250	(1.11)	275	(124.7)
B183SH	22"	(558.8)	515/16"	(150.8)	250	(1.11)	317	(143.8)
B184SH	6"	(152.4)	115/16"	(49.2)	225	(1.00)	58	(26.3)
B185SH	8"	(203.2)	27/16"	(61.9)	225	(1.00)	82	(37.2)
B186SH	10"	(254.0)	215/16"	(74.6)	325	(1.44)	103	(46.7)

B196 Channel Clevis Bracket

- Safety Factor of 2.5
- Standard finishes: ZN, GRN

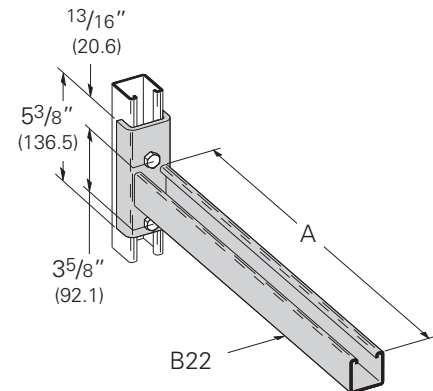

Part No.	A		Uniform Load		Wt./C	
	In.	mm	Lbs.	kN	Lbs.	kg
B196-18	18"	(457.2)	600	(2.67)	430	(195.0)
B196-24	24"	(609.6)	450	(2.00)	510	(231.3)

B198 Channel Clevis Bracket

- Safety Factor of 2.5
- Standard finishes: ZN, GRN

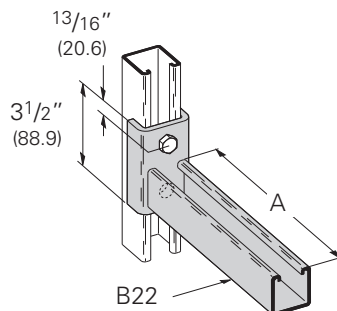

Part No.	A		Uniform Load		Wt./C	
	In.	mm	Lbs.	kN	Lbs.	kg
B198-6	6"	(152.4)	1600	(7.12)	185	(83.9)
B198-12	12"	(304.8)	800	(3.56)	284	(128.8)

B198A Channel Clevis Bracket

- Safety Factor of 2.5
- Standard finishes: ZN, GRN

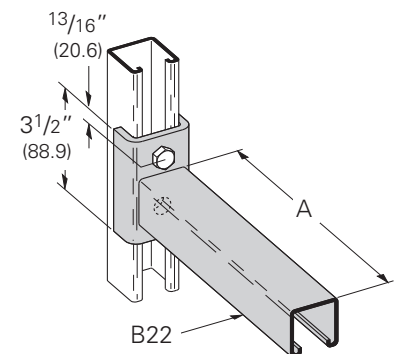

Part No.	A		Uniform Load		Wt./C	
	In.	mm	Lbs.	kN	Lbs.	kg
B198A-6	6"	(152.4)	1600	(7.12)	185	(83.9)
B198A-12	12"	(304.8)	800	(3.56)	284	(128.8)

4Dimension compatible fitting

Reference page 106 for general fitting and standard finish specifications.

Brackets

B293 Channel Bracket

- Safety Factor of 2.5
- Standard finishes: ZN, GRN

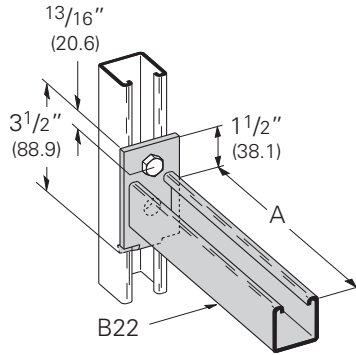

Part No.	A		Uniform Load		Wt./C	
	In.	mm	Lbs.	kN	Lbs.	kg
B293-6	6"	(152.4)	1200	(5.34)	144	(65.3)
B293-12	12"	(304.8)	600	(2.67)	252	(114.3)
B293-18	18"	(457.2)	400	(1.78)	340	(154.2)
B293-24	24"	(609.6)	300	(1.33)	412	(186.9)

B293A Channel Bracket

- Safety Factor of 2.5
- Standard finishes: ZN, GRN

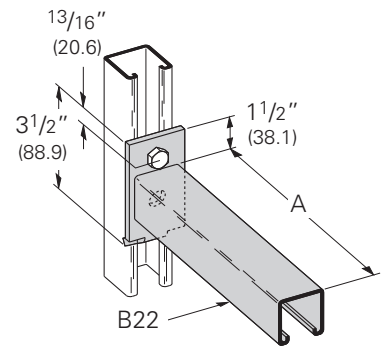

Part No.	A		Uniform Load		Wt./C	
	In.	mm	Lbs.	kN	Lbs.	kg
B293A-6	6"	(152.4)	1200	(5.34)	144	(65.3)
B293A-12	12"	(304.8)	600	(2.67)	252	(114.3)
B293A-18	18"	(457.2)	400	(1.78)	340	(154.2)
B293A-24	24"	(609.6)	300	(1.33)	412	(186.9)

B194 Bracket for B22 & B24

- Safety Factor of 2.5
- 6300 In.-Lbs (712 N•m) applies to fitting only, not to strength of strut arm
- Refer to pages 56, 57 & 59 for strut loading data
- Standard finishes: ZN, GRN
- Wt./C 210 Lbs. (95.2 kg)

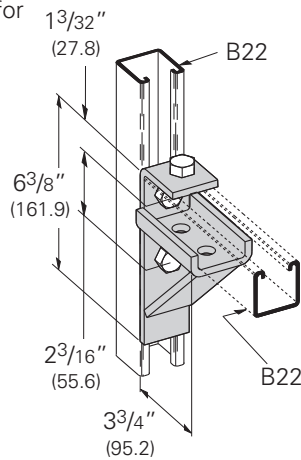

B370 Bracket for B22A & B11

- Safety Factor of 2.5
- 13000 In.-Lbs (1469 N•m) applies to fitting only, not to strength of strut arm
- Refer to pages 51, 56, & 57 for strut loading data
- Standard finishes: ZN, GRN
- Wt./C 266 Lbs. (120.6 kg)

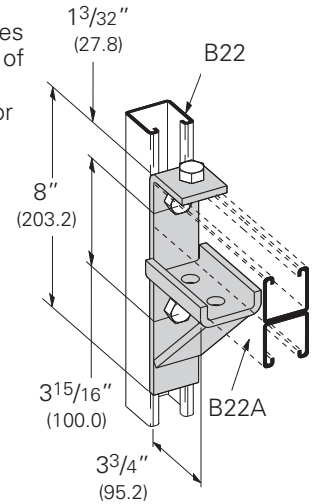

B195 Bracket for B42

- Safety Factor of 2.5
- 2500 In.-Lbs (282 N•m) applies to fitting only, not to strength of strut arm
- Refer to pages 57 & 65 for strut loading data
- Standard finishes: ZN, GRN
- Wt./C 174 Lbs. (78.9 kg)

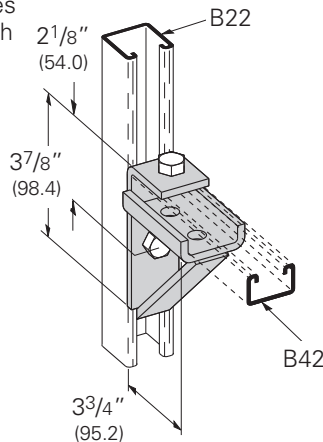

B440 Bracket for B52 & B54

- Safety Factor of 2.5
- 2000 In.-Lbs (226 N•m) applies to fitting only, not to strength of strut arm
- Refer to page 57, 67, & 69 for strut loading data
- Standard finishes: ZN, GRN
- Wt./C 177 Lbs. (80.3 kg)

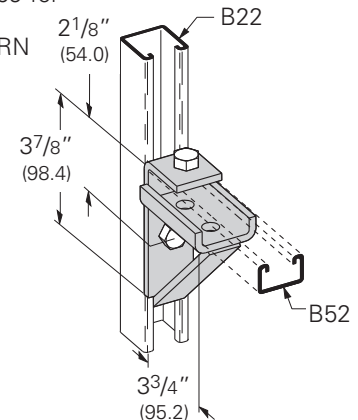

4Dimension compatible fitting

Reference page 106 for general fitting and standard finish specifications.

B449-4, 8 & 12 Cable Saddle Bracket

- Safety Factor of 2.5
- Material: 11 Gauge (3.0) ASTM A1011 HSLAS Gr. 50
- Standard finishes: ZN, GRN



Part No.	A		B		Uniform Load		Wt./C	
	In.	mm	In.	mm	Lbs.	kN	Lbs.	kg
B449-4	4 ¹ / ₂ "	(114.3)	2 ³ / ₈ "	(60.3)	2400	(10.67)	74	(33.5)
B449-8	8 ¹ / ₂ "	(215.9)	2 ³ / ₈ "	(60.3)	1270	(5.65)	124	(56.2)
B449-12	12 ¹ / ₂ "	(317.5)	4"	(101.6)	860	(3.82)	184	(83.4)

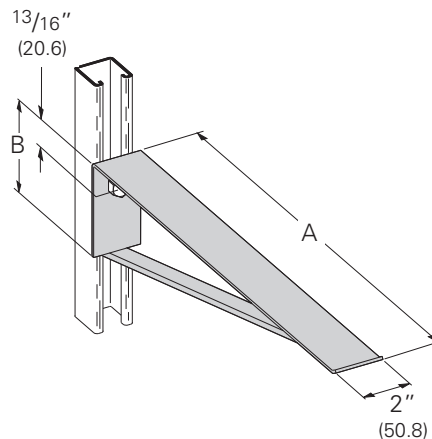

B449-18 18" (457.2) Cable Saddle Bracket

- Safety Factor of 2.5
- Uniform Load 960 Lbs. (4.17 kN)
- Material: 11 Gauge (3.0) ASTM A1011 HSLAS Gr. 50
- Standard finishes: ZN, GRN
- Wt./C 312 Lbs. (141.5 kg)

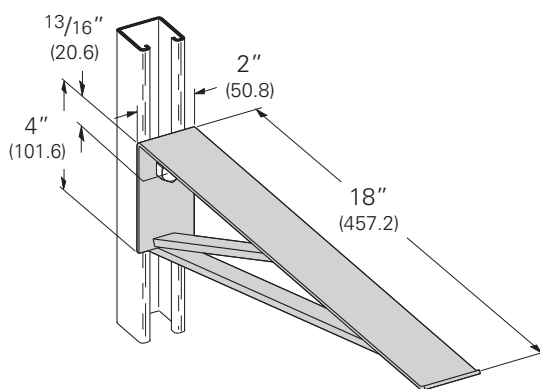

B409DB Series Solar Bracket

- Safety Factor of 2.5
- Includes: (1) Channel Bracket Plate - 1/4" x 3 1/2" x 7 3/4" with welded channel
(1) Back Plate - 1/4" x 3 1/2" x 7 3/4"
(4) 3/8"-16 x 8 1/2" Square Neck Carriage Bolts
(4) 3/8"-16 Serrated Flange Hex Nuts
- Fits 4" (101mm) to 6 1/2" (165mm) wide supports
- Standard finishes: ZN, HDG

Part No.	L		Uniform Load		Wt./C	
	In.	mm	Lbs.	kN	Lbs.	kg
B409DB-12	12"	(304.8)	800	(3.56)	766	(347.4)
B409DB-18	18"	(457.2)	800	(3.56)	956	(433.6)

A single channel version and other lengths are available. Contact Eaton B-Line Division engineering for more information.

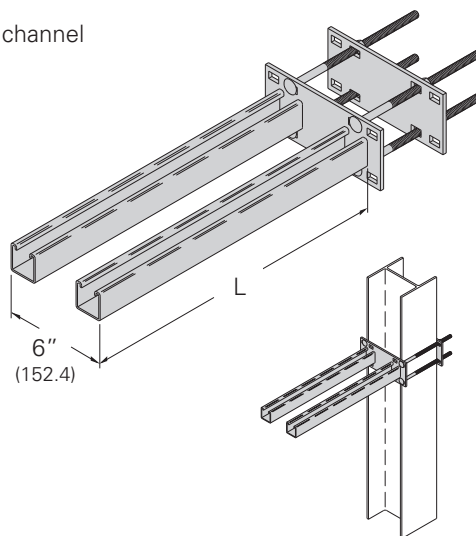

Reference page 106 for general fitting and standard finish specifications.

Brackets

B816

- Standard finishes: ZN, HDG

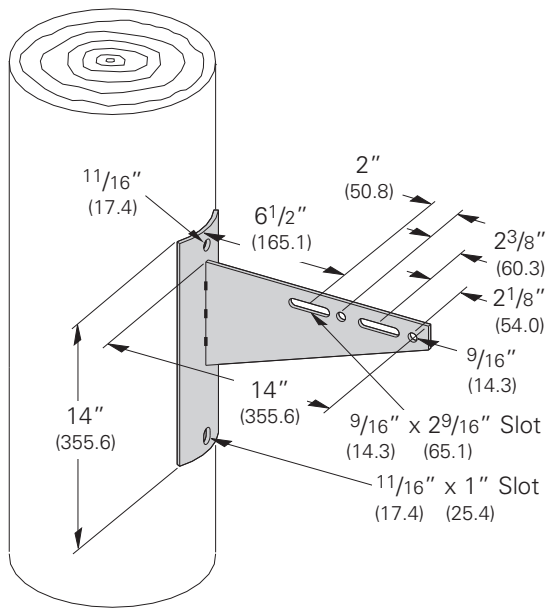

B852S-*.***

- *Specify Width: W = 8, 12, 16
- **Specify Depth: D = 6, 8, 10, 12, 16, 18, 24
- $13\frac{1}{16}$ " (20.6mm) x 1 " (25.4mm) banding slots for steel band
- Standard finishes: ZN, HDG

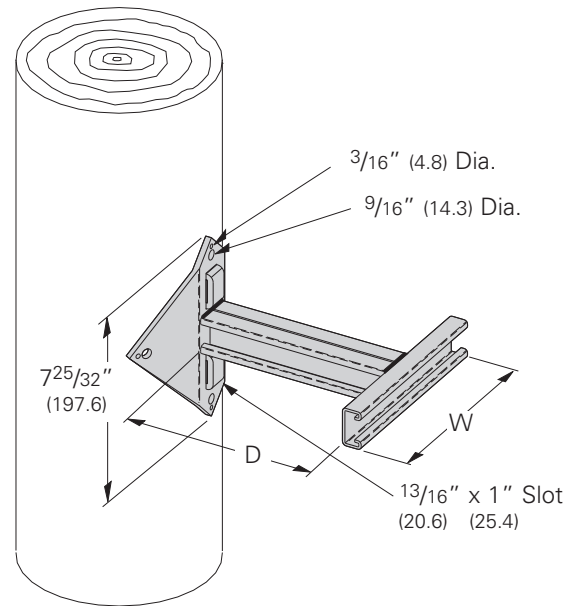

B802D-*

- *Specify Width: W = 8, 12, 16
- Standard finishes: ZN, HDG

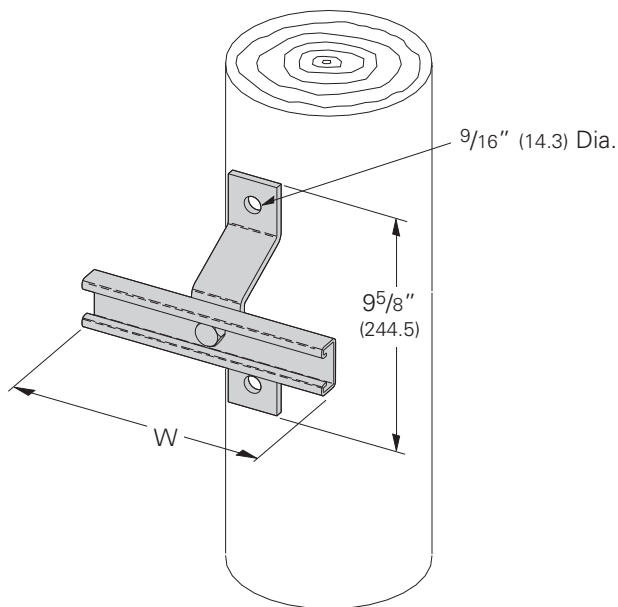

B810-*

- *Specify Width: W = 8, 12, 16
- $13\frac{1}{16}$ " (20.6mm) x 1 " (25.6mm) banding slots for steel band
- Standard finishes: ZN, HDG

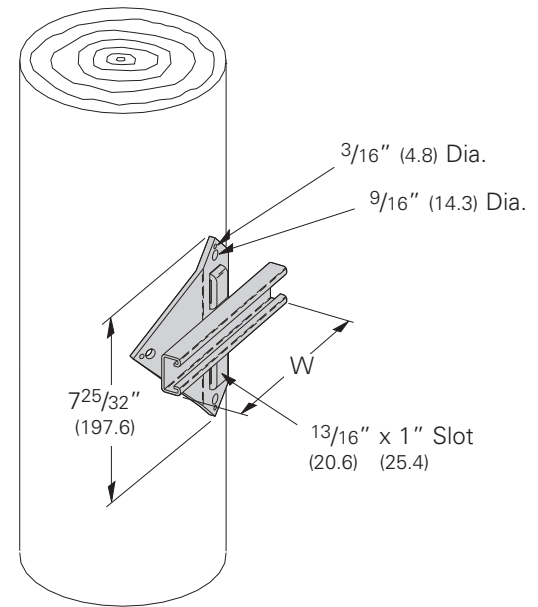

Reference page 106 for general fitting and standard finish specifications.

B811-*

- *Specify Width: W = 8, 12, 16
- Can be attached directly to B809 & B812
- Standard finishes: ZN, HDG

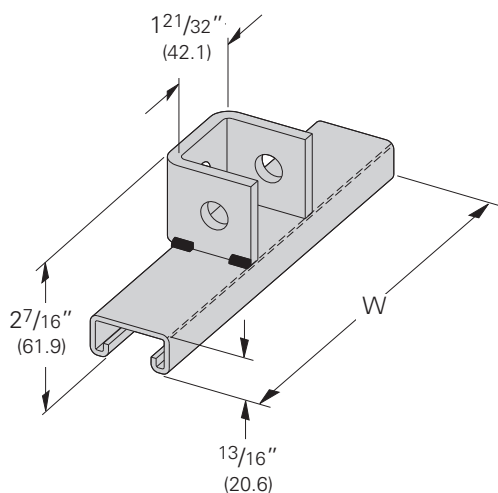

B812-*

- *Specify Depth: D = 6, 8, 12, 16, 18, 24
- 13/16" (20.6mm) x 1" (25.4mm) banding slots for steel band
- Standard finishes: ZN, HDG

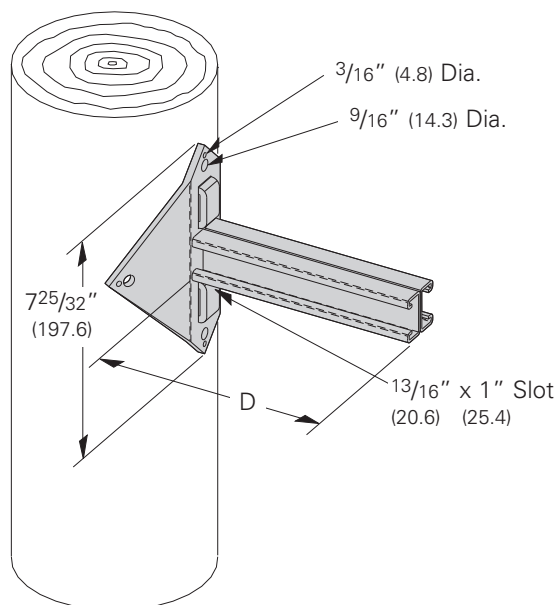

B809B-*

- *Specify Depth: D = 6, 8, 10, 12, 16, 18, 24
- 13/16" (20.6mm) x 1" (25.4mm) banding slots for steel band
- Standard finishes: ZN, HDG

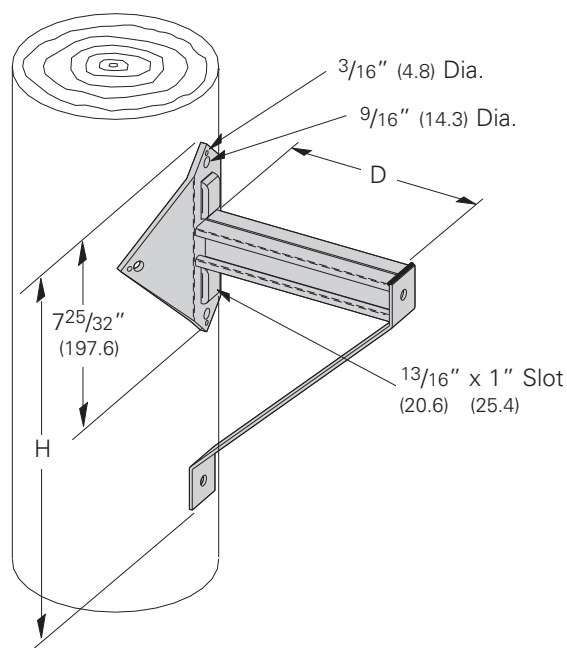

Part No.	D		H	
	In.	mm	In.	mm
B809B-6	6"	(152.4)	12 ³ / ₄ "	(323.9)
B809B-8	8"	(203.2)	14 ³ / ₄ "	(374.7)
B809B-10	10"	(254.0)	16 ³ / ₄ "	(425.5)
B809B-12	12"	(304.8)	18 ³ / ₄ "	(476.2)
B809B-16	16"	(406.4)	22 ³ / ₄ "	(577.8)
B809B-18	18"	(457.2)	24 ³ / ₄ "	(628.6)
B809B-24	24"	(609.6)	27 ³ / ₄ "	(704.8)

Reference page 106 for general fitting and standard finish specifications.

Miscellaneous Fittings

B214 R&L Reel Rack Support for 1 1/4" (32) Pipe

- Standard finishes: ZN, GRN
- Wt./C 200 Lbs. (90.7 kg)

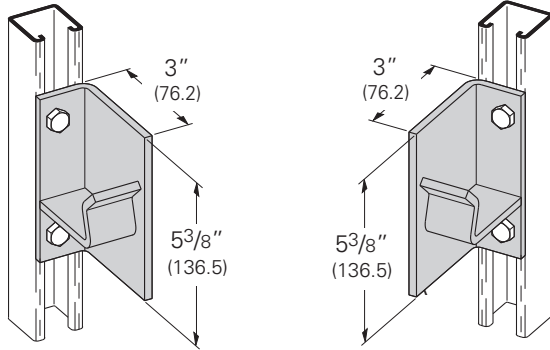

B214R
Right Hand

B214L
Left Hand

B514 R&L Reel Rack Support for 2" (50) Pipe

- Standard finishes: ZN, GRN
- Wt./C 246 Lbs. (111.6 kg)

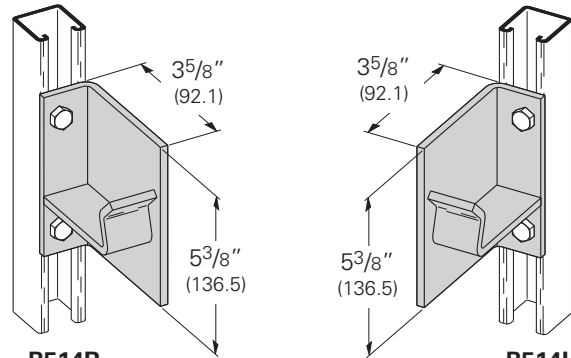

B514R
Right Hand

B514L
Left Hand

B475 Double Reel Rack Support on Single Channel for 1 1/4" (32) Pipe

- Standard finishes: ZN, GRN
- Wt./C 326 Lbs. (147.9 kg)

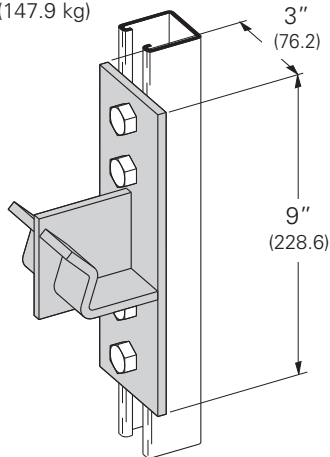

B473 Double Reel Rack Support on Single Channel for 2" (50) Pipe

- Standard finishes: ZN, GRN
- Wt./C 351 Lbs. (159.2 kg)

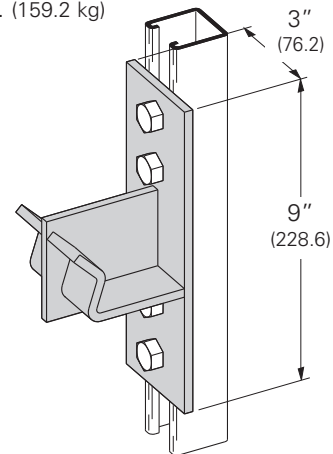

B474 Double Reel Rack Support on Double Channel for 1 1/4" (32) Pipe

- Standard finishes: ZN, GRN
- Wt./C 257 Lbs. (116.6 kg)

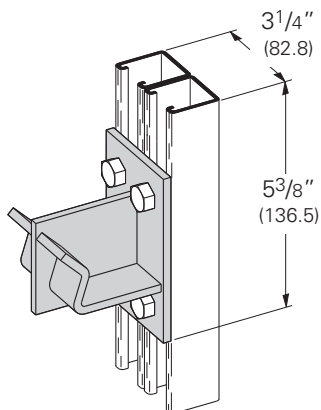

B472 Double Reel Rack Support on Double Channel for 2" (50) Pipe

- Standard finishes: ZN, GRN
- Wt./C 299 Lbs. (135.6 kg)

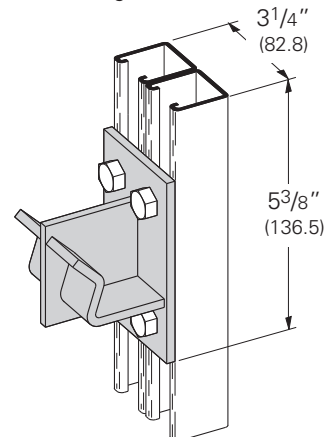

4Dimension compatible fitting

Reference page 106 for general fitting and standard finish specifications.

B438 Pipe Support Bracket

- Standard finishes: ZN, GRN
- Material: ASTM A36
- Wt./C 132 Lbs. (59.9 kg)

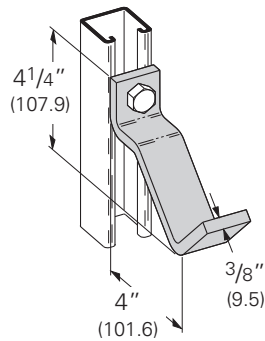

B439 Pipe Support Bracket

- Standard finishes: ZN, GRN
- Wt./C 88 Lbs. (39.9 kg)

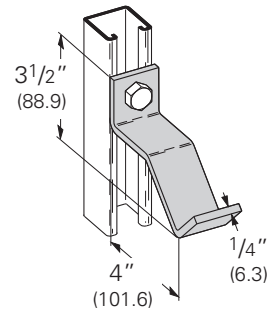

B411 Series Ladder Rungs

- Standard finishes: ZN, GRN

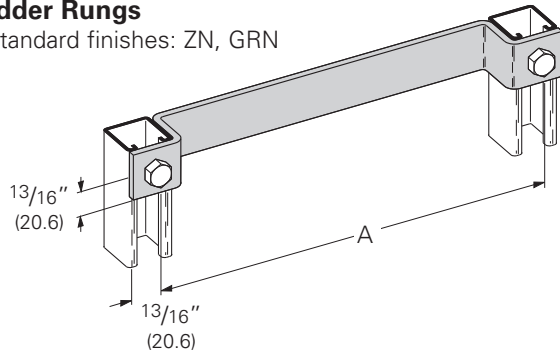

Part No.	A		Wt./C	
	In.	mm	Lbs.	kg
B411-12	12"	(304.8)	176	(79.8)
B411-15	15"	(381.0)	202	(91.6)
B411-18	18"	(457.2)	234	(106.1)

B381-B385 Wall Ladder Brackets

- Standard finishes: ZN, GRN

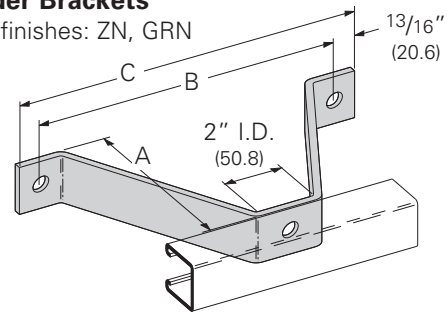

Part No.	A		B		C		Wt./C	
	In.	mm	In.	mm	In.	mm	Lbs.	kg
B381	2 ³ / ₈ "	(60.3)	6"	(152.4)	7 ⁵ / ₈ "	(193.7)	110	(49.9)
B382	4 ³ / ₈ "	(111.1)	8"	(203.2)	9 ⁵ / ₈ "	(244.5)	164	(74.4)
B383	6 ³ / ₈ "	(161.9)	10"	(254.0)	11 ⁵ / ₈ "	(295.3)	200	(90.7)
B384	8 ³ / ₈ "	(212.7)	12"	(304.8)	13 ⁵ / ₈ "	(346.1)	253	(114.7)
B385	10 ³ / ₈ "	(263.5)	14"	(355.6)	15 ⁵ / ₈ "	(396.9)	318	(144.2)

B587-1/2, 3/4 & 1 Pipe Coupling Fitting

- Safety Factor of 2.5
- Standard finishes: ZN, GRN

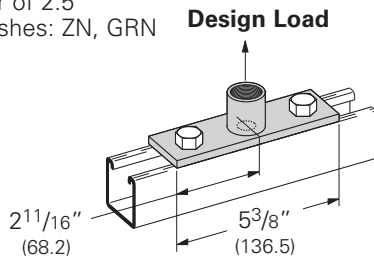

Part No.	For Pipe Size		Wt./C		Design Load
	In.	mm	Lbs.	kg	Lbs. kN
B587-1/2	1/2"	(15)	77	(34.9)	1000 (4.45)
B587-3/4	3/4"	(20)	84	(38.1)	1400 (6.23)
B587-1	1"	(25)	105	(47.6)	1900 (8.45)



4Dimension compatible fitting

Reference page 106 for general fitting and standard finish specifications.

Miscellaneous Fittings

B349 Trolley Beam Support

- Design Load 1200 Lbs. (5.34 kN)
- Safety Factor of 2.5
- Use $\frac{3}{8}$ " x 3" bolts in side hole to clamp strut together (not included)
- Standard finishes: ZN, GRN
- Wt./C 107 Lbs. (48.5 kg)

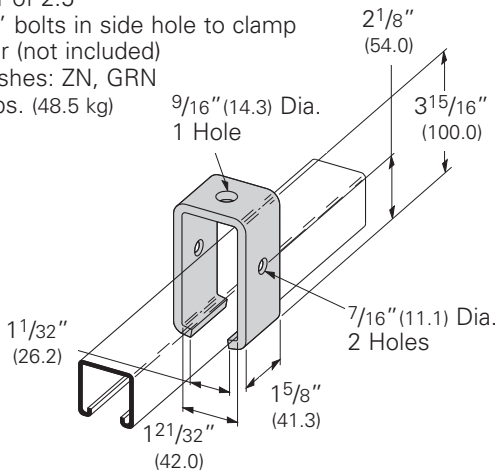

B350 Trolley Beam Joint Support

- Design Load 1200 Lbs. (5.34 kN)
- Use $\frac{3}{8}$ " x 3" bolts in side hole to clamp strut together (not included)
- Standard finishes: ZN, GRN
- Wt./C 233 Lbs. (105.7 kg)

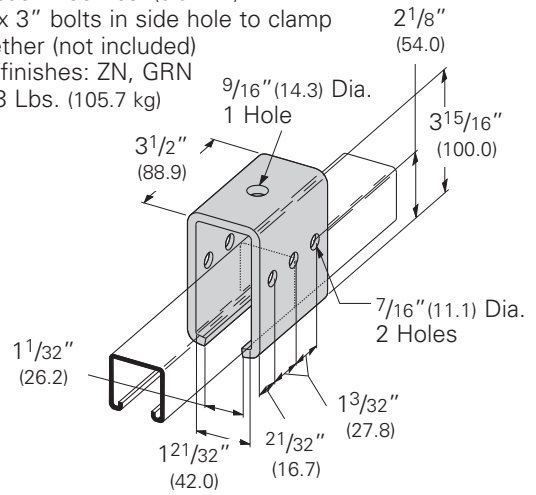

B614 Column Support for B22

- Quick installation (one bolt to tighten)
- Design Load 800 Lbs. (3.56 kN) Slip with Safety Factor of 3
- Use with B22 and B24 Channel
- Sold in pairs
- Standard finish: ZN
- Wt./C 50 Lbs. (22.6 kg)

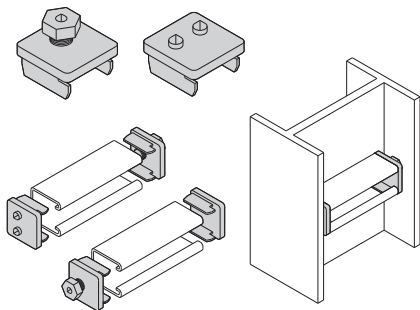

B613 Column Support for B22

- Design Load 800 Lbs. (3.56 kN) Slip with Safety Factor of 3
- Use with B22 and B24 Channel
- Setscrews to be torqued to 19 ft./Lbs
- Sold in pairs
- Standard finishes: ZN, GRN, HDG
- Wt./C 100 Lbs. (45.3 kg)

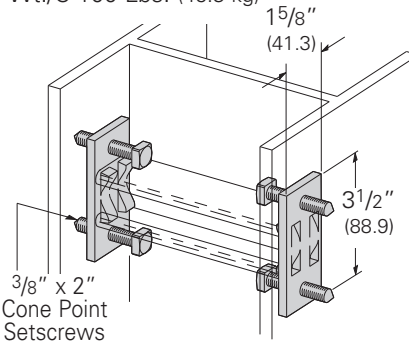

B613A Column Support for B52

- Design Load 800 Lbs. (3.56 kN) Slip with Safety Factor of 3
- Use with B52 and B54 Channel
- Setscrews to be torqued to 19 ft./Lbs
- Sold in pairs
- Standard finishes: ZN, GRN, HDG
- Wt./C 100 Lbs. (45.3 kg)

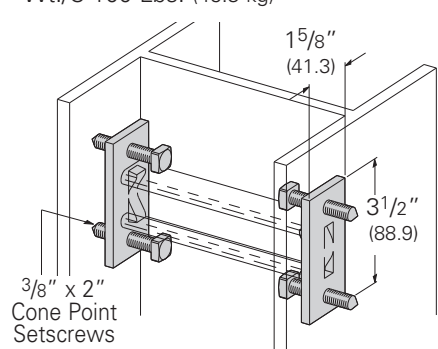

B560 45° Stair Support

- Standard finishes: ZN, GRN
- Wt./C 220 Lbs. (99.8 kg)

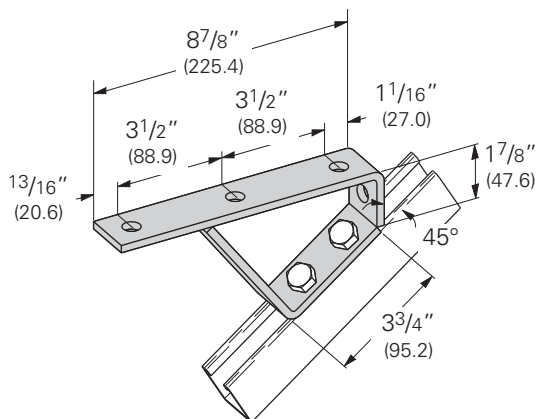

B562 37 1/2° Stair Support

- Standard finishes: ZN, GRN
- Wt./C 206 Lbs. (93.4 kg)

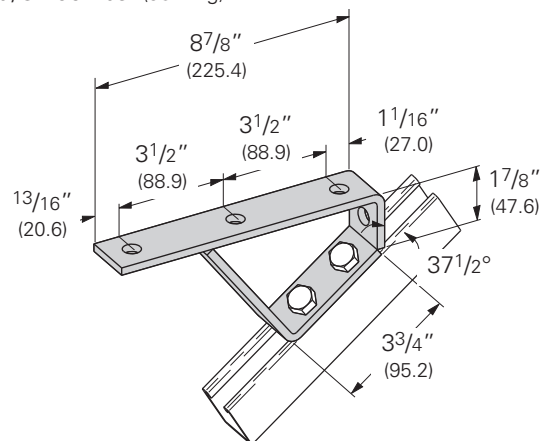

Reference page 106 for general fitting and standard finish specifications.

B376 Four Bearing Trolley Assembly

- Safety Factor of 2.5
- Stainless steel ball bearings
- Not for continuous cycling applications
- Standard finishes: ZN
- Wt./C 110 Lbs. (49.9 kg)

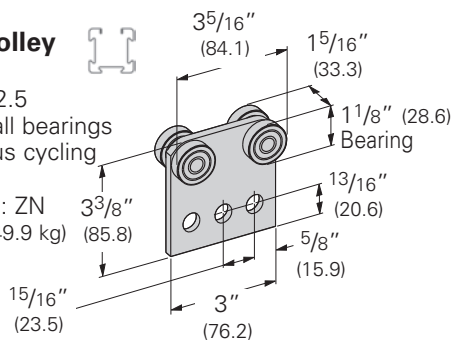

Design Load in B22		
Lbs.	kN	RPM
300	(1.33)	@600
450	(2.00)	@300
600	(2.67)	@100

Design Load

B377 Two Bearing Trolley Assembly

- Safety Factor of 2.5
- Stainless steel ball bearings
- Not for continuous cycling applications
- Standard finishes: ZN
- Wt./C 48 Lbs. (21.8 kg)

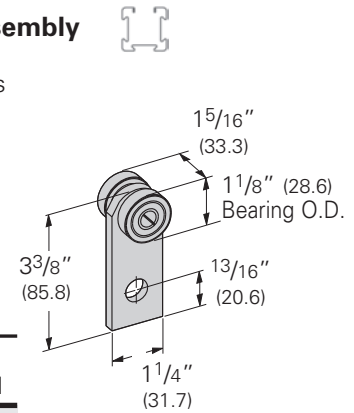

Design Load in B22		
Lbs.	kN	RPM
150	(.67)	@600
225	(1.00)	@300
437	(1.94)	@100

Design Load

B477 Two Bearing Light Duty Trolley Assembly

- Design Load 50 Lbs. (.22 kN)
- Safety Factor of 2.5
- Stainless steel ball bearings
- Not for continuous cycling applications
- Material: 12 Gauge (2.6) ASTM A1011 33,000 PSI min. yield
- Standard finishes: ZN
- Wt./C 30 Lbs. (13.6 kg)

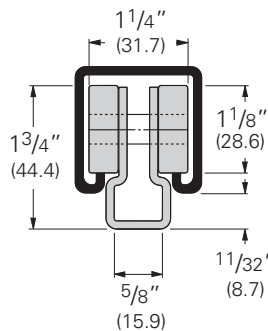

B477P With Plastic Bearings

- Design Load 10 Lbs. (.045 kN)

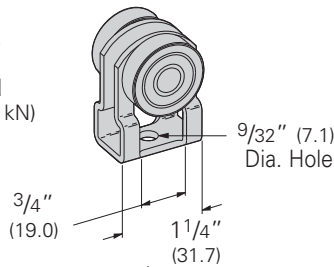

Design Load

B478 Four Bearing Light Duty Trolley Assembly

- Design Load 100 Lbs. (.44 kN)
- Safety Factor of 2.5
- Stainless steel ball bearings
- Not for continuous cycling applications
- Material: 12 Gauge (2.6) ASTM A1011 33,000 PSI min. yield
- Standard finishes: ZN
- Wt./C 68 Lbs. (30.8 kg)

B478P With Plastic Bearings

- Design Load 20 Lbs. (.090 kN)

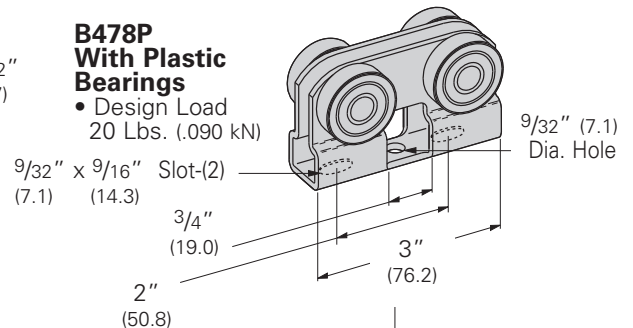

Design Load

B477H Two Bearing Light Duty Trolley Assembly with Eye Hook

- Design Load 50 Lbs. (.22 kN)
- Safety Factor of 2.5
- Stainless steel ball bearings
- Not for continuous cycling applications
- Material: 12 Gauge (2.6) ASTM A1011 33,000 PSI min. yield
- Standard finishes: ZN
- Wt./C 36 Lbs. (16.3 kg)

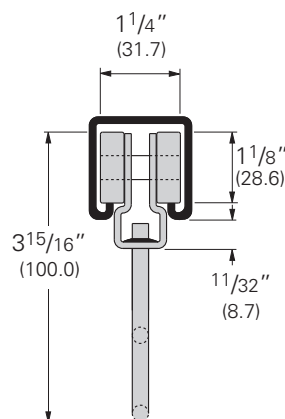

B477HP With Plastic Bearings

- Design Load 10 Lbs. (.045 kN)

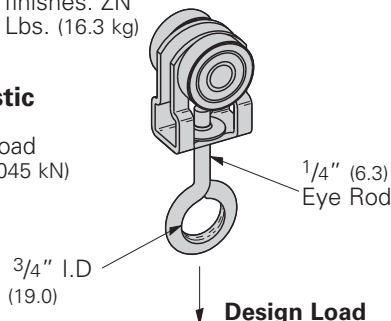

Design Load

B478H Four Bearing Light Duty Trolley Assembly with Eye Hook

- Design Load 100 Lbs. (.44 kN)
- Safety Factor of 2.5
- Stainless steel ball bearings
- Not for continuous cycling applications
- Material: 12 Gauge (2.6) ASTM A1011 33,000 PSI min. yield
- Standard finishes: ZN
- Wt./C 72 Lbs. (32.6 kg)

B478HP With Plastic Bearings

- Design Load 20 Lbs. (.090 kN)

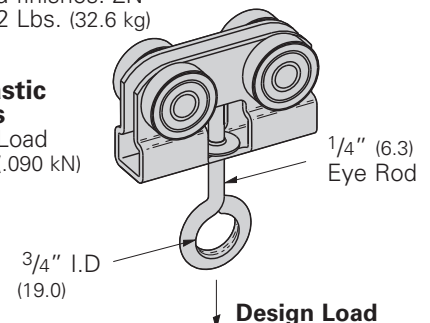

Design Load

4Dimension compatible fitting

Reference page 106 for general fitting and standard finish specifications.

Miscellaneous Fittings

B203-B206 & B220-B223 Channel End Caps Type X

- Material: ASTM A1011 CS Type B
- Standard finishes: ZN, GRN, HDG, SS4, AL

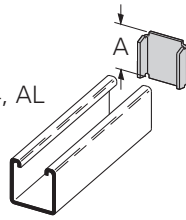

Part No.	Use With	A		Wt./C	
		In.	mm	Lbs.	kg
B203	B42	1.015	(25.8)	6	(2.7)
B204	B54	.827	(21.0)	5	(2.2)
B205	B22	1.640	(41.6)	10	(4.5)
B206	B32	1.390	(35.3)	8	(3.6)
B220	B52	.827	(21.0)	4	(1.8)
B221	B12	2.452	(62.3)	15	(6.8)
B222	B11	3.265	(82.9)	20	(9.1)
B223	B24	1.640	(41.6)	10	(4.5)

B283-B286 Channel End Caps

- Material: ASTM A1011 33,000 PSI min. yield
- Standard finishes: ZN, GRN

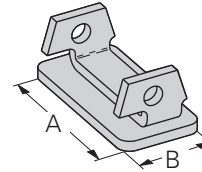

Part No.	Use With	A		B		Wt./C	
		In.	mm	In.	mm	Lbs.	kg
B283	B52	1 ¹⁹ / ₃₂ "	(40.5)	2 ⁵ / ₃₂ "	(19.8)	6	(2.7)
B284	B54	1 ¹⁹ / ₃₂ "	(40.5)	2 ⁵ / ₃₂ "	(19.8)	6	(2.7)
B285	B22	1 ¹⁹ / ₃₂ "	(40.5)	1 ¹⁹ / ₃₂ "	(40.5)	13	(5.9)
B286	B24	1 ¹⁹ / ₃₂ "	(40.5)	1 ¹⁹ / ₃₂ "	(40.5)	14	(6.3)

B287 & B288 Channel End Caps

- Material: ASTM A1011 33,000 PSI min. yield
- Standard finishes: ZN, GRN

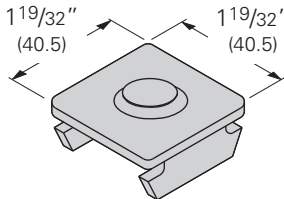

Part No.	Use With	Wt./C	
		Lbs.	kg
B287	B22	13	(5.9)
B288	B24	14	(6.3)

B3322, B3332, B3342, B3352 Anchor End Caps Type Y

- Material: ASTM A1011 33,000 PSI min. yield
- Standard finishes: ZN

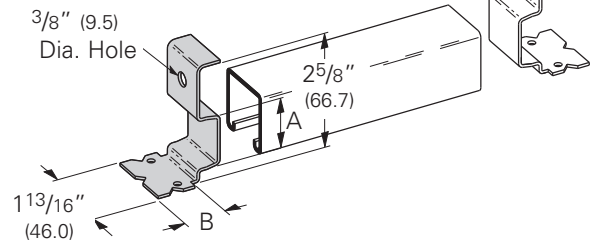

Part No.	Use With	A		B		Wt./C	
		In.	mm	In.	mm	Lbs.	kg
B3322	B22I	1.270	(32.2)	1 ³ / ₁₆ "	(30.2)	15	(6.8)
B3332	B32I	1.000	(25.4)	1 ³ / ₁₆ "	(30.2)	15	(6.8)
B3342	B42I	.645	(16.4)	1 ¹ / ₄ "	(31.8)	15	(6.8)
B3352	B52I	.460	(11.7)	1 ⁵ / ₁₆ "	(33.3)	15	(6.8)

B822 Plastic End Cap for B22 & B24

- Material: Polyvinyl Chloride (PVC/Vinyl)
- Withstands intermittent temperatures up to 350°F (177°C) and 200°F (93°C) continuous
- Wt./C 3 Lbs. (1.3 kg)
- Available in colors: White (W), Yellow (Y), Black (BLK), Gray (GRY),

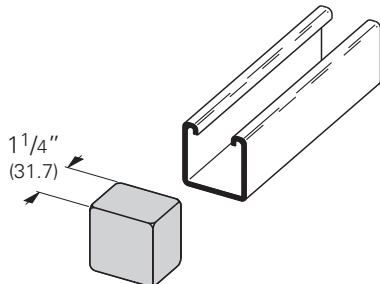

B822A Plastic End Cap for B22A & B11

- Material: Polyvinyl Chloride (PVC/Vinyl)
- Withstands intermittent temperatures up to 350°F (177°C) and 200°F (93°C) continuous
- Wt./C 5 Lbs. (2.2 kg)
- Available in colors: White (W), Yellow (Y), Black (BLK), Gray (GRY), Green (GRN)

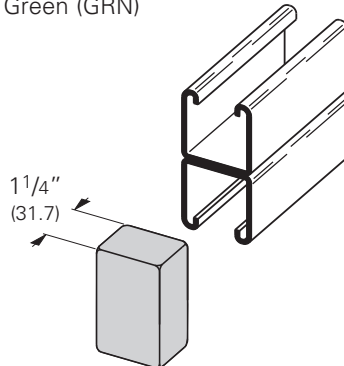

B852 Plastic End Cap for B52 & B54

- Material: Polyvinyl Chloride (PVC/Vinyl)
- Withstands intermittent temperatures up to 350°F (177°C) and 200°F (93°C) continuous
- Wt./C 2.5 Lbs. (1.1 kg)
- Available in colors: White (W), Yellow (Y), Black (BLK), Gray (GRY), Green (GRN)

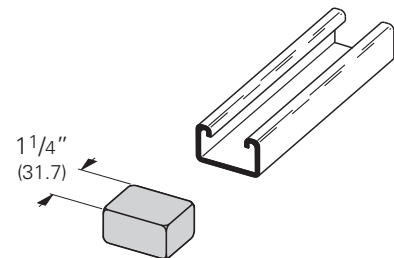

Reference page 106 for general fitting and standard finish specifications.

B823 Profile End Caps

- Material: Polyvinyl Chloride (PVC/Vinyl)
- Withstands intermittent temperatures up to 350°F (177°C) and 200°F (93°C) continuous
- Available in colors: White (W), Yellow (Y), Black (BLK), Gray (GRY), Green (GRN)

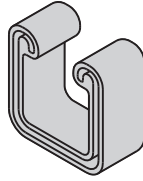

Approx. 3/4" deep
(19.0)

Part No.	Fits Channel Sizes	Wt./C	
		Lbs.	kg
B823-22A	B22A, B24A, B26A	6.9	(3.1)
B823-22	B22, B24, B26	4.1	(1.8)
B823-42	B42	3.8	(1.7)
B823-52	B52, B54, B56	3.5	(1.6)

B825 Plastic End Caps

- Material: Polyurethane
- Available in colors: Gray (GRY), Green (GRN)

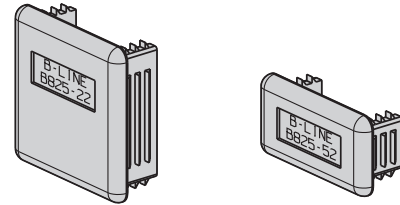

Part No.	Fits Channel Sizes	Wt./C	
		Lbs.	kg
B825-22	B22 & B24	2.0	(0.9)
B825-52	B52 & B54	1.0	(0.4)

B408SLBVNS Series Stand-Off Brackets

- Material: 1/4" (6.3)
- Standard Finishes: HDG, ZN, GRN
- For pipe or rigid conduit sizes of 1 1/2" (40) and 2" (50) use with B501 Series 'U'-Bolts (see page 53)
- For strut channels 1 5/8" (41.3) wide use with B500 Series Square 'U'-Bolts (see page 53)
- Hardware is not included

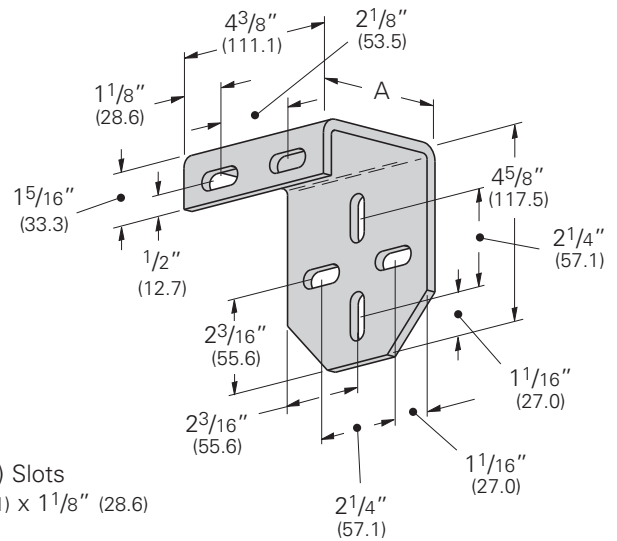
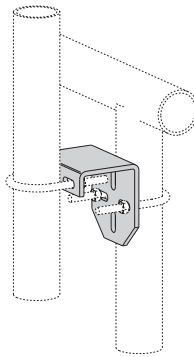

Part No.	A In. (mm)	Wt./C	
		Lbs.	kg
B408SLBVNS	3 1/2" (88.9)	189	(85.7)
B408SLBVNS1	3" (76.2)	220	(99.8)
B408SLBVNS2	2" (50.8)	236	(107.0)

Reference page 106 for general fitting and standard finish specifications.

Beam Clamps



Our beam attachments and pipe supports offered in this section are designed to provide supports without drilling or welding. A complete selection of beam clamps, pipe clamps, rollers, supports and accessories are designed for use with our channels and offer many installation advantages.

Materials & Finishes (Unless otherwise noted)

Pipe clamps, pipe hangers, beam clamps, brackets, and rollers are made from low carbon steel strips, plates or rod unless noted.

Note: A minimum order may apply on special material and finishes.

Load Data

The load data published includes a safety factor of 5.0 unless noted (safety factor = ratio of ultimate load to the design load).

Recommended Torque For Setscrews (unless noted)

See chart on page 106 for recommended torquing of bolts (not setscrews).

Metric

Metric dimensions are shown in parentheses. Unless noted, all metric dimensions are in millimeters.

Finish Code	Finish	Specification
PLN	Plain	ASTM A1018 Gr. 33 ASTM A1011 SS Grade 33
ZN	Electro-Plated Zinc	ASTM B633 SC3 Type III or ASTM A653
GRN	DURA GREEN™	
-	Malleable Iron	ASTM A47 Gr. 32510
HDG	Hot-Dipped Galvanized	ASTM A123
CZ	Chromium Zinc	ASTM F1136 Gr. 3
SS4	Stainless Steel Type 304	ASTM A240
SS6	Stainless Steel Type 316	ASTM A240
AL	Aluminum	ASTM B209

Setscrew Size	1/4"-20	3/8"-16	1/2"-13
ft-lbs	4	5	11
Nm	5	7	15

Setscrew Size	5/8"-11	3/4"-10
ft-lbs	21	34
Nm	28	46

B351L Steel C-Clamp with Locknut

- Safety Factor of 5
- Setscrew and locknut included
- When Retaining Strap is required, order B3362, B3363 or B3365 separately
- Standard finishes: ZN, SS4, PLN

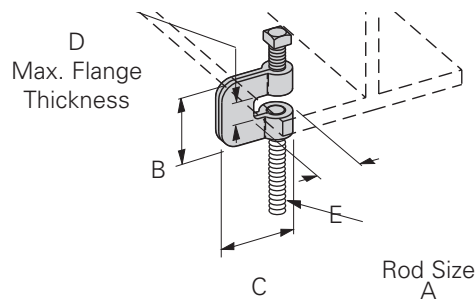

Part Number With Locknut	Rod Size A	B		C		D		E		Design Load		Wt./C	
		In.	mm	In.	mm	In.	mm	In.	mm	Lbs.	kN	Lbs.	kg
B351L-3/8 *	3/8"-16	2 3/8"	(60.3)	2 3/8"	(60.3)	3/4"	(19.0)	1 3/8"	(34.9)	230	(1.03)	41	(18.6)
B351L-1/2 *	1/2"-13	2 3/8"	(60.3)	2 3/8"	(60.3)	3/4"	(19.0)	1 3/8"	(34.9)	380	(1.71)	41	(18.6)
B351L-5/8 *	5/8"-11	2 3/8"	(60.3)	2 1/4"	(57.1)	3/4"	(19.0)	1 3/8"	(34.9)	550	(2.47)	60	(27.2)
B351L-3/4 *	3/4"-10	2 3/8"	(60.3)	3 1/4"	(82.5)	3/4"	(19.0)	1 3/8"	(34.9)	630	(2.83)	71	(32.2)
B351L-7/8	7/8"-9	3"	(76.2)	3 1/4"	(82.5)	1"	(25.4)	1 7/8"	(47.6)	1200	(5.34)	184	(83.4)

B3036L C-Clamp with Locknut

- Safety Factor of 5
- When Retaining Strap is required, order B3363 or B3364 separately
- Setscrew and locknut included
- Material: Malleable iron
- Standard finishes: ZN, PLN

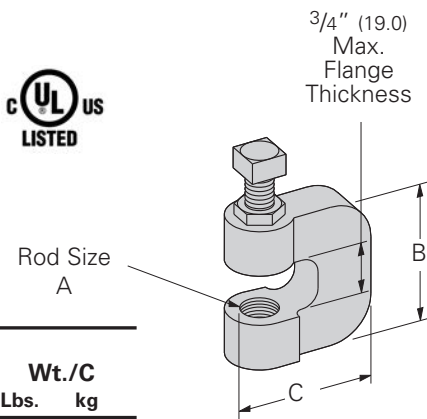

Part Number With Locknut	Rod Size A	B		C	Design Load		Wt./C		
		In.	mm		Lbs.	kN	Lbs.	kg	
B3036L-3/8	3/8"-16	1 3/4"	(44.4)	1 3/4"	(44.4)	300	(0.89)	29	(13.1)
B3036L-1/2	1/2"-13	1 3/4"	(44.4)	1 3/4"	(44.4)	380	(1.69)	28	(12.7)
B3036L-5/8	5/8"-11	2"	(50.8)	1 7/8"	(47.6)	530	(2.36)	55	(24.9)
B3036L-3/4	3/4"-10	2"	(50.8)	2"	(50.8)	530	(2.36)	72	(32.6)

B3362 thru B3365 Retaining Strap

- † When ordering specify L (Length) as a suffix to the part number
- Material: 14 gauge (1.9)
- Standard finishes: GALV, SS4

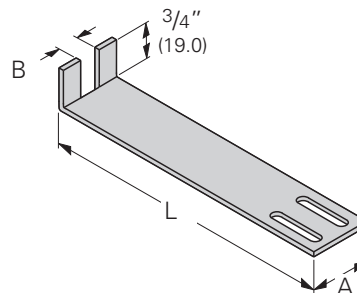

Part No.	Wt./C for Length L of				A	B	For Use With
	6" (152.4)	8" (203.2)	10" (254.0)	12" (304.8)			
	Lbs. kg	Lbs. kg	Lbs. kg	Lbs. kg	In. mm	In. mm	
B3362†	17 (7.7)	24 (10.9)	31 (14.0)	38 (17.2)	1 1/4" (31.7)	7/16" (11.1)	B351-3/8 & 1/2
B3363†	16 (7.2)	23 (10.4)	30 (13.6)	37 (16.8)	1 1/4" (31.7)	5/8" (15.9)	B351-5/8 & 3/4 B3036-3/8 & 1/2
B3364†	16 (7.2)	23 (10.4)	30 (13.6)	37 (16.8)	1 1/4" (31.7)	1 1/16" (17.4)	B3036-5/8 & 3/4
B3365†	21 (9.5)	29 (13.1)	37 (16.8)	46 (20.8)	1 1/2" (38.1)	3/4" (19.0)	B351-7/8

† See note above.

Reference page 154 for general fitting and standard finish specifications.

Beam Clamps

B3033 Reversible Wide Jaw Wedge C-Clamp (Malleable Iron)

- Safety Factor of 5
- Setscrew and locknut included
- Material: Malleable iron
- Standard finishes: HDG with ZN hardware, PLN



Throat Openings
 1 1/4" (31.7) For
 3/8 & 1/2 Sizes
 1 5/16" (33.3) For
 5/8 & 3/4 Sizes

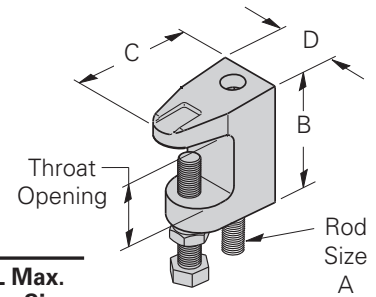

Part No.	Rod Size A	B		C		D		Design Load		Wt./C		UL Max. Pipe Size	
		In.	mm	In.	mm	In.	mm	Lbs.	kN	Lbs.	kg	In.	mm
B3033-3/8	3/8"-16	2 1/4"	(57.1)	2"	(50.8)	1 1/8"	(28.6)	500	(2.22)	46	(20.8)	4"	(100)
B3033-1/2	1/2"-13	2 5/16"	(58.7)	2 3/16"	(55.5)	1 1/4"	(31.7)	810	(3.60)	64	(29.0)	8"	(200)
B3033-5/8	5/8"-11	2 5/8"	(66.7)	2 1/2"	(63.5)	1 3/8"	(34.9)	1000	(4.48)	116	(52.6)	8"	(200)
B3033-3/4	3/4"-10	2 11/16"	(68.3)	2 1/2"	(63.5)	1 7/16"	(36.5)	1400	(6.22)	140	(63.5)	10"	(250)

B3034 Wedge C-Clamp

- Safety Factor of 5
- 3/4" (19.0) Max. flange thickness
- Setscrew and locknut included
- Material: Malleable iron
- Standard finishes: HDG with ZN hardware, PLN

Note:
 3/8" & 1/2" Sizes
 Are Reversible
 Style



*
 3/8 & 1/2
 Sizes Only

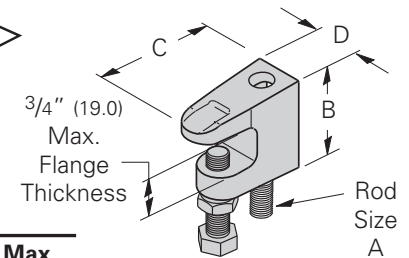

Part No.	Rod Size A	B		C		D		Design Load		Wt./C		UL Max. Pipe Size	
		In.	mm	In.	mm	In.	mm	Lbs.	kN	Lbs.	kg	In.	mm
B3034-3/8*	3/8"-16	1 5/8"	(41.3)	2"	(50.8)	7/8"	(22.2)	560	(2.49)	54	(24.5)	4"	(100)
B3034-1/2*	1/2"-13	1 13/16"	(46.0)	2 3/16"	(55.5)	1 3/16"	(30.2)	810	(3.60)	51	(23.1)	8"	(200)
B3034-5/8	5/8"-11	1 3/4"	(44.5)	2 1/8"	(54.0)	1 1/8"	(28.6)	1000	(4.48)	70	(31.7)	-	-
B3034-3/4	3/4"-10	2"	(50.8)	2 1/4"	(57.2)	1 1/8"	(28.6)	1500	(6.67)	98	(44.4)	-	-

Fig. 69 (Formally B-Line B3367) Retaining Strap

- Specify 'L' lengths required
- Minimum recommended return on strap is 1" (25.4)
- Material: Pre-Galvanized Steel
- Standard finishes: GALV

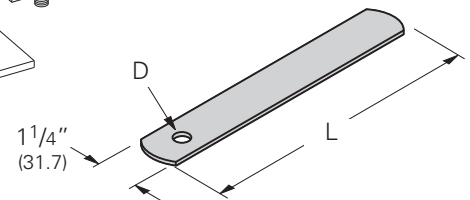
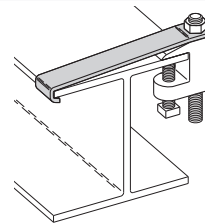

Part No.	Hole Dia. D		For Use	Wt./C**
	In.	mm		
69-3/8-L	7/16"	(30.1)	B3033-3/8, B3034-3/8 & 65XT-3/8	23.9 (10.8)
69-1/2-L	9/16"	(30.1)	B3033-1/2 & B3034-1/2	23.6 (10.7)
69-5/8-L	11/16"	(50.8)	B3033-5/8	23.2 (10.5)
69-3/4-L	13/16"	(63.5)	B3033-3/4	22.7 (10.3)

** Wt./C based on 6" (152.4) length.
 For each additional inch in strap
 length add 4.2 Lbs (1.9 kg) to Wt./C.

Fig. 69R Retrofit Retaining Strap

- Specify 'L' lengths required
- Minimum recommended return on strap is 1" (25.4)
- Material: Pre-Galvanized Steel
- Standard finishes: GALV

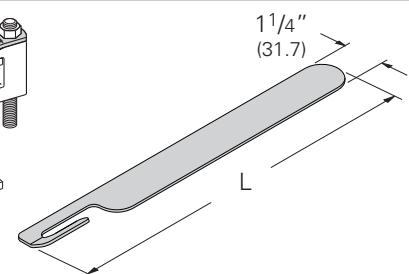
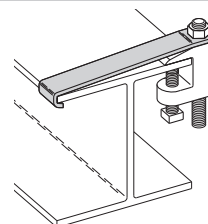

Part No.	Slot Width		For Use	Wt./C**
	In.	mm		
69R-3/8-L	7/16"	(30.1)	B3033-3/8, B3034-3/8 & 65XT-3/8	22.9 (10.4)
69R-1/2-L	9/16"	(30.1)	B3033-1/2 & B3034-1/2	22.6 (10.2)

** Wt./C based on 6" (152.4) length.
 For each additional inch in strap
 length add 4.2 Lbs (1.9 kg) to Wt./C.

Reference page 154 for general fitting and standard finish specifications.

Fig. 65XT Reversible C-Type Beam Clamp

- Safety Factor of 5
- 3/4" (19.0) Max. flange thickness
- Setscrew and locknut included
- Maximum pipe size 4" (100)
- Design Load 610 Lbs. (2.71kN)
- Material: Steel
- Standard finishes: ZN, PLN

Rod Size
3/8"-16

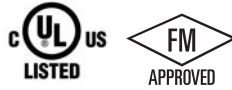
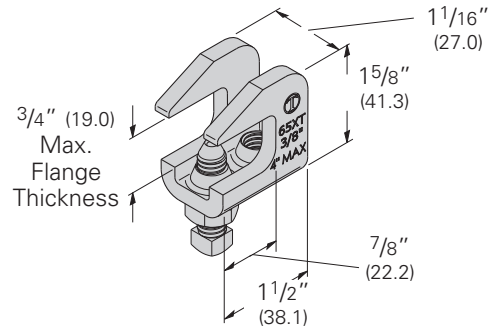

Fig. 65 Reversible Steel C-Type Beam Clamp - 3/4" (19.0mm) Throat Opening

Fig. 66 Reversible Steel C-Type Beam Clamp - 1 1/4" (31.7mm) Throat Opening

- Safety Factor of 5
- Maximum pipe size 4" (100) for 3/8"-16 rods
- Maximum pipe size 8" (100) for 1/2"-13 rods
- Material: Steel
- Standard finishes: ZN, PLN

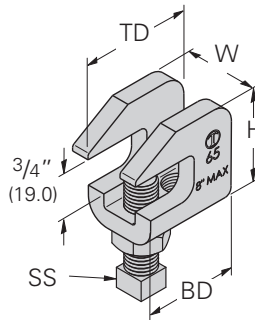

Fig. 65

Setscrews and locknuts included

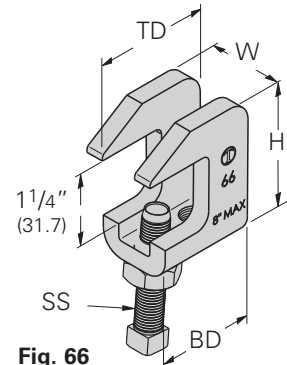

Fig. 66

Part No.	Rod Size	Set Screw SS	TD		BD		H		W		Mac. Rec Load* Lbs. (kN)	Approx. Wt./100 Lbs. (kg)
			in.	(mm)	in.	(mm)	in.	(mm)	in.	(mm)		
65-1/2	1/2"-13	1/2"-13 x 13/4"	1 15/16"	(49.2)	1 5/8"	(41.3)	1 7/8"	(47.6)	1 1/4"	(31.7)	1130 (31.7)	55 (24.9)
65-5/8	5/8"-11	1/2"-13 x 13/4"	1 15/16"	(49.2)	1 5/8"	(41.3)	1 7/8"	(47.6)	1 1/4"	(31.7)	1130 (31.7)	55 (24.9)
66-3/8	3/8"-16	3/8"-16 x 2"	1 1/2"	(38.1)	1 13/32"	(35.7)	2 3/16"	(55.6)	1"	(25.4)	610 (2.71)	28 (12.7)
66-1/2	1/2"-13	1/2"-13 x 2"	2"	(50.8)	1 21/32"	(42.0)	2 7/16"	(61.9)	1 1/4"	(31.7)	1130 (31.7)	55 (24.9)
66-5/8	5/8"-11	1/2"-13 x 13/4"	2"	(50.8)	1 21/32"	(42.0)	2 7/16"	(61.9)	1 1/4"	(31.7)	1130 (31.7)	55 (24.9)

* Maximum loads for clamp with set screw in up or down position.

Fig. 67SS & Fig. 68SS Reversible Stainless Steel C-Type Beam Clamp

- Safety Factor of 5
- Maximum pipe size 4" (100) for 3/8"-16 rods
- Maximum pipe size 8" (100) for 1/2"-13 rods
- Material: Stainless Steel
- Standard finishes: ZN, PLN

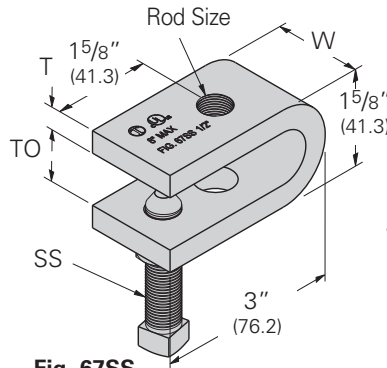

Fig. 67SS

Setscrews and locknuts included

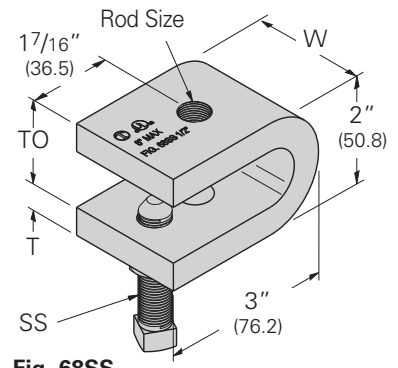

Fig. 68SS

Part No.	Rod Size	Set Screw SS	T		W		TO		Mac. Rec Load* Lbs. (kN)	Approx. Wt./100 Lbs. (kg)
			in.	(mm)	in.	(mm)	in.	(mm)		
67SS-3/8	3/8"-16	3/8"-16 x 1 1/2"	3/8"	(9.6)	1"	(25.4)	7/8"	(22.2)	1500 (6.67)	68 (30.8)
67SS-1/2	1/2"-13	1/2"-13 x 2"	3/8"	(9.6)	1 1/2"	(38.1)	7/8"	(22.2)	4050 (18.0)	107 (48.5)
68SS-3/8	3/8"-16	3/8"-16 x 1 1/2"	3/8"	(9.6)	1 1/2"	(38.1)	1 1/4"	(31.7)	1500 (6.67)	84 (38.1)
68SS-1/2	1/2"-13	1/2"-13 x 2"	1/2"	(12.7)	2"	(50.8)	1"	(25.4)	4050 (18.0)	170 (77.1)

Reference page 154 for general fitting and standard finish specifications.

Beam Clamps

B3037Z Z-Purlin C-Clamp

- Design Load 500 Lbs. (2.22 kN)
- Safety Factor of 5
- Designed for attaching a 3/8"-16 hanger rod to the bottom flange of a Z-purlin
- Setscrew and locknut included
- Material: Malleable iron
- Standard finishes: ZN, PLN

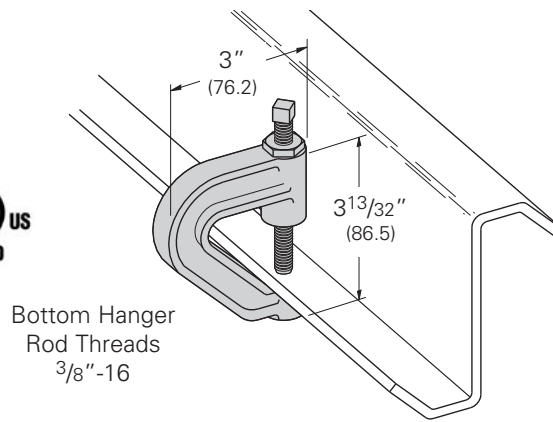

B444 Series Rod Support

- Safety Factor of 5
- Max. flange thickness
3/4" (19.0) for 1/4 & 5/16 sizes
1" (25.4) for 3/8 & 1/2 sizes
- Setscrew included
- Material: Malleable iron
- Standard finish: ZN, available in HDG with CZ Hardware

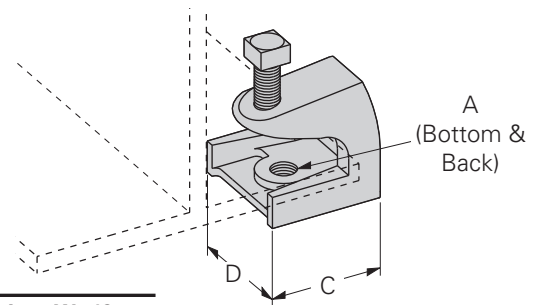

Part No.	Thread Size A	Set Screw	C		D		Design Load		Wt./C	
			In.	mm	In.	mm	Lbs.	kN	Lbs.	kg
B444-1/4	1/4"-20	1/4"-20	1 3/8"	(34.9)	1 3/16"	(30.1)	150	(.66)	24	(10.9)
B444-5/16	5/16"-18	1/4"-20	1 3/8"	(34.9)	1 3/16"	(30.1)	150	(.66)	23	(10.4)
B444-3/8	3/8"-16	1/2"-13	1 7/8"	(47.6)	2"	(50.8)	350	(7.12)	65	(29.5)
B444-1/2	1/2"-13	5/8"-11	2 3/8"	(60.3)	2 1/2"	(63.5)	1000	(4.45)	132	(59.9)

BC442 Light Duty Beam Clamp

- Design Load 75 Lbs. (.33 kN)
- Safety Factor of 5
- 1 1/16" (17.5) Max. flange thickness
- Setscrew included
- Holes tapped 1/4"-20 (bottom & back)
- Material: 13 gauge (2.3)
- Standard finish: ZN
- Wt./C 13 Lbs. (3.9 kg)

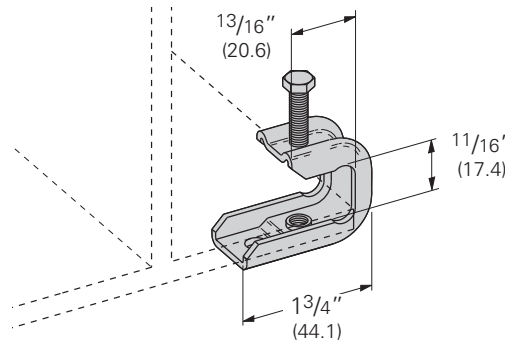

B210 Beam Clamp

- Design Load 800 Lbs. (3.56 kN)
- Safety Factor of 5
- 5/8" (15.9) Max. flange thickness
- 1/2"-13 Setscrew included
- Standard finish: ZN
- Wt./C 100 Lbs. (45.3 kg)

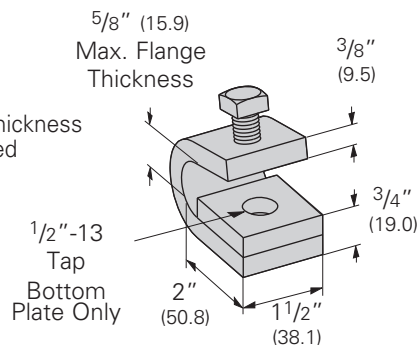

B210A Beam Clamp

- Design Load 300 Lbs. (1.33 kN)
- Safety Factor of 5
- 3/4" (19.0) Max. flange thickness
- 3/8"-16 Setscrew included
- Standard finish: ZN
- Wt./C 60 Lbs. (27.2 kg)

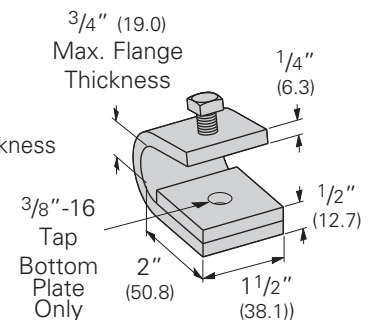

Reference page 154 for general fitting and standard finish specifications.

B303 thru B309 Beam Clamps

- Safety Factor of 5
- Max. flange thickness $1/16''$ (1.6) thru $7/8''$ (22.2)
- Setscrew included
- When retaining strap is required, order B312 separately
- Recommended setscrew torque: $3/8''$ -16 150 in-lbs. (16.9 N•m)
 $1/2''$ -13 350 in-lbs. (39.5 N•m)
- Standard finishes: ZN, HDG

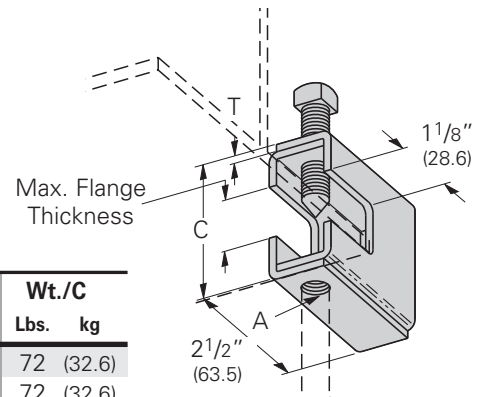

Part No.	Thread Size A	Set Screw	C		D		Design Load		Wt./C	
			In.	mm	In.	mm	Lbs.	kN	Lbs.	kg
B303	1/4"-20	3/8"-16	2 ⁵ / ₁₆ "	(58.7)	11 Ga.	(3.0)	400	(1.78)	72	(32.6)
B304	5/16"-18	3/8"-16	2 ⁵ / ₁₆ "	(58.7)	11 Ga.	(3.0)	600	(2.67)	72	(32.6)
B305	3/8"-16	3/8"-16	2 ⁵ / ₁₆ "	(58.7)	11 Ga.	(3.0)	600	(2.67)	72	(32.6)
B306	3/8"-16	1/2"-13	2 ⁷ / ₁₆ "	(61.9)	7 Ga.	(4.5)	1100	(4.89)	97	(44.0)
B307	1/2"-13	1/2"-13	2 ⁷ / ₁₆ "	(61.9)	7 Ga.	(4.5)	1100	(4.89)	97	(44.0)
B308	1/2"-13	1/2"-13	2 ⁹ / ₁₆ "	(65.1)	1/4"	(6.3)	1500	(6.67)	133	(60.3)
B309	5/8"-11	1/2"-13	2 ⁹ / ₁₆ "	(65.1)	1/4"	(6.3)	1500	(6.67)	133	(60.3)

B321 Series Beam Clamps

- Safety Factor of 5
- $1\frac{1}{16}''$ (42.8) Max. Flange Thickness
- Setscrew included
- When retaining strap is required, order B312 separately
- Recommended setscrew torque: $1/2''$ -13 350 in-lbs. (39.5 N•m)
 $5/8''$ -11 700 in-lbs. (79.0 N•m)
- Minimum flange thickness: B321-1 thru B321-3 $1/4''$ (6.3)
B321-4 and B321-5 $3/8''$ (9.5)
- Standard finishes: ZN, HDG

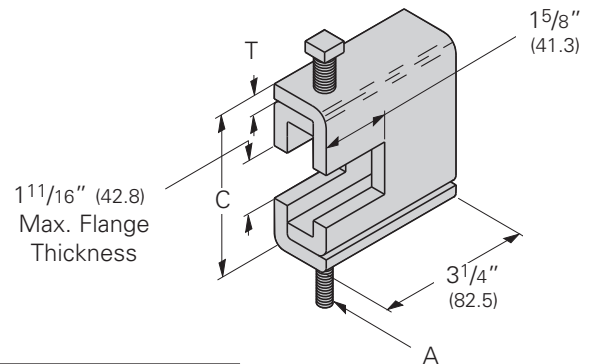

Part No.	Thread Size A	Setscrew Size	C		D		Design Load		Wt./C	
			In.	mm	In.	mm	Lbs.	kN	Lbs.	kg
B321-1	3/8"-16	1/2"-13	3 ⁹ / ₁₆ "	(92.1)	1/4"	(6.3)	1300	(5.78)	187	(84.8)
B321-2	1/2"-13	1/2"-13	3 ⁹ / ₁₆ "	(92.1)	1/4"	(6.3)	1400	(6.23)	186	(84.3)
B321-3	5/8"-11	1/2"-13	3 ⁹ / ₁₆ "	(92.1)	1/4"	(6.3)	1600	(7.12)	185	(83.9)
B321-4	5/8"-11	5/8"-11	3 ²³ / ₃₂ "	(94.4)	5/16"	(7.9)	1800	(8.00)	239	(108.4)
B321-5	3/4"-10	5/8"-11	3 ²³ / ₃₂ "	(94.4)	5/16"	(7.9)	2000	(8.89)	238	(107.9)

B312 Series Retaining Strap for use with B303 thru B309 and B321 Series

- $3/4''$ (19.0) Max. flange thickness
- For thicker beams, step up one flange width size
- Material: 14 gauge (1.9)
- Standard finishes: GALV, HDG

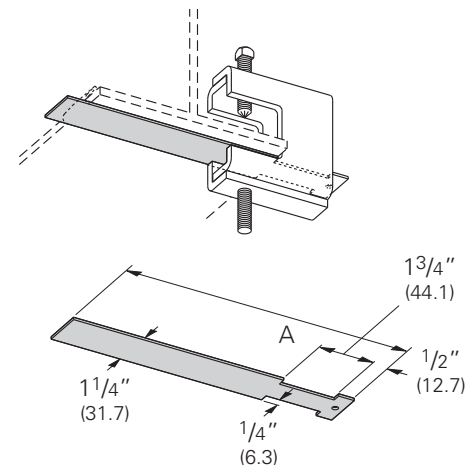

Part No.	For Flange Width		A		Wt./C	
	In.	mm	In.	mm	Lbs.	kg
B312-6	6"	(152.4)	9"	(228.6)	22	(10.0)
B312-9	9"	(228.6)	12"	(304.8)	30	(13.6)
B312-12	12"	(304.8)	15"	(381.0)	40	(18.1)
B312-15	15"	(381.0)	18"	(457.2)	49	(22.2)

Reference page 154 for general fitting and standard finish specifications.

Beam Clamps

B751 Beam Clamp

- Safety Factor of 5
- 3/4" (19.0) Max. flange thickness
- Setscrew and locknut included
- Maximum ATR size 1/2"
- Use B753 Swivel nut (not included)
- Material: 12 gauge (2.6)
- Standard finish: ZN, HDG
- Wt./C 42 Lbs. (19.0 kg)

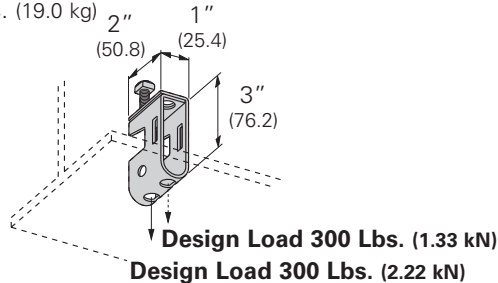

B752 Beam Clamp Swivel

- Design Load 500 Lbs. (2.22 kN)
- Safety Factor of 5
- Material: 12 gauge (2.6)
- Use B753 Swivel nut (not included)
- Includes:
 - 1 pc. B752 Swivel body
 - 1 pc. 5/16"-18 x 1 3/4" HHCS
 - 1 pc. 5/16"-18 Hex nut
- Standard finish: ZN
- Wt./C 30 Lbs. (13.6 kg)

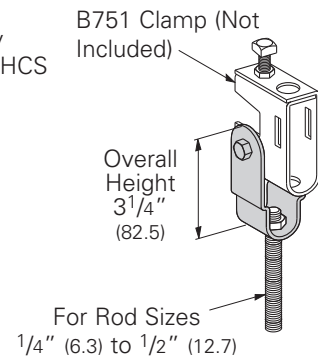

B751-J_3/8 Beam Clamp Assembly

- Includes:
 - 1 pc. B751 Beam clamp
 - 1 pc. B701 Type J-Hook only
 - 1 pc. SA203-158 Clip
 - 1 pc. 3/8"-16 Hex Nut
- 1/4" (6.3) Diameter J-Hook available upon request
Part Number changes to B751-J_1/4 and a 1/4-20 machine square nut (MSQN) is used
- Use B753 Swivel Nut (not included)
- Standard finishes: ZN

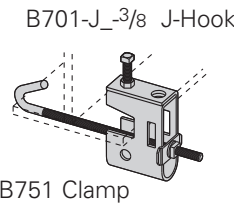

Part No.	For Flange Width		Wt./C	
	In.	mm	Lbs.	kg
B751-J4-3/8	3"-6"	(76.2-152.4)	70	(31.7)
B751-J6-3/8	5"-9"	(127.0-228.6)	78	(35.4)
B751-J9-3/8	8"-12"	(203.2-304.8)	83	(37.6)
B751-J12-3/8	11"-15"	(279.4-381.0)	88	(39.9)

B753 Swivel Nut

- Provides a full swivel of 15° in any direction
Specify rod size
- Standard finish: ZN

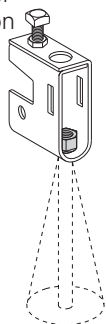

Part No.	For Rod Size	Wt./C	
		Lbs.	kg
B753-3/8	3/8"-16	4.0	(1.8)
B753-1/2	1/2"-13	3.4	(1.5)

B701 Series J-Hook

- 1/4" (6.3) Diameter J-Hook available upon request
Part Number changes to B751-J_1/4 and a 1/4-20 machine square nut (MSQN) is used
- Standard finish: ZN

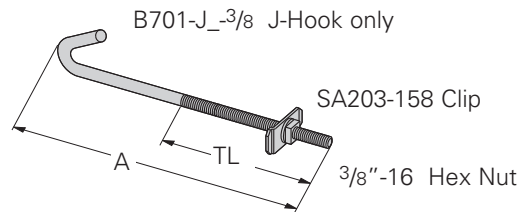

Part No.	A		Thread Length TL		Wt./C	
	In.	mm	In.	mm	Lbs.	kg
B701-J4-3/8	8 3/4"	(222.2)	5 1/2"	(139.7)	26	(11.8)
B701-J6-3/8	11 3/4"	(298.4)	6 1/2"	(165.1)	34	(15.4)
B701-J9-3/8	14 3/4"	(374.6)	6 1/2"	(165.1)	41	(18.6)
B701-J12-3/8	17 3/4"	(450.8)	6 1/2"	(165.1)	48	(21.8)

Reference page 154 for general fitting and standard finish specifications.

B755 3/8" Beam Clamp

- Safety Factor of 5
- 5/8" (15.9) Max. flange thickness
- For 3/8"-16 Hanger rod only
- Material: 12 gauge (2.6)
- Includes:

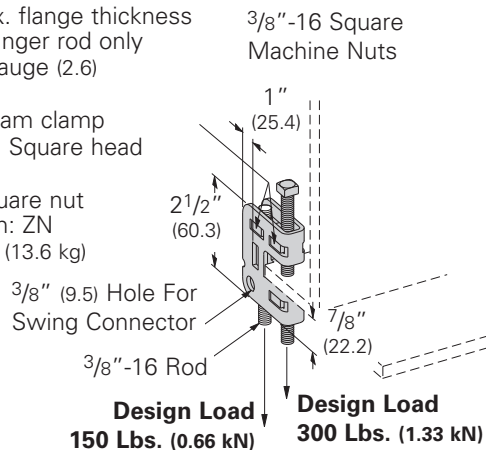

B756-3/8 Swing Connector

- Design Load 150 Lbs. (0.66 kN)
- Safety Factor of 5
- Material: 12 gauge (2.6)
- Includes:

B755 Clamp
(Not Included)

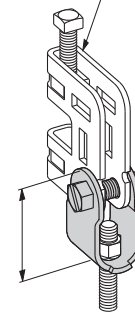

Overall Height
1 7/8"
(47.6)

B755-3/8 -J_ Beam Clamp Assembly

- Includes:

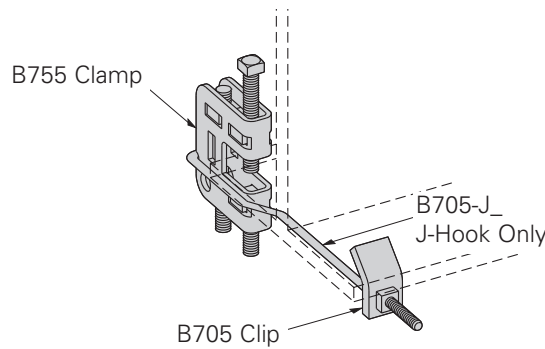

Part No.	For Flange Width		Wt./C	
	In.	mm	Lbs.	kg
B755-3/8-J4	4"-6"	(101.6-152.4)	47	(21.3)
B755-3/8-J6	6"-10"	(152.4-254.0)	51	(23.1)
B755-3/8-J10	10"-12"	(254.0-304.8)	53	(24.0)
B755-3/8-J12	12"-14"	(304.8-355.6)	55	(24.9)

B705 Series J-Hook

- Use with B755-3/8
- Standard finish: ZN

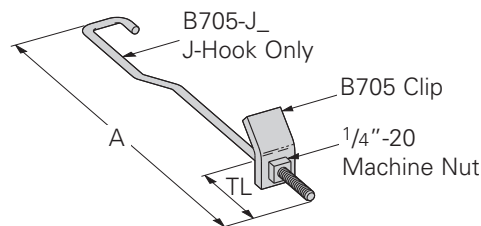

Part No.	A		Thread Length TL		Wt./C	
	In.	mm	In.	mm	Lbs.	kg
B705-J4	7 3/8"	(187.3)	3"	(76.2)	17	(7.7)
B705-J6	11 3/8"	(288.9)	4 1/2"	(114.3)	21	(9.5)
B705-J10	13 3/8"	(339.7)	4 1/2"	(114.3)	23	(10.4)
B705-J12	15 3/8"	(390.5)	4 1/2"	(114.3)	25	(11.3)

Reference page 154 for general fitting and standard finish specifications.

Beam Clamps

B750 Series Beam Clamp

- Safety Factor of 5
- Design Load 500 Lbs. (2.22 kN)
- Recommended Torque: J-Hook nut 125 in-lbs. (14.1 N•m)
- Maximum flange thickness $\frac{5}{8}$ " (15.9)
- Standard finish: ZN

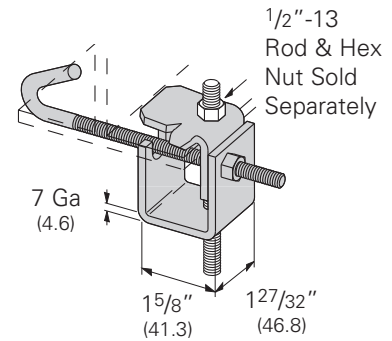

Part No.	For Flange Width		Wt./C	
	In.	mm	Lbs.	kg
B750-J4	3"-6"	(76.2-152.4)	109	(49.4)
B750-J6	5"-9"	(127.0-228.6)	124	(56.2)
B750-J9	8"-12"	(203.2-304.8)	135	(61.2)
B750-J12	11"-15"	(279.4-381.0)	147	(66.7)

B700 Series J-Hook

- Includes:
 - 1 pc. J-Bolt
 - 1 pc. Hex Nut
- Maximum flange thickness $\frac{5}{8}$ " (15.9)
- Standard finish: ZN

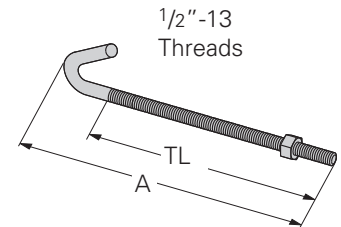

Part No.	A		Thread Length TL		Wt./C	
	In.	mm	In.	mm	Lbs.	kg
B700-J4	8 $\frac{1}{2}$ "	(215.9)	6 $\frac{3}{4}$ "	(171.4)	44	(19.9)
B700-J6	11 $\frac{1}{2}$ "	(292.1)	9 $\frac{3}{4}$ "	(247.6)	53	(24.0)
B700-J9	14 $\frac{1}{2}$ "	(368.3)	12 $\frac{3}{4}$ "	(323.8)	63	(28.6)
B700-J12	17 $\frac{1}{2}$ "	(444.5)	15 $\frac{3}{4}$ "	(400.0)	78	(35.4)

B500 Series Square U-Bolt

- Includes:
 - 1 pc. U-Bolt only
 - 2 pcs. $\frac{3}{8}$ "-16 Hex nuts
- Additional sizes available
- Standard finish: ZN, SS4

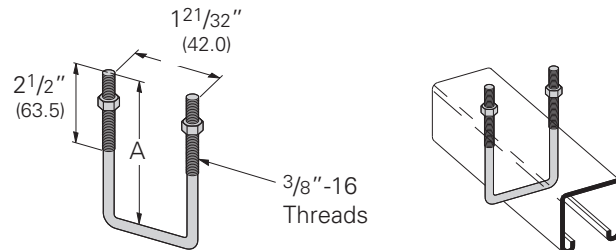

Part No.	In.		Channel Size		Wt./C	
	In.	mm	In.	mm	Lbs.	kg
B500-3-3/8	3 $\frac{3}{8}$ "	(85.7)	1 $\frac{5}{8}$ " x 1 $\frac{5}{8}$ "	(41.3 x 41.3)	25	(11.3)
B500-5	5"	(127.0)	3 $\frac{1}{4}$ " x 1 $\frac{5}{8}$ "	(82.5 x 41.3)	33	(14.9)

Reference page 154 for general fitting and standard finish specifications.

B441-22 Beam Clamp

- Design Load 1850 Lbs. (8.23 kN) when used in pairs
- Safety Factor of 5
- $\frac{3}{4}$ " (19.0) Max. flange thickness
- For use with $\frac{13}{16}$ " (20.6) to $1\frac{5}{8}$ " (41.3) high channel
- Recommended Torque: 150 in-lbs. (16.9 N•m)
- Sold in pieces
- Other flange thickness variations are available, contact us for sizes
- Standard finishes: ZN, HDG, SS4
- Wt./C 87 Lbs. (39.4 kg)

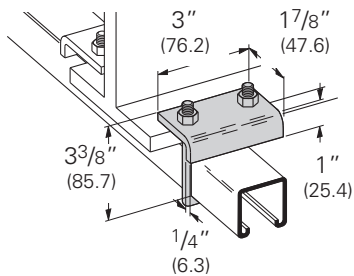

B441-22A Beam Clamp

- Design Load 1850 Lbs. (8.23 kN) when used in pairs
- Safety Factor of 5
- $\frac{3}{4}$ " (19.0) Max. flange thickness
- For use with $1\frac{5}{8}$ " (41.3) to $3\frac{1}{4}$ " (82.5) high channel
- Recommended Torque: 150 in-lbs. (16.9 N•m)
- Sold in pieces
- Other flange thickness variations are available, contact us for sizes
- Standard finishes: ZN, HDG, SS4
- Wt./C 93 Lbs. (42.2 kg)

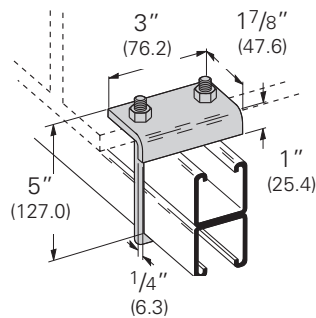

B314 Beam Clamp

- Design Load 900 Lbs. (4.00 kN) when used in pairs
- Safety Factor of 5
- $\frac{5}{8}$ " (15.9) Max. flange thickness
- For use with channel $1\frac{5}{8}$ " (41.3) in height
- Setscrew included
- Sold in pieces
- Standard finishes: ZN, GRN, HDG, SS4
- Wt./C 105 Lbs. (47.6 kg)

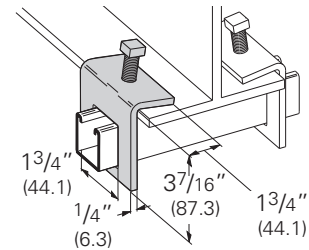

B441Z-22 Beam Clamp

- Design Load 1200 Lbs. (5.34 kN) when used in series
- Safety Factor of 5
- Sold in pieces
- For use with $\frac{13}{16}$ " (20.6) to $1\frac{5}{8}$ " (41.3) high channel
- Recommended Torque: 150 in-lbs. (16.9 N•m)
- Standard finishes: ZN
- Wt./C 95 Lbs. (43.1 kg)

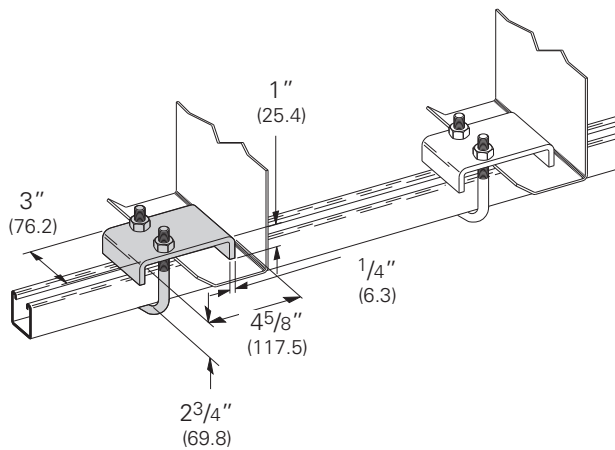

B441Z-22A Beam Clamp

- Design Load 1200 Lbs. (5.34 kN) when used in series
- Safety Factor of 5
- Sold in pieces
- For use with $1\frac{5}{8}$ " (41.3) to $3\frac{1}{4}$ " (82.5) high channel
- Recommended Torque: 150 in-lbs. (16.9 N•m)
- Standard finishes: ZN
- Wt./C 101 Lbs. (45.8 kg)

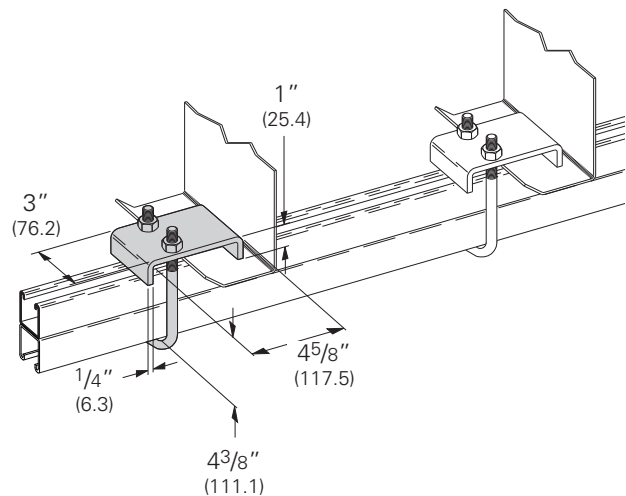

Reference page 154 for general fitting and standard finish specifications.

Beam Clamps

B211 Zee Beam Clamp

- Design Load 600 Lbs. (2.67 kN) when used in pairs
- Safety Factor of 5
- 1" (25.4) Max. flange thickness
- 1/2"-13 Setscrew included
- Sold in pieces
- Order 1/2"-13 HHCS and channel nut separately
- Standard finishes: ZN, HDG
- Wt./C 66 Lbs. (29.9 kg)

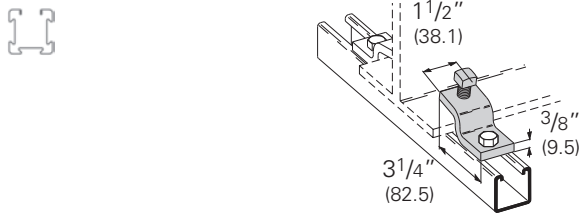

B213 I-Beam Clamp

- Design Load 900 Lbs. (4.00 kN) when used in pairs
- Safety Factor of 5
- 7/8" (22.2) Max. flange thickness
- 1/2"-13 Setscrew included
- Sold in pieces
- Order 1/2"-13 x 2 1/4" HHCS and channel nut separately
- Material: Malleable iron
- Standard finishes: ZN, GRN
- Wt./C 95 Lbs. (43.1 kg)

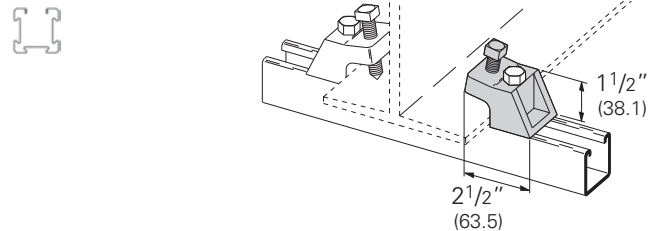

B355 Beam Clamp

- Design Load 1200 Lbs. (5.34 kN) when used in pairs
- Safety Factor of 5
- 5/8" (15.9) Max. flange thickness
- Sold in pieces
- Order 1/2"-13 x 1 1/2" HHCS and channel nut separately
- Standard finishes: ZN, GRN, HDG, SS4
- Wt./C 30 Lbs. (13.6 kg)

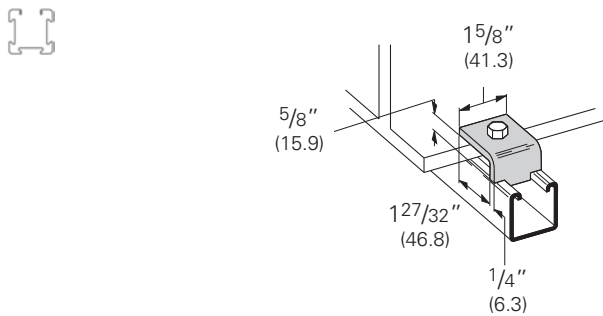

B212-1/4 I-Beam Clamp

- Design Load 600 Lbs. (2.67 kN) when used in pairs
- Safety Factor of 5
- 7/8" (22.2) Max. flange thickness
- 3/8"-16 Setscrew included
- Sold in pieces
- Standard finish: ZN
- Wt./C 41 Lbs. (18.6 kg)

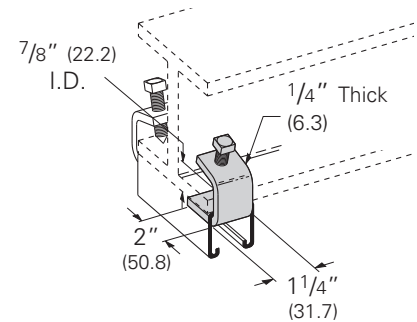

B212-3/8 I-Beam Clamp

- Design Load 1000 Lbs. (4.45 kN) when used in pairs
- Safety Factor of 5
- 1 1/8" (28.6) Max. flange thickness
- 1/2"-13 Setscrew included
- Sold in pieces
- Standard finishes: ZN, HDG
- Wt./C 62 Lbs. (28.1 kg)

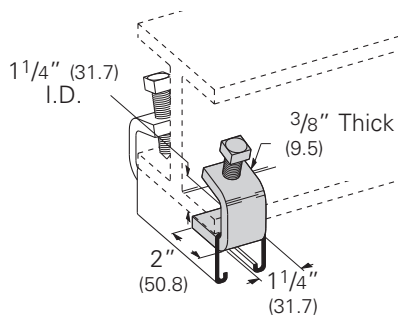

B435 Beam Clamp

- Design Load 900 Lbs. (4.00 kN) when used in pairs
- Safety Factor of 5
- 2 1/8" (54.0) Max. flange thickness
- 1/2"-13 x 2" Setscrew included
- Sold in pieces
- Standard finish: ZN
- Wt./C 82 Lbs. (37.2 kg)

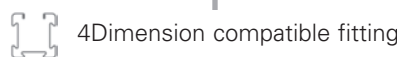
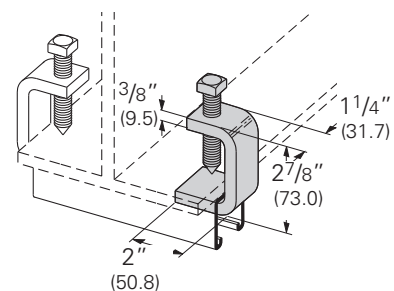

Reference page 154 for general fitting and standard finish specifications.

B427 Beam Clamp

- Design Load 1100 Lbs. (4.89 kN) when used in pairs
- Safety Factor of 5
- 2 1/2" (63.5) Max. flange thickness without channel
- 1/2"-13 x 1 1/2" Setscrew included
- Sold in pieces
- Standard finish: ZN
- Wt./C 92 Lbs. (41.7 kg)

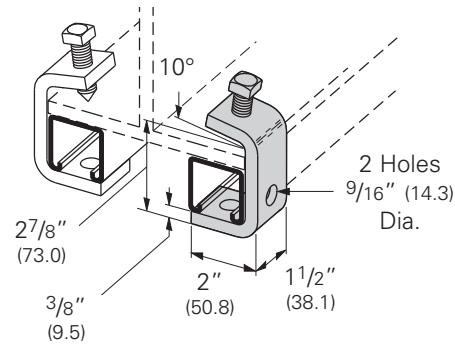

B405 Suspension Member

- Standard finishes: ZN, GRN
- Wt./C 75 Lbs. (34.0 kg)

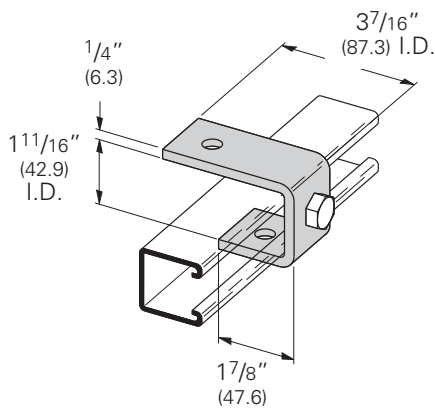

B405A Suspension Member with Beam Clamp

- 7/8" (22.2) Max. flange thickness
- Includes:
 - 1 pc. B405 Suspension member
 - 1 pc. B213 I-Beam clamp
 - 1 pc. 1/2"-13 x 2 1/2" HHCS
 - 1 pc. 1/2"-13 Hex Nut
- Material: Malleable iron
- Standard finishes: ZN, GRN
- Wt./C 183 Lbs. (83.0 kg)

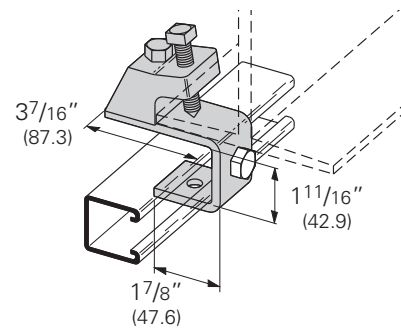

B602A THRU B602C Beam Clamp with Gusset Assembly

- Safety Factor of 5
- 7/8" (22.2) Max. flange thickness
- Includes:
 - 1 pc. B451 Slotted three hole 'U' support with gusset
 - 2 pcs. B213 I-Beam clamp
 - 2 pcs. 1/2"-13 x 2 1/2" HHCS
 - 2 pcs. 1/2"-13 Hex nuts
- Material: Malleable iron
- Standard finishes: ZN, GRN

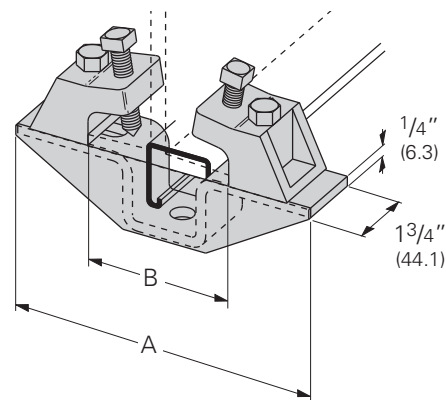

Part No.	A		For Flange Width B		Design Load		Wt./C	
	In.	mm	In.	mm	Lbs.	kN	Lbs.	kg
B602A	7 1/4"	(184.1)	2 3/8"-4 1/2"	(60.3-114.3)	1200	(5.34)	365	(165.1)
B602B	8 1/2"	(215.9)	3 3/4"-5 3/4"	(95.2-146.0)	1200	(5.34)	383	(173.7)
B602C	10 3/8"	(263.5)	5 5/8"-7 5/8"	(142.9-193.7)	1200	(5.34)	408	(185.0)

Reference page 154 for general fitting and standard finish specifications.

Beam Clamps

B760-22 Series Beam Clamp

- 1" (25.4) Max. flange thickness
- For use with 1³/₁₆" (20.6) to 1⁵/₈" (41.3) high channel
- Recommended Torques:
U-Bolt nuts 150 in-lbs. (16.9 N•m)
J-Hook nut 60 in-lbs. (6.8 N•m)
- Includes:
1 pc. B760 Plate
1 pc. B701 Type J-Hook only
1 pc. B500-3³/₈" U-Bolt only
3 pcs. ³/₈"-16 Hex nuts
- Standard finish: ZN

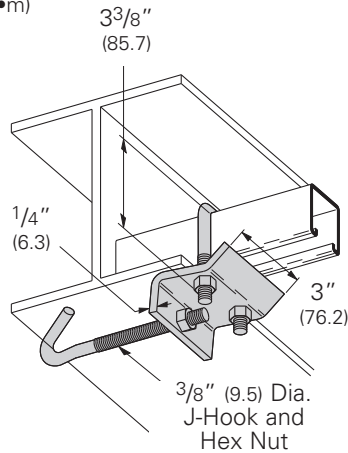

Part No.	For Flange Width		Wt./C	
	In.	mm	Lbs.	kg
B760-22-J4	4"-5 ⁷ / ₈ "	(101.6-149.2)	122	(55.3)
B760-22-J6	6"-8 ⁷ / ₈ "	(152.4-225.4)	129	(58.5)
B760-22-J9	9"-11 ⁷ / ₈ "	(228.6-301.6)	135	(61.2)
B760-22-J12	12"-14 ⁷ / ₈ "	(304.8-377.8)	141	(63.9)

B761-22 Series Beam Clamp

- 1" (25.4) Max. flange thickness
- For use with 1³/₁₆" (20.6) to 1⁵/₈" (41.3) high channel
- Recommended Torques:
U-Bolt nuts 150 in-lbs. (16.9 N•m)
ATR nuts 60 in-lbs. (6.8 N•m)
- Includes:
2 pcs. B700 Plates
2 pcs. B500-3³/₈" U-Bolts only
1 pc. ³/₈"-16 ATR (Length)
6 pcs. ³/₈"-16 Hex nuts
- Standard finish: ZN

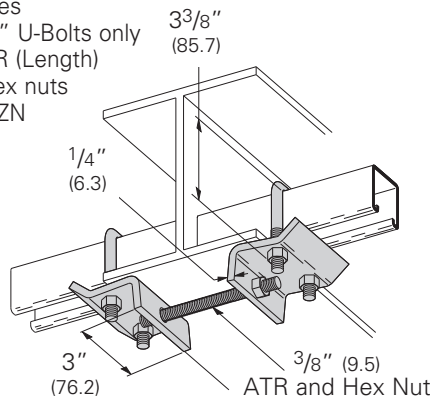

Part No.	For Flange Width		ATR Length		Wt./C	
	In.	mm	In.	mm	Lbs.	kg
B761-22-4	4"-5 ⁷ / ₈ "	(101.6-149.2)	4"	(101.6)	202	(91.6)
B761-22-6	6"-8 ⁷ / ₈ "	(152.4-225.4)	6"	(152.4)	206	(93.4)
B761-22-9	9"-11 ⁷ / ₈ "	(228.6-301.6)	9"	(228.6)	214	(97.0)
B761-22-12	12"-14 ⁷ / ₈ "	(304.8-377.8)	12"	(304.8)	221	(100.2)

B760-22A Series Beam Clamp

- 1" (25.4) Max. flange thickness
- For use with 1⁵/₈" (41.3) to 3¹/₄" (82.5) high channel
- Recommended Torques:
U-Bolt nuts 150 in-lbs. (16.9 N•m)
J-Hook nut 60 in-lbs. (6.8 N•m)
- Includes:
1 pc. B760 Plate
1 pc. B701 Type J-Hook only
1 pc. B500-5" U-Bolt only
3 pcs. ³/₈"-16 Hex nuts
- Standard finish: ZN

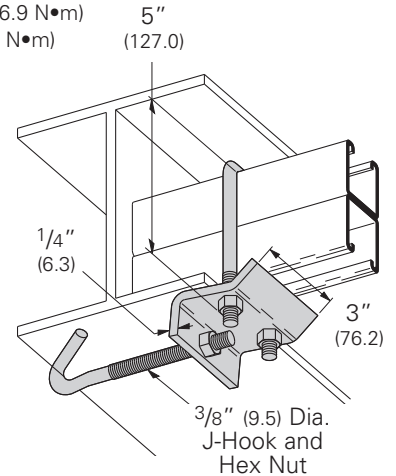

Part No.	For Flange Width		Wt./C	
	In.	mm	Lbs.	kg
B760-22A-J4	4"-5 ⁷ / ₈ "	(101.6-149.2)	129	(58.5)
B760-22A-J6	6"-8 ⁷ / ₈ "	(152.4-225.4)	136	(61.7)
B760-22A-J9	9"-11 ⁷ / ₈ "	(228.6-301.6)	142	(64.4)
B760-22A-J12	12"-14 ⁷ / ₈ "	(304.8-377.8)	148	(67.1)

B761-22A Series Beam Clamp

- 1" (25.4) Max. flange thickness
- For use with 1⁵/₈" (41.3) to 3¹/₄" (82.5) high channel
- Recommended Torques:
U-Bolt nuts 150 in-lbs. (16.9 N•m)
ATR nuts 60 in-lbs. (6.8 N•m)
- Includes:
2 pcs. B700 Plates
2 pcs. B500-5" U-Bolts only
1 pc. ³/₈"-16 ATR (Length)
6 pcs. ³/₈"-16 Hex nuts
- Standard finish: ZN

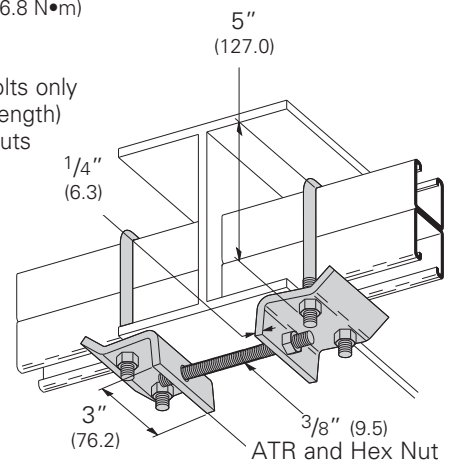

Part No.	For Flange Width		ATR Length		Wt./C	
	In.	mm	In.	mm	Lbs.	kg
B761-22A-4	4"-5 ⁷ / ₈ "	(101.6-149.2)	4"	(101.6)	216	(98.0)
B761-22A-6	6"-8 ⁷ / ₈ "	(152.4-225.4)	6"	(152.4)	220	(99.8)
B761-22A-9	9"-11 ⁷ / ₈ "	(228.6-301.6)	9"	(228.6)	228	(103.4)
B761-22A-12	12"-14 ⁷ / ₈ "	(304.8-377.8)	12"	(304.8)	235	(106.6)

Reference page 154 for general fitting and standard finish specifications.

B614 Column Support for B22

- Quick installation (one bolt to tighten)
- Design Load 800 Lbs. (3.56 kN) slip with Safety Factor of 3
- Use with B22 and B24 channel
- Sold in pairs
- Standard finish: ZN
- Wt./C 50 Lbs. (22.6 kg)

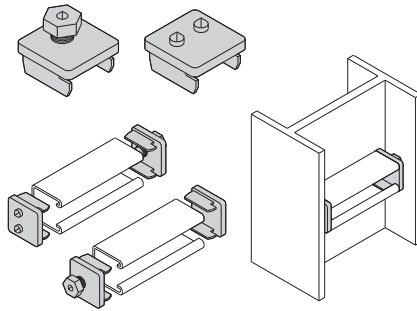

B613 Column Support for B22

- Design Load 800 Lbs. (3.56 kN) slip with Safety Factor of 3
- Use with B22 and B24 channel
- Setscrews to be torqued to 19 ft./Lbs
- Sold in pairs
- Standard finishes: ZN, GRN, HDG
- Wt./C 100 Lbs. (45.3 kg)

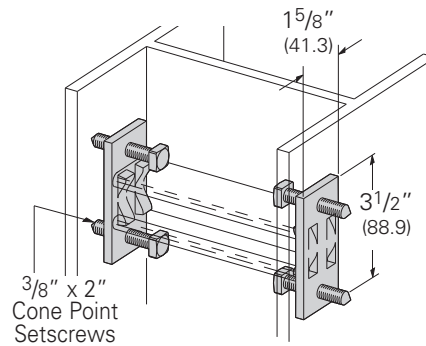

B613A Column Support for B52

- Design Load 800 Lbs. (3.56 kN) slip with Safety Factor of 3
- Use with B52 and B54 channel
- Setscrews to be torqued to 19 ft./Lbs
- Sold in pairs
- Standard finishes: ZN, GRN, HDG
- Wt./C 100 Lbs. (45.3 kg)

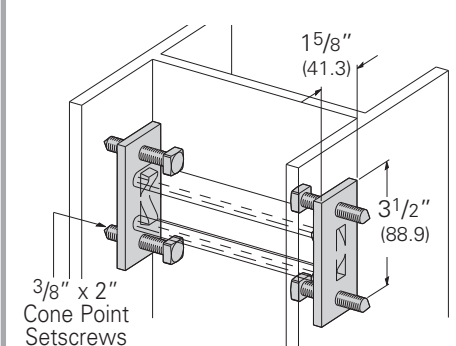

B422 Series Right Angle Clamp

- Safety Factor of 5
- Material: 7 gauge (4.5)
- Standard finishes: ZN, SS4

Part No.	Conduit Size		A		Design Load Vertical Pull		Wt./C	
	In.	mm	In.	mm	Lbs.	kN	Lbs.	kg
B422-1/2	1/2"	(15)	2 3/8"	(60.3)	250	(1.11)	38	(17.2)
B422-3/4	3/4"	(20)	2 3/8"	(60.3)	300	(1.33)	39	(17.7)
B422-1	1"	(25)	2 7/8"	(73.0)	400	(1.78)	48	(21.8)
B422-1 1/4	1 1/4"	(32)	2 7/8"	(73.0)	400	(1.78)	50	(22.7)
B422-1 1/2	1 1/2"	(40)	3 1/4"	(82.5)	500	(2.22)	59	(26.7)
B422-2	2"	(50)	3 11/16"	(93.7)	600	(2.67)	75	(34.0)
B422-2 1/2	2 1/2"	(65)	4 1/4"	(107.9)	700	(3.11)	98	(44.4)
B422-3	3"	(80)	4 7/8"	(123.8)	800	(3.56)	111	(50.3)
B422-3 1/2	3 1/2"	(90)	5 7/16"	(138.1)	900	(4.00)	123	(55.8)
B422-4	4"	(100)	6"	(152.4)	1000	(4.45)	135	(61.2)

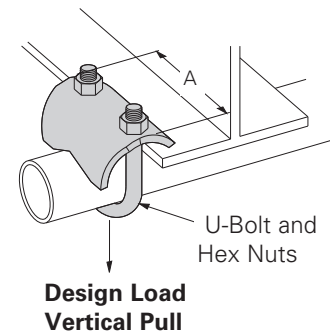

B107S U-Support

- Material: 7 gauge (4.5)
- Standard finishes: ZN, GRN
- Wt./C 51 Lbs. (23.1 kg)

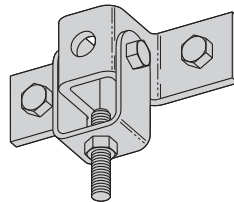
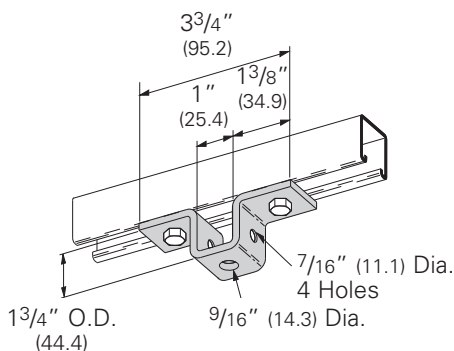

- Illustration shows B107S and B593 used together
- Design Load 900 Lbs., strength of assembly only
- Verify anchorage

B593 Clevis Swivel

- Includes:
 - 1 pc. 3/8"-16 x 2" HHCS
 - 1 pc. 3/8"-16 Hex Nut
- Material: 11 gauge (3.0)
- Standard finishes: ZN, GRN
- Wt./C 31 Lbs. (14.0 kg)

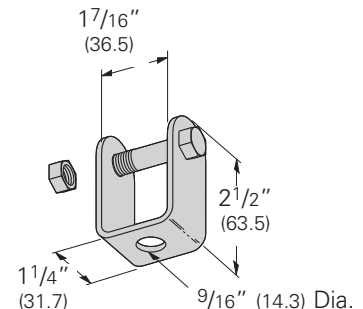

Reference page 154 for general fitting and standard finish specifications.

Pipe/Conduit Clamps & Hangers



Our beam attachments and pipe supports offered in this section are designed to provide supports without drilling or welding. A complete selection of beam clamps, pipe clamps, rollers, supports and accessories are designed for use with our channels and offer many installation advantages.

Materials & Finishes*

Pipe clamps, pipe hangers, beam clamps, brackets, and rollers are made from low carbon steel strips, plates or rod unless noted.

*Unless otherwise noted.

Load Data

The load data published includes a safety factor of 5.0 unless noted (safety factor = ratio of ultimate load to the design load).

Recommended Bolt Torque (unless noted)

*See chart on page 154 for recommended setscrew torquing.

Finish Code	Finish	Specification
PLN	Plain	ASTM A1011 33,000 PSI min. yield
ZN	Electro-Plated Zinc	ASTM B633 SC3 Type III or ASTM A653
GRN	DURA GREEN™	
DCU	DURA-COPPER™	
HDG	Hot-Dipped Galvanized	ASTM A123
YZN	Yellow Zinc Chromate	ASTM B633 SC3 Type II
SS4	Stainless Steel Type 304	ASTM A240
SS6	Stainless Steel Type 316	ASTM A240
AL	Aluminum	ASTM B209

Bolt Size	1/4"-20	5/16"-18	3/8"-16	1/2"-13
ft·lbs	6	11	19	50
Nm	8	15	26	68

Metric

Metric dimensions are shown in parentheses. Unless noted, all metric dimensions are in millimeters.

B2207 thru B2213 Multi-Grip Pipe Clamps for Thinwall (EMT), I.M.C., Rigid Conduit or Pipe

- Safety Factor of 5
- Add PA to suffix for pre-assembled pipe clamps
- Includes combination recess hex head machine screw and square nut
- Material: ASTM A1011 33,000 PSI min. yield
- Standard finish: ZN



For UL installations, follow Table 9 in UL2239.

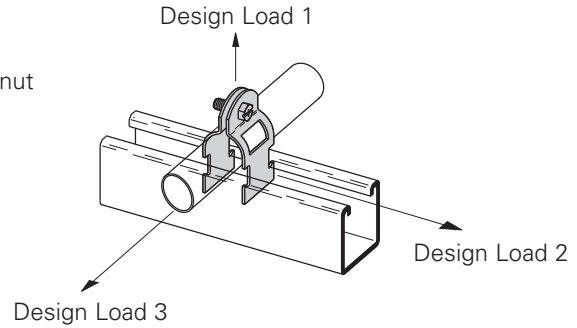

Part No.	Nominal Size In. mm	Material Thickness In. mm	O.D. Size Range		Alternate For Clamp No.'s	Design Load 1		Design Load 2		Design Load 3		Wt./C	
			In.	mm		Lbs.	kN	Lbs.	kN	Lbs.	kN	Lbs.	kg
B2207	3/8" (10)	16 Ga. (1.5)	.557-.706	(14.2-17.9)	B2000, B2001, B2026	400	(1.78)	50	(.22)	50	(.22)	9	(4.1)
B2208	1/2" (15)	16 Ga. (1.5)	.701-.875	(17.8-22.2)	B2001, B2008, B2027, B2028	400	(1.78)	50	(.22)	50	(.22)	11	(5.0)
B2209	3/4" (20)	14 Ga. (1.9)	.917-1.081	(23.2-27.4)	B2002, B2009,	400	(1.78)	50	(.22)	50	(.22)	12	(5.4)
B2210	1" (25)	14 Ga. (1.9)	1.125-1.375	(28.6-34.9)	B2003, B2010, B2030, B2031,	400	(1.78)	50	(.22)	50	(.22)	13	(5.9)
B2211	1 1/4" (32)	14 Ga. (1.9)	1.500-1.691	(38.1-42.9)	B2004, B2011, B2033, B2034	400	(1.78)	50	(.22)	50	(.22)	15	(6.8)
B2212	1 1/2" (40)	12 Ga. (2.6)	1.735-1.931	(44.0-49.0)	B2005, B2012, B2035	600	(2.67)	75	(.33)	75	(.33)	23	(10.4)
B2213	2" (50)	12 Ga. (2.6)	2.192-2.400	(55.7-60.9)	B2006, B2013 B2039	600	(2.67)	75	(.33)	75	(.33)	26	(11.8)

Pipe/Conduit Clamps & Hangers

BPC-8 thru BPC-64 Break-Apart Conduit Clamp

- Design Load 200 Lbs. (.896 kN)
- Includes combination recess hex head machine screw
- Material: ASTM A1011 33,000 PSI min. yield
- Recommended Torque 35 in. - lbs.
- Standard finish: ZN



For UL installations, follow Table 9 in UL2239.

Part No.	Rigid or EMT Conduit Size		Wt./C	
	In.	mm	Lbs.	kg
BPC-8	1/2"	(21.3)	11.2	(5.1)
BPC-12	3/4"	(26.7)	12.7	(5.8)
BPC-16	1"	(33.4)	14.5	(6.6)
BPC-20	1 1/4"	(42.2)	16.5	(7.5)
BPC-24	1 1/2"	(48.3)	18.5	(8.4)
BPC-32	2"	(60.3)	21.5	(9.8)
BPC-40	2 1/2"	(73.0)	21.5	(9.8)
BPC-48	3"	(88.9)	22.0	(10.0)
BPC-56	3 1/2"	(101.6)	23.0	(10.4)
BPC-64	4"	(114.3)	27.5	(12.5)

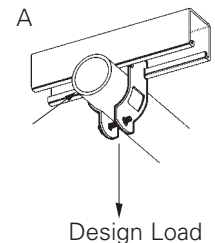
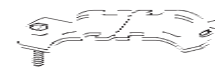

Reference page 168 for general fitting and standard finish specifications.

Pipe Clamps

BCTS Series Conduit Trapeze Support For Thinwall (EMT), Rigid Conduit or Pipe



- Used to support multiple runs of conduit/pipe on same elevation
- Available in three sizes:
 - BCTS1** series for up to 1 1/4" EMT or 1" Rigid conduit - 16 ga. (1.5mm)
 - BCTS2** series for up to 2" EMT or 2" Rigid conduit - 16 ga. (1.5mm)
 - BCTS3** series for up to 4" EMT or 4" Rigid conduit - 14 ga. (1.9mm)
- Bushings available for all three sizes
- Multiple lengths available in 6" (152mm) intervals from 12" (305mm) to 120" (3048mm)
- Can be supported with 3/8" or 1/2" threaded rod or bolts by simply flipping the part from top to bottom (threaded rod and hardware is not included)
- Reduces need for conduit/pipe clamps at every support location
- Can be tiered to support multiple conduit/pipe levels
- Can also support Flextray™ and cable tray
- Flange hole patterns provide multiple options for hanger rods, mounting hardware, or accessories
- Repeating 6" (152mm) hole pattern for field cutting
- Hanger rod spacing should not exceed 36" (914mm)
- UL Listed for US and Canada - 500 lb. (22.2kN) load rating at 12" (305mm) hanger spacing for all three sizes - safety factor of 3
- Material: Pre-Galvanized Steel, Stainless Steel Type 316 (add SS6 to part number, i.e. BCTS1-24SS6)

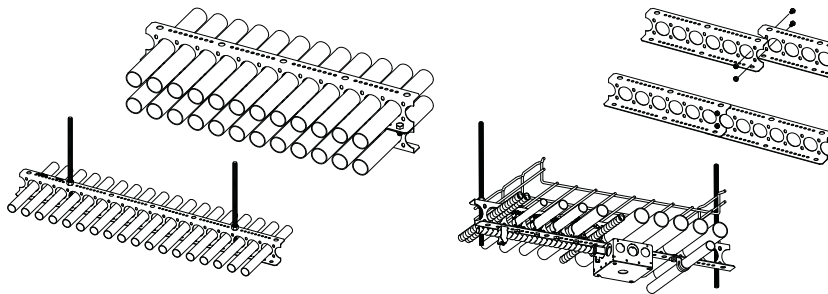
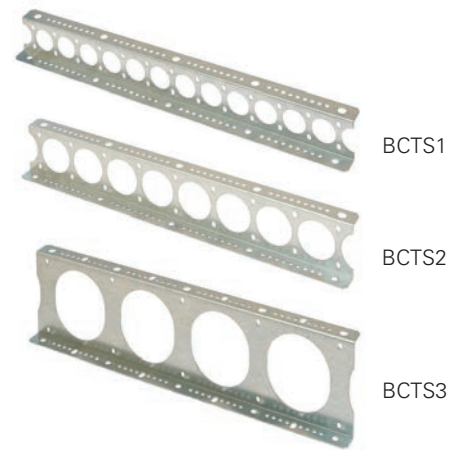

BCTS1 Series - 1 1/4" EMT/1" Rigid Maximum

Hanger rod spacing loads: Safety Factor of 3 - Evenly distributed maximum loads • 24" (609mm) is 450 lbs. (2.00kN) • 36" (914mm) is 350 lbs. (1.55kN)

Part No.	Nominal Length		Overall Length		Conduit Holes	Wt./C	
	In.	mm	In.	mm		Lbs.	kg
BCTS1-12	12	(305)	14	(355)	6	87	(39.4)
BCTS1-18	18	(457)	20	(508)	9	124	(56.2)
BCTS1-24	24	(609)	26	(660)	12	162	(73.5)
BCTS1-30	30	(762)	32	(813)	15	199	(90.2)
BCTS1-36	36	(914)	38	(965)	18	237	(107.5)
BCTS1-42	42	(1067)	44	(1117)	21	274	(124.3)
BCTS1-48	48	(1219)	50	(1270)	24	311	(141.0)
BCTS1-54	54	(1371)	56	(1422)	27	349	(158.3)
BCTS1-60	60	(1524)	62	(1575)	30	386	(175.1)
BCTS1-66	66	(1676)	68	(1727)	33	423	(191.9)
BCTS1-72	72	(1829)	74	(1879)	36	461	(209.1)
BCTS1-78	78	(1981)	80	(2032)	39	498	(225.9)
BCTS1-84	84	(2133)	86	(2184)	42	536	(243.1)
BCTS1-90	90	(2286)	92	(2337)	45	573	(259.9)
BCTS1-96	96	(2438)	98	(2489)	48	610	(276.7)
BCTS1-102	102	(2591)	104	(2641)	51	648	(293.9)
BCTS1-108	108	(2743)	110	(2794)	54	685	(310.7)
BCTS1-114	114	(2895)	116	(2946)	57	722	(327.5)
BCTS1-120	120	(3048)	122	(3099)	60	760	(344.7)
BCTB1	Bushing for 1 5/8" Holes					0.4	(0.18)

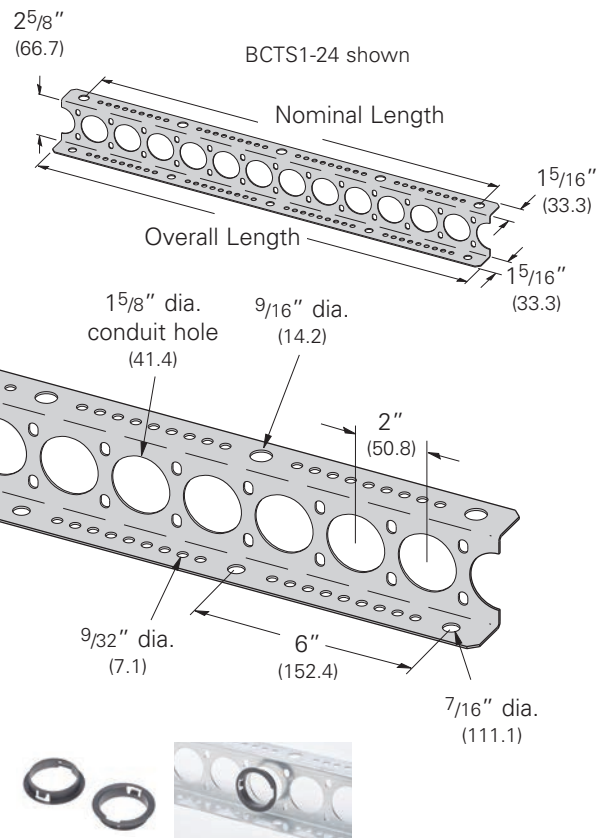

Reference page 168 for general fitting and standard finish specifications.

BCTS Series Conduit Trapeze Support For Thinwall (EMT), Rigid Conduit or Pipe (Continued)

BCTS2 Series - 2" EMT/2" Rigid Maximum

Hanger rod spacing loads: Safety Factor of 3 - Evenly distributed maximum loads • 24" (609mm) is 400 lbs. (1.78kN) • 36" (914mm) is 300 lbs. (1.33kN)

Part No.	Nominal Length		Overall Length		Conduit Holes	Wt./C	
	In.	mm	In.	mm		Lbs.	kg
BCTS2-12	12	(305)	14	(355)	4	95	(43.1)
BCTS2-18	18	(457)	20	(508)	6	135	(61.2)
BCTS2-24	24	(609)	26	(660)	8	175	(79.3)
BCTS2-30	30	(762)	32	(813)	10	215	(97.5)
BCTS2-36	36	(914)	38	(965)	12	255	(115.6)
BCTS2-42	42	(1067)	44	(1117)	14	295	(133.8)
BCTS2-48	48	(1219)	50	(1270)	16	335	(151.9)
BCTS2-54	54	(1371)	56	(1422)	18	375	(170.1)
BCTS2-60	60	(1524)	62	(1575)	20	415	(188.2)
BCTS2-66	66	(1676)	68	(1727)	22	455	(206.3)
BCTS2-72	72	(1829)	74	(1879)	24	495	(224.5)
BCTS2-78	78	(1981)	80	(2032)	26	535	(242.6)
BCTS2-84	84	(2133)	86	(2184)	28	575	(260.8)
BCTS2-90	90	(2286)	92	(2337)	30	615	(278.9)
BCTS2-96	96	(2438)	98	(2489)	32	655	(297.1)
BCTS2-102	102	(2591)	104	(2641)	34	695	(315.2)
BCTS2-108	108	(2743)	110	(2794)	36	735	(333.3)
BCTS2-114	114	(2895)	116	(2946)	38	775	(351.5)
BCTS2-120	120	(3048)	122	(3099)	40	815	(369.6)
BCTB2	Bushing for 2 ⁵ / ₈ " Holes					0.70	(0.32)

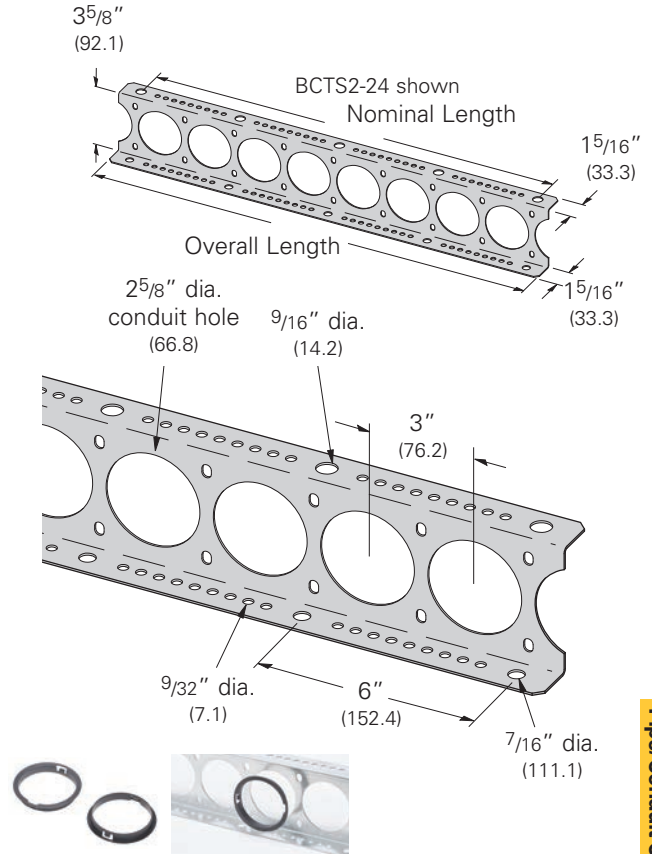

BCTS3 Series - 4" EMT/4" Rigid Maximum

Hanger rod spacing loads: Safety Factor of 3 - Evenly distributed maximum loads • 24" (609mm) is 800 lbs. (3.56kN) • 36" (914mm) is 750 lbs. (3.33kN)

Part No.	Nominal Length		Overall Length		Conduit Holes	Wt./C	
	In.	mm	In.	mm		Lbs.	kg
BCTS3-12	12	(305)	14	(355)	2	168	(76.2)
BCTS3-18	18	(457)	20	(508)	3	235	(106.6)
BCTS3-24	24	(609)	26	(660)	4	302	(137.0)
BCTS3-30	30	(762)	32	(813)	5	369	(167.3)
BCTS3-36	36	(914)	38	(965)	6	436	(197.7)
BCTS3-42	42	(1067)	44	(1117)	7	504	(228.6)
BCTS3-48	48	(1219)	50	(1270)	8	571	(259.0)
BCTS3-54	54	(1371)	56	(1422)	9	638	(289.3)
BCTS3-60	60	(1524)	62	(1575)	10	705	(319.8)
BCTS3-66	66	(1676)	68	(1727)	11	772	(350.1)
BCTS3-72	72	(1829)	74	(1879)	12	840	(381.0)
BCTS3-78	78	(1981)	80	(2032)	13	907	(411.4)
BCTS3-84	84	(2133)	86	(2184)	14	974	(441.8)
BCTS3-90	90	(2286)	92	(2337)	15	1041	(472.2)
BCTS3-96	96	(2438)	98	(2489)	16	1108	(502.5)
BCTS3-102	102	(2591)	104	(2641)	17	1175	(533.0)
BCTS3-108	108	(2743)	110	(2794)	18	1243	(563.8)
BCTS3-114	114	(2895)	116	(2946)	19	1310	(594.2)
BCTS3-120	120	(3048)	122	(3099)	20	1377	(624.6)
BCTB3	Bushing for 4 ⁵ / ₈ " x 5 ¹ / ₄ " Holes					1.3	(0.58)

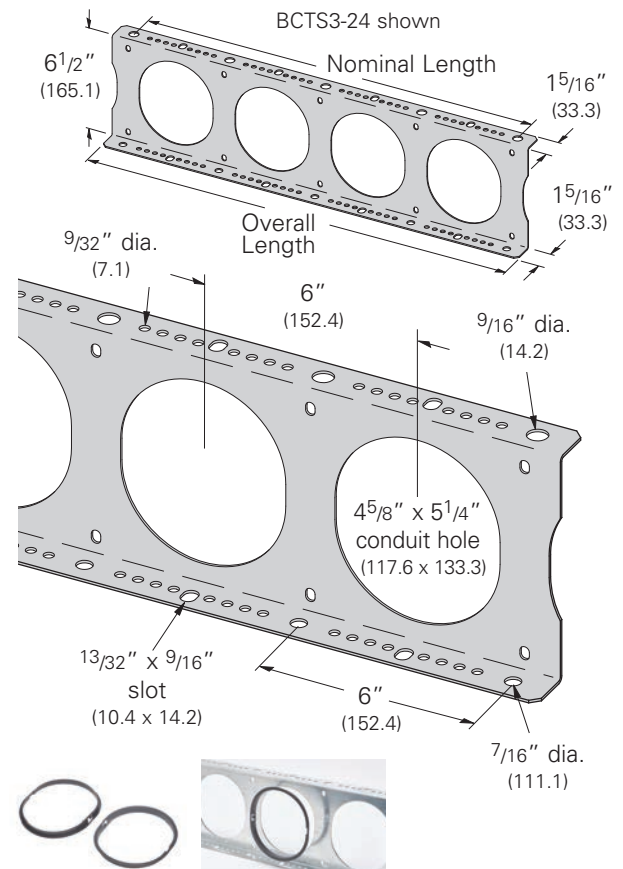

Reference page 168 for general fitting and standard finish specifications.

Pipe Clamps

B2000 Series Pipe and Conduit Clamps

- Safety Factor of 5
- Add PA to suffix for pre-assembled pipe clamps
- Includes combination recess hex head machine screw and square nut
- Material: 16 Ga. (1.5), 14 Ga. (1.9), 12 Ga. (2.6) ASTM A653 33,000 PSI min. yield and 11 Ga. (3.0) ASTM A1011HSLA Gr. 50
- Standard finishes: ZN, HDG, SS4, SS6, AL

Note: For EMT sizes 2 1/2" and larger use rigid conduit sizes.



OSO

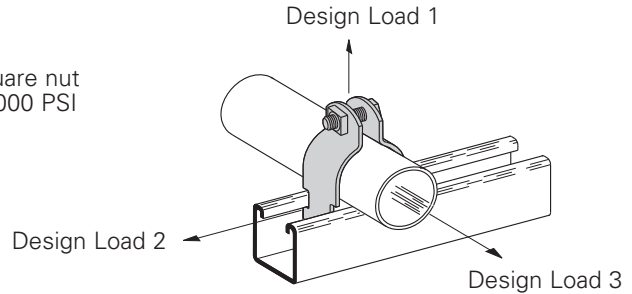

Thinwall Conduit (EMT) Clamps

Part No.	Conduit Size		Material Thickness		Design Load 1		Design Load 2		Design Load 3		Wt./C	
	In.	mm	In.	mm	Lbs.	kN	Lbs.	kN	Lbs.	kN	Lbs.	kg
B2000	3/8"	(10)	16 Ga.	(1.5)	400 U	(1.78)	50	(.22)	50	(.22)	10	(4.5)
B2001	1/2"	(15)	16 Ga.	(1.5)	400 U	(1.78)	50	(.22)	50	(.22)	10	(4.5)
B2002	3/4"	(20)	16 Ga.	(1.9)	400 U	(1.78)	50	(.22)	50	(.22)	11	(5.0)
B2003	1"	(25)	14 Ga.	(1.9)	600 U	(2.67)	75	(.33)	75	(.33)	16	(7.2)
B2004	1 1/4"	(32)	14 Ga.	(1.9)	600 U	(2.67)	75	(.33)	75	(.33)	19	(8.6)
B2005	1 1/2"	(40)	12 Ga.	(2.6)	800 U	(3.56)	125	(.56)	125	(.56)	28	(12.7)
B2006	2"	(50)	12 Ga.	(2.6)	800 U	(3.56)	125	(.56)	125	(.56)	33	(14.9)

Rigid or Conduit or Pipe Clamps

Part No.	Conduit Size		Material Thickness		Design Load 1		Design Load 2		Design Load 3		Wt./C	
	In.	mm	In.	mm	Lbs.	kN	Lbs.	kN	Lbs.	kN	Lbs.	kg
B2001	3/8"	(10)	16 Ga.	(1.5)	400 U	(1.78)	50	(.22)	50	(.22)	10	(4.5)
B2008	1/2"	(15)	16 Ga.	(1.5)	400 U	(1.78)	50	(.22)	50	(.22)	11	(5.0)
B2009	3/4"	(20)	14 Ga.	(1.9)	600 U	(2.67)	75	(.33)	75	(.33)	15	(6.8)
B2010	1"	(25)	14 Ga.	(1.9)	600 U	(2.67)	75	(.33)	75	(.33)	16	(7.2)
B2011	1 1/4"	(32)	14 Ga.	(1.9)	600 U	(2.67)	75	(.33)	75	(.33)	20	(9.1)
B2012	1 1/2"	(40)	12 Ga.	(2.6)	800 U	(3.56)	125	(.56)	125	(.56)	30	(13.6)
B2013	2"	(50)	12 Ga.	(2.6)	800 U	(3.56)	125	(.56)	125	(.56)	34	(15.4)
B2014	2 1/2"	(65)	12 Ga.	(2.6)	800 U	(3.56)	125	(.56)	125	(.56)	38	(17.2)
B2015	3"	(80)	12 Ga.	(2.6)	800 U	(3.56)	125	(.56)	125	(.56)	44	(19.9)
B2016	3 1/2"	(90)	12 Ga.	(2.6)	800 U	(3.56)	125	(.56)	125	(.56)	49	(22.2)
B2017	4"	(100)	12 Ga.	(2.6)	800 U	(3.56)	125	(.56)	125	(.56)	54	(24.5)
B2018	4 1/2"	(115)	11 Ga.	(3.0)	1000 U	(4.45)	200	(.89)	150	(.67)	70	(31.7)
B2019	5"	(125)	11 Ga.	(3.0)	1000 U	(4.45)	200	(.89)	150	(.67)	77	(34.9)
B2020	6"	(150)	11 Ga.	(3.0)	1000 U	(4.45)	200	(.89)	150	(.67)	100	(45.3)
B2021	7"	(175)	11 Ga.	(3.0)	1000	(4.45)	250	(1.11)	200	(.89)	115	(52.1)
B2022	8"	(200)	11 Ga.	(3.0)	1000	(4.45)	250	(1.11)	200	(.89)	128	(58.0)
B2130	10"	(254)	11 Ga.	(3.0)	1000	(4.45)	250	(1.11)	200	(.89)	160	(72.6)
B2132	12"	(305)	11 Ga.	(3.0)	1000	(4.45)	250	(1.11)	200	(.89)	185	(83.9)



As shown with U For UL installations, follow Table 9 in UL2239.



4Dimension compatible fitting
open side only OSO

Reference page 168 for general fitting and standard finish specifications.

B2000 Series PVC Clamps

- Safety Factor of 5
- Add PA to suffix for pre-assembled pipe clamps
- Includes combination recess hex head machine screw and square nut
- Material: 16 Ga. (1.5), 14 Ga. (1.9), 12 Ga. (2.6) ASTM A653 33,000 PSI min. yield and 11 Ga. (3.0) ASTM A1011HSLA Gr. 50
- Standard finishes: PVC

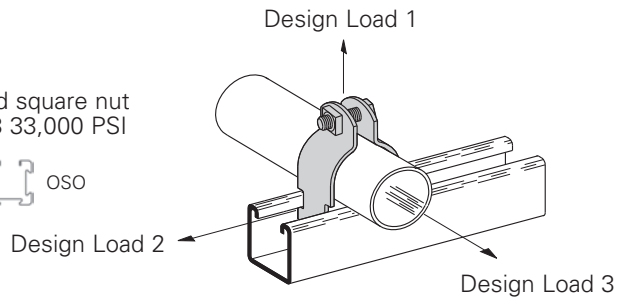

Clamp Sizing Chart for PVC Coated Rigid Conduit and Clamps

Nominal Conduit Size	Conduit Coating			
	.020 (.51mm)		.040 (1.01mm)	
	Clamp Coating		Clamp Coating	
In. mm	0	.020" (.51mm)	0	.020" (.51mm)
1/2" (15)	B2008	B2002	B2002	B2009
3/4" (20)	B2030	B2030	B2030	B2003
1" (25)	B2032	B2010	B2010	B2004
1 1/4" (32)	B2005	B2005	B2005	B2005
1 1/2" (40)	B2012	B2037	B2037	B2037
2" (50)	B2013	B2041	B2041	B2041
2 1/2" (65)	B2014	B2045	B2045	B2045
3" (80)	B2015	B2050	B2050	B2050
3 1/2" (90)	B2016	B2054	B2054	B2054
4" (100)	B2017	B2058	B2058	B2058
5" (125)	B2019	B2066	B2066	B2066
6" (150)	B2020	B2115	B2115	B2115

*See B2000 O.D. pipe and conduit clamp chart on pgs. 131-132 for corresponding clamp load data.

Clamp Sizing Chart for PVC Coated

Nominal Conduit Size	Conduit Coating			
	.020 (.51mm)		.040 (1.01mm)	
	Clamp Coating		Clamp Coating	
In. mm	0	.020" (.51mm)	0	.020" (.51mm)
3/8" (10)	B2026	B2026	B2026	B2001
1/2" (15)	B2027	B2027	B2027	B2008
3/4" (20)	B2009	B2009	B2009	B2009
1" (25)	B2003	B2031	B2031	B2031
1 1/4" (32)	B2004	B2011	B2011	B2011
1 1/2" (40)	B2005	B2005	B2005	B2012
2" (50)	B2039	B2039	B2039	B2013

*See B2000 O.D. pipe and conduit clamp chart on pgs. 131-132 for corresponding clamp load data.

B2000 Series Copper Tubing Clamps

- Safety Factor of 5
- Add PA to suffix for pre-assembled pipe clamps
- Includes combination recess hex head machine screw and square nut
- Material: 16 Ga. (1.5), 14 Ga. (1.9), 12 Ga. (2.6) ASTM A1011 33,000 PSI min. yield and 11 Ga. (3.0) ASTM A1011HSLA Gr. 50
- Standard finish: Exclusive DURA-COPPER™ Finish (DCU)

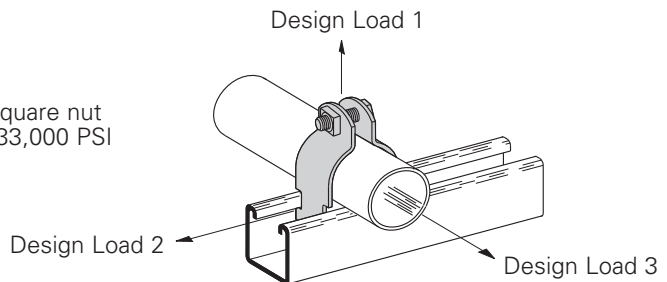

Copper Tubing Clamps

Part No.	Tubing Size	O.D. Size		Material Thickness	Design Load 1		Design Load 2		Design Load 3		Wt./C	
		In.	(mm)		Lbs.	kN	Lbs.	kN	Lbs.	kN		
B2024DCU	1/4" (6.3)	.375	(9.5)	16 Ga. (1.5)	400	(1.78)	50	(.22)	50	(.22)	8	(3.6)
B2025DCU	3/8" (9.5)	.500	(12.7)	16 Ga. (1.5)	400	(1.78)	50	(.22)	50	(.22)	9	(4.1)
B2026DCU	1/2" (12.7)	.625	(15.9)	16 Ga. (1.5)	400	(1.78)	50	(.22)	50	(.22)	10	(4.5)
B2027DCU	5/8" (15.9)	.750	(19.0)	16 Ga. (1.5)	400	(1.78)	50	(.22)	50	(.22)	10	(4.5)
B2008DCU	3/4" (19.0)	.875	(22.2)	16 Ga. (1.5)	400	(1.78)	50	(.22)	50	(.22)	11	(5.0)
B2030DCU	1" (25.4)	1.125	(28.6)	14 Ga. (1.9)	600	(2.67)	75	(.33)	75	(.33)	15	(6.8)
B2010DCU	1 1/4" (31.7)	1.375	(34.9)	14 Ga. (1.9)	600	(2.67)	75	(.33)	75	(.33)	17	(7.7)
B2011DCU	1 1/2" (38.1)	1.625	(41.3)	14 Ga. (1.9)	600	(2.67)	75	(.33)	75	(.33)	19	(8.6)
B2038DCU	2" (50.8)	2.125	(54.0)	12 Ga. (2.6)	800	(3.56)	125	(.56)	125	(.56)	32	(14.5)
B2042DCU	2 1/2" (63.5)	2.625	(66.7)	12 Ga. (2.6)	800	(3.56)	125	(.56)	125	(.56)	35	(15.9)
B2046DCU	3" (76.2)	3.125	(79.4)	12 Ga. (2.6)	800	(3.56)	125	(.56)	125	(.56)	39	(17.7)
B2050DCU	3 1/2" (88.9)	3.625	(92.1)	11 Ga. (3.0)	1000	(4.45)	200	(.89)	150	(.67)	54	(24.5)
B2054DCU	4" (101.6)	4.125	(104.8)	11 Ga. (3.0)	1000	(4.45)	200	(.89)	150	(.67)	61	(27.6)
B2062DCU	5" (127.0)	5.125	(130.2)	11 Ga. (3.0)	1000	(4.45)	200	(.89)	150	(.67)	70	(31.7)
B2110DCU	6" (152.5)	6.125	(155.6)	11 Ga. (3.0)	1000	(4.45)	250	(1.11)	200	(.89)	94	(42.6)
B2126DCU	8" (203.2)	8.125	(206.4)	11 Ga. (3.0)	1000	(4.45)	250	(1.11)	200	(.89)	123	(55.8)

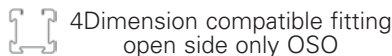

Reference page 168 for general fitting and standard finish specifications.

Pipe Clamps

B2000 Series O.D. Pipe and Conduit Clamps

- Safety Factor of 5
- Add PA to suffix for pre-assembled pipe clamps
- Other sizes available upon request
- Includes combination recess hex head machine screw and square nut.
- Material: 16 Ga. (1.5), 14 Ga. (1.9), 12 Ga. (2.6)
ASTM A653 33,000 PSI min. yield and 11 Ga. (3.0)
ASTM A1011HSLA Gr. 50
- Standard finishes: ZN, HDG, SS4

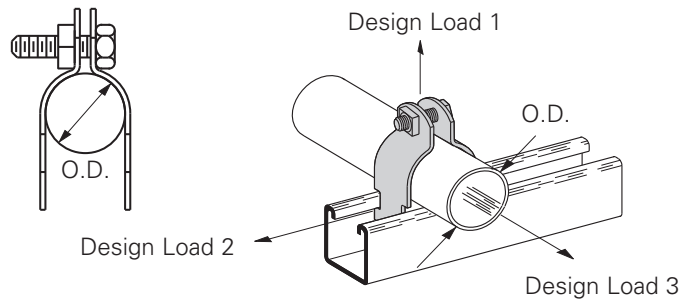

O.D. Clamps

Part No.	O.D. Size (in.)		Hardware Size	Material Gauge Thickness		Design Load 1		Design Load 2		Design Load 3		Wt./C	
	In.	mm		In.	mm	Lbs.	kN	Lbs.	kN	Lbs.	kN	Lbs.	kg
B2023	1/4"	(6.3)	1/4"-20	16	(1.5)	120	(.54)	30	(.13)	30	(.13)	8	(3.6)
B2024	3/8"	(9.5)	1/4"-20	16	(1.5)	300	(1.33)	40	(.18)	40	(.18)	8	(3.6)
B2025	1/2"	(12.7)	1/4"-20	16	(1.5)	400	(1.78)	50	(.22)	50	(.22)	9	(4.1)
B2026	5/8"	(15.9)	1/4"-20	16	(1.5)	400	(1.78)	50	(.22)	50	(.22)	10	(4.5)
B2027	3/4"	(19.0)	1/4"-20	16	(1.5)	400	(1.78)	50	(.22)	50	(.22)	10	(4.5)
B2008	7/8"	(22.2)	1/4"-20	16	(1.5)	400	(1.78)	50	(.22)	50	(.22)	11	(5.0)
B2009	1"	(25.4)	1/4"-20	14	(1.9)	500	(2.22)	75	(.33)	75	(.33)	15	(6.8)
B2030	1 1/8"	(28.6)	1/4"-20	14	(1.9)	600	(2.67)	75	(.33)	75	(.33)	15	(6.8)
B2031	1 1/4"	(31.7)	1/4"-20	14	(1.9)	600	(2.67)	75	(.33)	75	(.33)	16	(7.3)
B2010	1 3/8"	(34.9)	1/4"-20	14	(1.9)	600	(2.67)	75	(.33)	75	(.33)	17	(7.7)
B2004	1 1/2"	(38.1)	1/4"-20	14	(1.9)	600	(2.67)	75	(.33)	75	(.33)	18	(8.2)
B2011	1 5/8"	(41.3)	1/4"-20	14	(1.9)	600	(2.67)	75	(.33)	75	(.33)	19	(8.6)
B2005	1 3/4"	(44.4)	5/16"-18	12	(2.6)	800	(3.56)	125	(.56)	125	(.56)	29	(13.1)
B2012	1 7/8"	(47.6)	5/16"-18	12	(2.6)	800	(3.56)	125	(.56)	125	(.56)	30	(13.6)
B2037	2	(50.8)	5/16"-18	12	(2.6)	800	(3.56)	125	(.56)	125	(.56)	30	(13.6)
B2038	2 1/8"	(54.0)	5/16"-18	12	(2.6)	800	(3.56)	125	(.56)	125	(.56)	32	(14.5)
B2039	2 1/4"	(57.1)	5/16"-18	12	(2.6)	800	(3.56)	125	(.56)	125	(.56)	32	(14.5)
B2013	2 3/8"	(60.3)	5/16"-18	12	(2.6)	800	(3.56)	125	(.56)	125	(.56)	34	(15.4)
B2041	2 1/2"	(63.5)	5/16"-18	12	(2.6)	800	(3.56)	125	(.56)	125	(.56)	35	(15.9)
B2042	2 5/8"	(66.7)	5/16"-18	12	(2.6)	800	(3.56)	125	(.56)	125	(.56)	35	(15.9)
B2043	2 3/4"	(69.8)	5/16"-18	12	(2.6)	800	(3.56)	125	(.56)	125	(.56)	38	(17.2)
B2014	2 7/8"	(73.0)	5/16"-18	12	(2.6)	800	(3.56)	125	(.56)	125	(.56)	38	(17.2)
B2045	3	(76.2)	5/16"-18	12	(2.6)	800	(3.56)	125	(.56)	125	(.56)	38	(17.2)
B2046	3 1/8"	(79.4)	5/16"-18	12	(2.6)	800	(3.56)	125	(.56)	125	(.56)	39	(17.7)
B2047	3 1/4"	(82.5)	5/16"-18	12	(2.6)	800	(3.56)	125	(.56)	125	(.56)	41	(18.6)
B2048	3 3/8"	(85.7)	5/16"-18	12	(2.6)	800	(3.56)	125	(.56)	125	(.56)	43	(19.5)
B2015	3 1/2"	(88.9)	5/16"-18	12	(2.6)	800	(3.56)	125	(.56)	125	(.56)	44	(20.0)
B2050	3 5/8"	(92.1)	5/16"-18	11	(3.0)	1000	(4.45)	200	(.89)	150	(.67)	54	(24.5)
B2051	3 3/4"	(95.2)	5/16"-18	11	(3.0)	1000	(4.45)	200	(.89)	150	(.67)	57	(25.8)
B2052	3 7/8"	(98.4)	5/16"-18	11	(3.0)	1000	(4.45)	200	(.89)	150	(.67)	55	(25.0)
B2016	4	(101.6)	5/16"-18	11	(3.0)	1000	(4.45)	200	(.89)	150	(.67)	57	(25.8)
B2054	4 1/8"	(104.8)	5/16"-18	11	(3.0)	1000	(4.45)	200	(.89)	150	(.67)	61	(27.7)
B2055	4 1/4"	(107.9)	5/16"-18	11	(3.0)	1000	(4.45)	200	(.89)	150	(.67)	62	(28.1)
B2056	4 3/8"	(111.1)	5/16"-18	11	(3.0)	1000	(4.45)	200	(.89)	150	(.67)	64	(29.0)
B2017	4 1/2"	(114.3)	5/16"-18	11	(3.0)	1000	(4.45)	200	(.89)	150	(.67)	66	(29.9)
B2058	4 5/8"	(117.5)	5/16"-18	11	(3.0)	1000	(4.45)	200	(.89)	150	(.67)	66	(29.9)

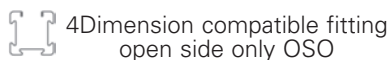

Reference page 168 for general fitting and standard finish specifications.

B2000 Series O.D. Pipe and Conduit Clamps

- Safety Factor of 5
- Add PA to suffix for pre-assembled pipe clamps
- Other sizes available upon request
- Includes combination recess hex head machine screw and square nut.
- Material: 16 Ga. (1.5), 14 Ga. (1.9), 12 Ga. (2.6)
ASTM A653 33,000 PSI min. yield and
11 Ga. (3.0) ASTM A1011HSLA Gr. 50
- Standard finishes: ZN, HDG, SS4

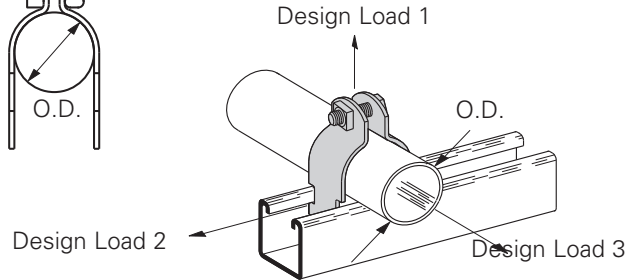
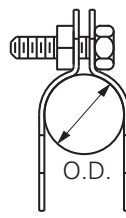

O.D. Clamps

Part No.	O.D. Size (in.)		Hardware Size	Material Gauge Thickness		Design Load 1		Design Load 2		Design Load 3		Wt./C	
	In.	mm		In.	mm	Lbs.	kN	Lbs.	kN	Lbs.	kN	Lbs.	kg
B2059	4 ³ / ₄ "	(120.6)	5/16"-18	11	(3.0)	1000	(4.45)	200	(.89)	150	(.67)	68	(30.8)
B2060	4 ⁷ / ₈ "	(123.8)	5/16"-18	11	(3.0)	1000	(4.45)	200	(.89)	150	(.67)	69	(31.3)
B2018	5	(127.0)	5/16"-18	11	(3.0)	1000	(4.45)	200	(.89)	150	(.67)	70	(31.8)
B2062	5 ¹ / ₈ "	(130.2)	5/16"-18	11	(3.0)	1000	(4.45)	200	(.89)	150	(.67)	70	(31.8)
B2063	5 ¹ / ₄ "	(133.3)	5/16"-18	11	(3.0)	1000	(4.45)	200	(.89)	150	(.67)	70	(31.8)
B2064	5 ³ / ₈ "	(136.5)	5/16"-18	11	(3.0)	1000	(4.45)	200	(.89)	150	(.67)	77	(34.9)
B2019	5 ¹ / ₂ "	(139.7)	5/16"-18	11	(3.0)	1000	(4.45)	200	(.89)	150	(.67)	78	(35.4)
B2066	5 ⁵ / ₈ "	(142.9)	3/8"-16	11	(3.0)	1000	(4.45)	200	(.89)	150	(.67)	83	(37.6)
B2067	5 ³ / ₄ "	(146.0)	3/8"-16	11	(3.0)	1000	(4.45)	200	(.89)	150	(.67)	84	(38.1)
B2068	5 ⁷ / ₈ "	(149.2)	3/8"-16	11	(3.0)	1000	(4.45)	200	(.89)	150	(.67)	85	(38.6)
B2069	6"	(152.4)	3/8"-16	11	(3.0)	1000	(4.45)	200	(.89)	150	(.67)	87	(39.5)
B2110	6 ¹ / ₈ "	(155.6)	3/8"-16	11	(3.0)	1000	(4.45)	250	(1.11)	200	(.89)	94	(42.6)
B2111	6 ¹ / ₄ "	(158.7)	3/8"-16	11	(3.0)	1000	(4.45)	250	(1.11)	200	(.89)	96	(43.5)
B2112	6 ³ / ₈ "	(161.9)	3/8"-16	11	(3.0)	1000	(4.45)	250	(1.11)	200	(.89)	98	(44.4)
B2113	6 ¹ / ₂ "	(165.1)	3/8"-16	11	(3.0)	1000	(4.45)	250	(1.11)	200	(.89)	99	(44.9)
B2020	6 ⁵ / ₈ "	(168.3)	3/8"-16	11	(3.0)	1000	(4.45)	250	(1.11)	200	(.89)	100	(45.4)
B2115	6 ³ / ₄ "	(171.4)	3/8"-16	11	(3.0)	1000	(4.45)	250	(1.11)	200	(.89)	102	(46.3)
B2116	6 ⁷ / ₈ "	(174.6)	3/8"-16	11	(3.0)	1000	(4.45)	250	(1.11)	200	(.89)	104	(47.2)
B2117	7"	(177.8)	3/8"-16	11	(3.0)	1000	(4.45)	250	(1.11)	200	(.89)	106	(48.1)
B2118	7 ¹ / ₈ "	(181.0)	3/8"-16	11	(3.0)	1000	(4.45)	250	(1.11)	200	(.89)	108	(49.0)
B2119	7 ¹ / ₄ "	(184.1)	3/8"-16	11	(3.0)	1000	(4.45)	250	(1.11)	200	(.89)	110	(49.9)
B2120	7 ³ / ₈ "	(187.3)	3/8"-16	11	(3.0)	1000	(4.45)	250	(1.11)	200	(.89)	112	(50.8)
B2121	7 ¹ / ₂ "	(190.5)	3/8"-16	11	(3.0)	1000	(4.45)	250	(1.11)	200	(.89)	114	(51.7)
B2021	7 ⁵ / ₈ "	(193.7)	3/8"-16	11	(3.0)	1000	(4.45)	250	(1.11)	200	(.89)	115	(52.2)
B2123	7 ³ / ₄ "	(196.8)	3/8"-16	11	(3.0)	1000	(4.45)	250	(1.11)	200	(.89)	117	(53.1)
B2124	7 ⁷ / ₈ "	(200.0)	3/8"-16	11	(3.0)	1000	(4.45)	250	(1.11)	200	(.89)	119	(54.0)
B2125	8"	(203.2)	3/8"-16	11	(3.0)	1000	(4.45)	250	(1.11)	200	(.89)	121	(54.9)
B2126	8 ¹ / ₈ "	(206.4)	3/8"-16	11	(3.0)	1000	(4.45)	250	(1.11)	200	(.89)	123	(55.8)
B2127	8 ¹ / ₄ "	(209.5)	3/8"-16	11	(3.0)	1000	(4.45)	250	(1.11)	200	(.89)	125	(56.7)
B2128	8 ³ / ₈ "	(212.7)	3/8"-16	11	(3.0)	1000	(4.45)	250	(1.11)	200	(.89)	126	(57.2)
B2129	8 ¹ / ₂ "	(215.9)	3/8"-16	11	(3.0)	1000	(4.45)	250	(1.11)	200	(.89)	128	(58.1)
B2022	8 ⁵ / ₈ "	(219.1)	3/8"-16	11	(3.0)	1000	(4.45)	250	(1.11)	200	(.89)	128	(58.1)
B2130	10 ³ / ₄ "	(273.0)	3/8"-16	11	(3.0)	1000	(4.45)	250	(1.11)	200	(.89)	160	(72.6)
B2132	12 ³ / ₄ "	(323.8)	3/8"-16	11	(3.0)	1000	(4.45)	250	(1.11)	200	(.89)	185	(83.9)



Reference page 168 for general fitting and standard finish specifications.

Pipe Clamps

B1508 thru B1564S Conduit/Strut Clamps

- Safety Factor of 3
- Clamps without saddles are not recommended for flexible conduit or cable
- All Sizes Include:
1/4"-20 slotted hex head machine screw
- Standard finish: ZN

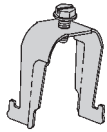
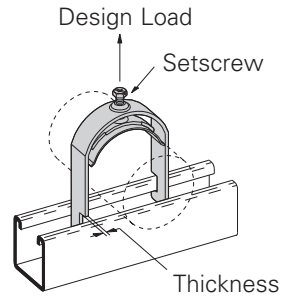

B1508 thru B1520

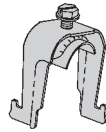

B1508S thru B1524S

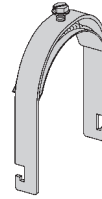

B1532S thru B1564S

Part No.	Use With				Thickness In. mm	Design Load		Wt./C	
	EMT		Rigid Conduit			Lbs.	kN	Lbs.	kg
	In.	mm	In.	mm					
B1508	1/2"	(15)	–	–	16 Ga. (1.5)	200	(.89)	7.4	(3.4)
B1512	3/4"	(20)	1/2"	(15)	16 Ga. (1.5)	200	(.89)	8.0	(3.6)
B1516	1"	(25)	3/4"	(20)	14 Ga. (1.9)	200	(.89)	11.0	(5.0)
B1520	1 1/4"	(32)	1"	(25)	14 Ga. (1.9)	200	(.89)	12.5	(5.7)
B1508S	1/2"	(15)	–	–	16 Ga. (1.5)	200	(.89)	8.6	(3.9)
B1512S	3/4"	(20)	1/2"	(15)	16 Ga. (1.5)	200	(.89)	9.2	(4.2)
B1516S	1"	(25)	3/4"	(20)	14 Ga. (1.9)	200	(.89)	12.7	(5.8)
B1520S	1 1/4"	(32)	1"	(25)	14 Ga. (1.9)	200	(.89)	14.6	(6.6)
B1524S	1 1/2"	(40)	1 1/4"	(32)	12 Ga. (2.6)	350	(1.55)	20.5	(9.3)
B1532S	2"	(50)	1 1/2"	(40)	12 Ga. (2.6)	400	(1.78)	21.5	(9.8)
B1534S	–	–	2"	(50)	12 Ga. (2.6)	400	(1.78)	22.7	(10.3)
B1540S	2 1/2"	(65)	2 1/2"	(65)	12 Ga. (2.6)	400	(1.78)	26.0	(11.9)
B1548S	3"	(80)	3"	(80)	12 Ga. (2.6)	400	(1.78)	30.2	(13.7)
B1556S	3 1/2"	(90)	3 1/2"	(90)	12 Ga. (2.6)	400	(1.78)	33.3	(15.1)
B1564S	4"	(100)	4"	(100)	12 Ga. (2.6)	400	(1.78)	36.6	(16.6)



4Dimension compatible fitting
open side only OSO

Reference page 168 for general fitting and standard finish specifications.

B2601 thru B2610 TWIST EAR™ Pipe Clamp

- One piece break apart, screw retainer, thread impressions
- Tighter alignment, no need to leave additional space between clamps in order to access nut and bolt
- Easier access bolt can be tightened directly from front
- Available in 1/2", 3/4", 1" rigid and EMT conduit
- Recommended Torque 30 in. - lbs.
- Safety Factor of 3
- Standard finish: ZN

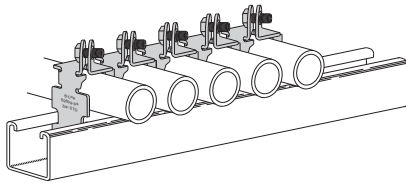

Allows for multiple clamps to be used in succession, with easier access than other pipe clamps.

Design Load

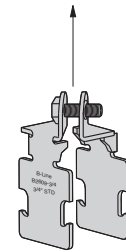

Break-apart - break in the middle, bolt the ends together.

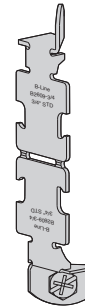

No loose pieces. One piece break apart with screw retainer and thread impressions.

Part No.	Use With		Thickness	Design Load		Wt./C		
	EMT	Rigid Conduit		Lbs.	kN	Lbs.	kg	
	In.	mm	In.	mm				
B2601	1/2"	(17.9)	—	—	300	(1.34)	8.2	(3.7)
B2602	3/4"	(23.4)	—	—	500	(2.24)	13.5	(6.1)
B2603	1"	(29.5)	—	—	500	(2.24)	15.6	(7.1)
B2608	—	—	1/2"	(21.3)	300	(1.34)	8.2	(3.7)
B2609	—	—	3/4"	(26.7)	500	(2.24)	13.5	(6.1)
B2610	—	—	1"	(33.4)	500	(2.24)	15.6	(7.1)

BP081SS thru BP475SS P Clamps

- Minimizes induction heating
- Material: Stainless Steel Type 304

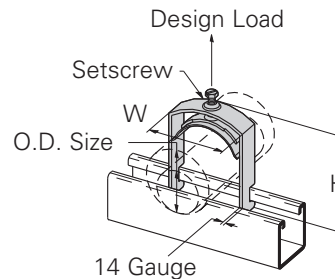

Part No.	O.D. Size		Height H		Width W		Design Load		Wt./C.	
	In.	mm	In.	mm	In.	mm	Lbs.	kN	Lbs.	kg
BP081SS	.250-.840	(6.4-21.3)	1.86	(47.2)	0.87	(22.1)	300	(1.33)	9.0	(4.1)
BP110SS	.810-1.100	(20.6-28.0)	2.18	(55.4)	1.19	(30.2)	300	(1.33)	12.0	(5.4)
BP135SS	.850-1.350	(21.6-34.8)	2.25	(57.2)	1.38	(35.1)	300	(1.33)	14.0	(6.3)
BP175SS	1.250-1.750	(31.8-44.4)	2.78	(70.6)	1.78	(45.2)	300	(1.33)	21.0	(9.5)
BP205SS	1.550-2.050	(39.4-52.1)	3.00	(76.2)	2.28	(57.9)	300	(1.33)	30.0	(13.6)
BP250SS	2.00-2.50	(50.8-63.5)	3.43	(87.1)	2.83	(71.9)	300	(1.33)	35.0	(15.9)
BP300SS	2.55-3.00	(64.7-76.2)	3.87	(97.8)	3.15	(80.0)	300	(1.33)	39.0	(17.7)
BP325SS	2.75-3.25	(69.9-82.8)	4.06	(103.1)	3.28	(83.3)	300	(1.33)	41.0	(18.6)
BP375SS	3.25-3.75	(82.6-95.3)	4.60	(116.8)	3.83	(97.3)	300	(1.33)	47.0	(21.3)
BP425SS	3.75-4.25	(95.3-108.0)	5.13	(130.3)	4.50	(114.3)	300	(1.33)	54.0	(24.4)
BP475SS	4.25-4.75	(108.0-120.7)	5.70	(144.7)	4.85	(123.2)	300	(1.33)	58.0	(26.3)

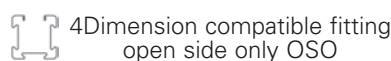

Reference page 168 for general fitting and standard finish specifications.

Vibra-Clamp Pipe Clamps

BVT Series VIBRA-CLAMP™ - Copper & O.D.

- Safety Factor of 3
- Accesses tubing sizes 1/8" (3) to 6" (150)
- Allows easy one tool installation
- Endures both high (+300°F) and low (-40°F) temperatures
- Dampens vibration and noise
- Eliminates galvanic metal to metal contact
- Resists most industrial oils and solvents
- Reduces thermal loss and gain
- Helps secure tubing firmly to channel (strut)
- Dielectric strength of 400 volts/mil
- Includes cushion, clamp, screw and nut
- Standard finishes: YZN, SS4

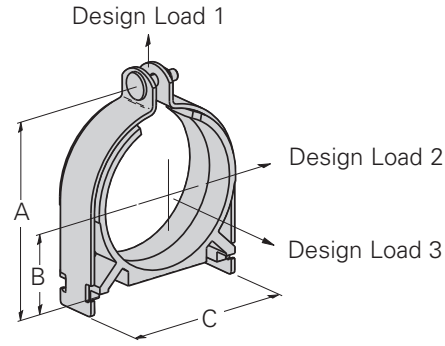

Catalog Number	Tubing O.D. Size		Copper Tubing Size		A		B		C		Wt./C	
	In.	mm	In.	mm	In.	mm	In.	mm	In.	mm	Lbs.	kg
BVT025	1/4"	(6.3)	1/8"	(3)	1.22	(30.9)	0.19	(4.8)	0.49	(12.4)	11	(5.0)
BVT037	3/8"	(9.5)	1/4"	(6)	1.36	(34.5)	0.25	(6.3)	0.61	(15.5)	12	(5.4)
BVT050	1/2"	(12.7)	3/8"	(10)	1.49	(37.8)	0.31	(7.8)	0.74	(18.8)	14	(6.3)
BVT062	5/8"	(15.9)	1/2"	(15)	1.62	(41.1)	0.38	(9.6)	0.86	(21.8)	15	(6.8)
BVT075	3/4"	(19.0)	5/8"	(17)	1.87	(47.4)	0.50	(12.7)	1.15	(29.2)	19	(8.6)
BVT087	7/8"	(22.2)	3/4"	(20)	2.00	(50.8)	0.56	(14.2)	1.27	(32.2)	21	(9.5)
BVT100	1"	(25.4)	-	-	2.25	(57.1)	0.69	(17.5)	1.52	(38.6)	22	(10.0)
BVT112	1 1/8"	(28.6)	1"	(25)	2.25	(57.1)	0.69	(17.5)	1.52	(38.6)	26	(11.8)
BVT125	1 1/4"	(31.7)	-	-	2.51	(63.7)	0.81	(20.6)	1.78	(45.2)	36	(16.3)
BVT137	1 3/8"	(34.9)	1 1/4"	(32)	2.51	(63.7)	0.81	(20.6)	1.78	(45.2)	38	(17.2)
BVT150	1 1/2"	(38.1)	-	-	2.74	(69.6)	0.88	(22.4)	1.96	(49.8)	35	(15.9)
BVT162	1 5/8"	(41.3)	1 1/2"	(40)	3.00	(76.2)	1.00	(25.4)	2.20	(55.9)	40	(18.1)
BVT175	1 3/4"	(44.4)	-	-	3.13	(79.5)	1.06	(26.9)	2.33	(59.1)	44	(19.9)
BVT187	1 7/8"	(47.6)	-	-	3.28	(83.3)	1.13	(28.7)	2.46	(62.5)	40	(18.1)
BVT200	2"	(50.8)	-	-	3.52	(89.4)	1.25	(31.7)	2.70	(68.6)	55	(25.0)
BVT212	2 1/8"	(54.0)	2"	(50)	3.52	(89.4)	1.25	(31.7)	2.70	(68.6)	55	(25.0)
BVT225	2 1/4"	(57.1)	-	-	3.64	(92.4)	1.31	(33.2)	2.83	(71.8)	54	(24.5)
BVT250	2 1/2"	(63.5)	-	-	3.91	(99.3)	1.43	(36.3)	3.11	(79.0)	56	(25.4)
BVT262	2 5/8"	(66.6)	2 1/2"	(65)	4.02	(102.1)	1.50	(38.1)	3.20	(81.3)	55	(25.0)
BVT300	3"	(76.2)	-	-	4.42	(112.2)	1.68	(42.6)	3.61	(91.6)	67	(30.4)
BVT312	3 1/8"	(79.4)	3"	(80)	4.53	(115.0)	1.75	(44.4)	3.70	(93.9)	64	(29.0)
BVT362	3 5/8"	(92.1)	3 1/2"	(90)	5.05	(128.2)	2.00	(50.8)	4.23	(107.4)	76	(34.5)
BVT412	4 1/8"	(104.8)	4"	(100)	5.55	(140.9)	2.25	(57.1)	4.73	(120.1)	93	(42.2)
BVT612	6 1/8"	(155.5)	6"	(150)	7.62	(193.5)	3.25	(82.5)	6.74	(171.1)	136	(61.6)

Catalog Number	Design Load 1		Design Load 2		Design Load 3	
	Lbs.	kN	Lbs.	kN	Lbs.	kN
BVT025	400	(1.78)	50	(0.22)	50	(0.22)
BVT037	400	(1.78)	50	(0.22)	50	(0.22)
BVT050	400	(1.78)	50	(0.22)	50	(0.22)
BVT062	400	(1.78)	50	(0.22)	50	(0.22)
BVT075	600	(2.67)	75	(0.33)	75	(0.33)
BVT087	600	(2.67)	75	(0.33)	75	(0.33)
BVT100	600	(2.67)	75	(0.33)	75	(0.33)
BVT112	600	(2.67)	75	(0.33)	75	(0.33)
BVT125	600	(2.67)	75	(0.33)	75	(0.33)
BVT137	600	(2.67)	75	(0.33)	75	(0.33)
BVT150	600	(2.67)	75	(0.33)	75	(0.33)
BVT162	800	(3.56)	125	(0.56)	125	(0.56)
BVT175	800	(3.56)	125	(0.56)	125	(0.56)
BVT187	800	(3.56)	125	(0.56)	125	(0.56)
BVT200	800	(3.56)	125	(0.56)	125	(0.56)
BVT212	800	(3.56)	125	(0.56)	125	(0.56)
BVT225	800	(3.56)	125	(0.56)	125	(0.56)
BVT250	800	(3.56)	125	(0.56)	125	(0.56)
BVT262	800	(3.56)	125	(0.56)	125	(0.56)
BVT300	800	(3.56)	125	(0.56)	125	(0.56)
BVT312	800	(3.56)	125	(0.56)	125	(0.56)
BVT362	1000	(4.45)	200	(0.89)	150	(0.67)
BVT412	1000	(4.45)	200	(0.89)	150	(0.67)
BVT612	1000	(4.45)	200	(0.89)	150	(0.67)

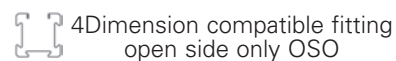

Reference page 168 for general fitting and standard finish specifications.

Vibra-Clamp Pipe Clamps

BVP Series VIBRA-CLAMP™ - Iron Pipe & Rigid Conduit

- Safety Factor of 3
- Accesses pipe sizes 1/4" (6) to 6" (150)
- Allows easy one tool installation
- Endures both high (+300°F) and low (-40°F) temperatures
- Dampens vibration and noise
- Eliminates galvanic metal to metal contact
- Resists most industrial oils and solvents
- Reduces thermal loss and gain
- Helps secure pipe firmly to channel (strut)
- Dielectric strength of 400 volts/mil
- Includes cushion, clamp, screw and nut
- Standard finishes: YZN, SS4

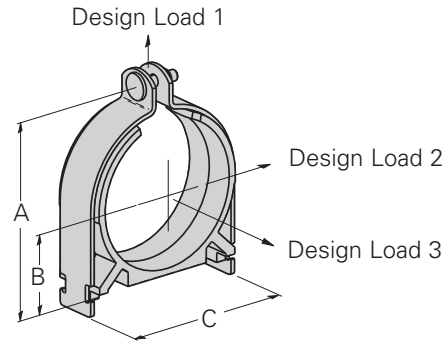

Catalog Number	Nominal Pipe Size		Steel O.D. Size		A		B		C		Wt./C	
	In.	mm	In.	mm	In.	mm	In.	mm	In.	mm	Lbs.	kg
BVP025	1/4"	(6.3)	0.540	(13.7)	1.61	(39.9)	0.37	(9.4)	0.87	(22.1)	15	(6.8)
BVP037	3/8"	(9.5)	0.675	(17.1)	1.86	(47.2)	0.50	(12.7)	1.15	(29.2)	18	(8.2)
BVP050	1/2"	(12.7)	0.875	(22.2)	1.99	(50.5)	0.56	(14.2)	1.27	(32.3)	20	(9.1)
BVP075	3/4"	(19.0)	1.050	(26.7)	2.25	(57.1)	0.69	(17.5)	1.52	(38.6)	21	(9.5)
BVP100	1"	(25.4)	1.312	(33.3)	2.51	(63.8)	0.81	(20.6)	1.77	(45.0)	20	(9.1)
BVP125	1 1/4"	(31.7)	1.660	(42.2)	3.00	(76.2)	1.00	(25.4)	2.21	(56.1)	36	(16.3)
BVP150	1 1/2"	(38.1)	1.900	(48.3)	3.21	(83.1)	1.12	(28.4)	2.41	(62.3)	40	(18.1)
BVP200	2"	(50.8)	2.375	(60.3)	3.77	(95.8)	1.37	(34.8)	2.96	(75.2)	45	(20.4)
BVP250	2 1/2"	(63.5)	2.875	(73.0)	4.28	(108.7)	1.62	(41.1)	3.46	(87.9)	54	(24.5)
BVP300	3"	(76.2)	3.500	(88.9)	5.05	(128.3)	2.00	(50.8)	4.24	(107.7)	81	(36.7)
BVP350	3 1/2"	(88.9)	4.000	(101.6)	5.55	(140.9)	2.25	(57.1)	4.74	(120.3)	87	(39.4)
BVP400	4"	(101.6)	4.500	(114.3)	6.05	(153.7)	2.50	(63.5)	5.24	(133.1)	109	(49.4)
BVP500	5"	(127.0)	5.563	(141.3)	6.84	(173.7)	3.00	(76.2)	6.24	(158.4)	136	(61.6)
BVP600	6"	(152.4)	6.625	(168.3)	8.24	(209.3)	3.56	(90.4)	7.36	(186.9)	163	(73.8)

Pipe/Conduit Clamps & Hangers

Catalog Number	Design Load 1		Design Load 2		Design Load 3	
	Lbs. 1	kN	Lbs. 2	kN	Lbs. 3	kN
BVP025	400	(1.78)	50	(0.22)	50	(0.22)
BVP037	600	(2.67)	75	(0.33)	75	(0.33)
BVP050	600	(2.67)	75	(0.33)	75	(0.33)
BVP075	600	(2.67)	75	(0.33)	75	(0.33)
BVP100	600	(2.67)	75	(0.33)	75	(0.33)
BVP125	800	(3.56)	125	(0.56)	125	(0.56)
BVP150	800	(3.56)	125	(0.56)	125	(0.56)
BVP200	800	(3.56)	125	(0.56)	125	(0.56)
BVP250	800	(3.56)	125	(0.56)	125	(0.56)
BVP300	1000	(4.45)	200	(0.89)	150	(0.67)
BVP350	1000	(4.45)	200	(0.89)	150	(0.67)
BVP400	1000	(4.45)	200	(0.89)	150	(0.67)
BVP500	1000	(4.45)	200	(0.89)	150	(0.67)
BVP600	1000	(4.45)	200	(0.89)	150	(0.67)



Reference page 168 for general fitting and standard finish specifications.

Armafix™ Clamps & Accessories

IPH Series

Inserted - Inserts with Clamps

- Engineered load-bearing inserts prevents insulation compression
- Innovative insulated pipe support
- Desirable "Foam-to-Foam" bond
- Service temperature range
-58°F (-50°C) to +220°F (+105°C)

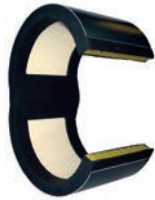

Insert Only



Assembly
Insert & Clamp



OSO

3/4" Wall Insulation Thickness

Assembly Part No.	Insert Only Part No.	Pipe/Copper/OD Size	Hanger Size*
IPH03834	IPH03834WO	3/8" O.D.	2"
IPH01234	IPH01234WO	1/2" O.D.	2"
IPH05834	IPH05834WO	5/8" O.D.	2"
IPH07834	IPH07834WO	3/4" O.D. & 7/8" O.D.	2 1/2"
IPH11834	IPH11834WO	3/4" IPS & 1 1/8" O.D.	2 1/2"
IPH13834	IPH13834WO	1 3/8" O.D.	3"
IPH15834	IPH15834WO	1 5/8" O.D.	3 1/2"
IPH11034	IPH11034WO	1 1/2" IPS & 1 7/8" O.D.	3 1/2"
IPH21834	IPH21834WO	2 1/8" O.D.	4"
IPH25834	IPH25834WO	2 5/8" O.D.	5"
IPH31834	IPH31834WO	3 1/8" O.D.	5"
IPH35834	IPH35834WO	3 5/8" O.D.	6"
IPH41834	IPH41834WO	4 1/8" O.D.	6"
IPH40034	IPH40034WO	4" IPS	6"
IPH50034	IPH50034WO	5" IPS	8"
IPH60034	IPH60034WO	6" IPS	10"
IPH80034	IPH80034WO	8" IPS	12"

* Recommended pipe hanger size for insulation thickness shown. (Order hanger separately)

IPH18230 ARMAFLEX®† Insulation Tape

- 30 ft. (9.14 M) roll



†Armaflex® is a registered trademark of Armacell.

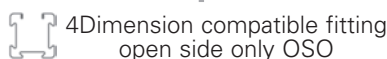

Reference page 168 for general fitting and standard finish specifications.

1/2" Wall Insulation Thickness

Assembly Part No.	Insert Only Part No.	Pipe/Copper/OD Size	Hanger Size*
IPH03812	IPH03812WO	3/8" O.D.	1 1/4"
IPH01212	IPH01212WO	1/2" O.D.	1 1/4"
IPH05812	IPH05812WO	5/8" O.D.	1 1/2"
IPH07812	IPH07812WO	3/4" O.D. & 7/8" O.D.	2"
IPH11812	IPH11812WO	3/4" IPS & 1 1/8" O.D.	2"
IPH13812	IPH13812WO	1 3/8" O.D.	2 1/2"
IPH15812	IPH15812WO	1 5/8" O.D.	2 1/2"
IPH11012	IPH11012WO	1 1/2" IPS & 1 7/8" O.D.	3"
IPH21812	IPH21812WO	2 1/8" O.D.	3"
IPH25812	IPH25812WO	2 5/8" O.D.	3 1/2"
IPH31812	IPH31812WO	3 1/8" O.D.	4"
IPH35812	IPH35812WO	3 5/8" O.D.	5"
IPH41812	IPH41812WO	4 1/8" O.D.	6"
IPH40012	IPH40012WO	4" IPS	6"
IPH50012	IPH50012WO	5" IPS	8"
IPH60012	IPH60012WO	6" IPS	8"

* Recommended pipe hanger size for insulation thickness shown. (Order hanger separately)

1" Wall Insulation Thickness

Assembly Part No.	Insert Only Part No.	Pipe/Copper/OD Size	Hanger Size*
IPH05810	IPH05810WO	5/8" O.D.	2 1/2"
IPH07810	IPH07810WO	3/4" O.D. & 7/8" O.D.	3"
IPH11810	IPH11810WO	3/4" IPS & 1 1/8" O.D.	3"
IPH13810	IPH13810WO	1 3/8" O.D.	3 1/2"
IPH15810	IPH15810WO	1 5/8" O.D.	3 1/2"
IPH11010	IPH11010WO	1 1/2" IPS & 1 7/8" O.D.	4"
IPH21810	IPH21810WO	2 1/8" O.D.	4"
IPH25810	IPH25810WO	2 5/8" O.D.	5"
IPH31810	IPH31810WO	3 1/8" O.D.	5"
IPH35810	IPH35810WO	3 5/8" O.D.	6"
IPH41810	IPH41810WO	4 1/8" O.D.	6"
IPH40010	IPH40010WO	4" IPS	8"
IPH50010	IPH50010WO	5" IPS	8"
IPH60010	IPH60010WO	6" IPS	10"
IPH80010	IPH80010WO	8" IPS	12"

* Recommended pipe hanger size for insulation thickness shown. (Order hanger separately)

B1999 VIBRA-CUSHION

- Packaged 20 Ft. (6.09 m) per carton
- Ideal isolation material
- Inhibits galvanic corrosion
- Dampens sound and vibrations
- Service Temperature Range
-75°F (-60°C) to +375°F (+199°C)
- Wt./Carton 3.8 Lbs. (1.7 kg)

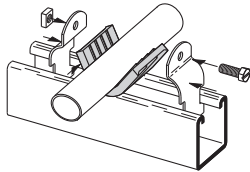

Features

Vibra-Cushion™ is designed for use with refrigeration lines, HVAC, copper tubing, glass pipe and hydraulic lines. It provides an energy-absorption barrier between the lines and the mounting material and remains flexible thru its entire service range of -75°F (-60°C) to +375°F (+199°C).

This elastomer allows for expansion and contraction within the mounting system and prevents galvanic reaction between dissimilar metals.

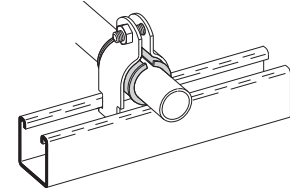

For Rigid Conduit or Iron Pipe

Nominal Size In. mm	Length*		Use Clamp No.
	In.	mm	
3/8" (10)	2 1/8"	(54.0)	B2002
1/2" (15)	2 5/8"	(66.7)	B2009
3/4" (20)	3 1/4"	(82.5)	B2031
1" (25)	4 1/8"	(104.8)	B2004
1 1/4" (32)	5 3/16"	(131.8)	B2012
1 1/2" (40)	5 15/16"	(150.8)	B2038
2" (50)	7 1/2"	(190.5)	B2042
2 1/2" (65)	9"	(228.6)	B2046
3" (80)	11"	(279.4)	B2051
3 1/2" (90)	12 1/2"	(317.5)	B2055
4" (100)	14 1/2"	(368.3)	B2059
5" (125)	17 7/16"	(442.9)	B2067
6" (150)	20 3/4"	(527.0)	B2116

* Length of Vibra-Cushion

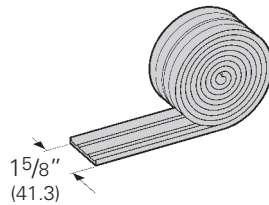

For Thinwall (EMT) Conduit

Nominal Size In. mm	Length*		Use Clamp No.
	In.	mm	
3/8" (10)	1 13/16"	(46.0)	B2027
1/2" (15)	2 13/16"	(58.7)	B2002
3/4" (20)	2 7/8"	(73.0)	B2003
1" (25)	3 5/8"	(92.1)	B2032
1 1/4" (32)	4 3/8"	(120.6)	B2036
1 1/2" (40)	5 7/16"	(138.1)	B2012
2" (50)	6 7/8"	(174.6)	B2013

* Length of Vibra-Cushion

For Copper Tubing Type L & K

Nominal Size In. mm	Length*		Use Clamp No.
	In.	mm	
1/4" (6)	1 3/16"	(30.2)	B2026
3/8" (10)	1 9/16"	(39.7)	B2027
1/2" (15)	1 7/8"	(47.6)	B2008
5/8" (17)	2 5/16"	(58.7)	B2009
3/4" (20)	2 3/4"	(69.8)	B2030
1" (25)	3 1/2"	(88.9)	B2010
1 1/4" (32)	4 5/16"	(109.5)	B2011
1 1/2" (40)	5 1/8"	(130.2)	B2012
2" (50)	6 11/16"	(169.9)	B2013
2 1/2" (65)	8 1/4"	(209.5)	B2014
3" (80)	9 13/16"	(249.2)	B2048
3 1/2" (90)	11 3/8"	(288.9)	B2052
4" (100)	12 15/16"	(328.6)	B2056
5" (125)	16 1/8"	(409.6)	B2064
6" (150)	19 1/4"	(488.9)	B2112
8" (200)	25 1/2"	(647.7)	B2128

* Length of Vibra-Cushion

ISO Pipe Isolator

- Non-adhesive rubber tape
- Fuses to itself
- Water resistant
- Ideal Isolation material
- Prevents galvanic reaction caused by dissimilar metal contact
- Temperature Range
-140°F (-60°C) to +395°F (+200°C)

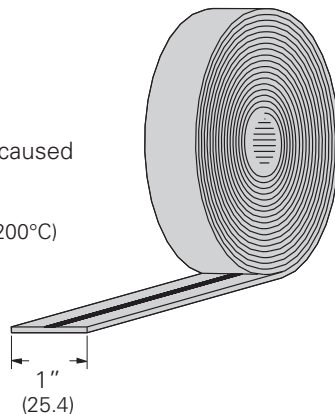

Part No.	Thickness		Ft./Roll	
	In.	mm	Ft.	m
ISO	.020	(0.5)	36	(11)

BVS Type - Vibra Strip™ for 1 5/8" (41.3) wide B-Line channel

- Fits securely in 1 5/8" wide channel
- Temperature range: -20°F to 212°F
- Ideal isolation & vibration dampening qualities
- 45 durometer hardness
- Material: Neoprene

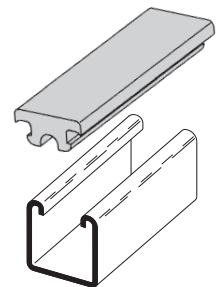

Part No.	Max. Load Lbs. per Lineal In.		Length		Std. Pkg.	Wt. Each	
	Lbs.	kg/25.4 mm	In.	mm		Lbs.	kg
BVS-12	40	(18.1)	12"	(304.8)	25	.46	(.21)
BVS-120	40	(18.1)	120"	(3048.0)	25	4.60	(2.08)

Reference page 168 for general fitting and standard finish specifications.

Pipe Clamps

B2400 Series Standard Pipe Clamp

- Safety Factor of 5
- B2400-3/4 thru B2400-8 are UL listed
- Order hardware separately
- Other sizes available upon request
- Material: Sizes - 1/2" - 1 1/2", ASTM A1011 33,000 PSI min. yield;
2" - 12", ASTM A1018 33,000 PSI min. yield;
14"-Larger, ASTM A36
- Standard finish: ZN
- Ductile iron sizes available
- Meets requirements of MSS SP-58 & SP-69 Type 26

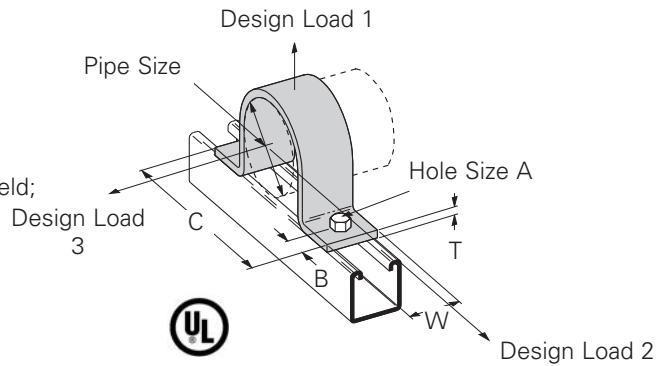

Part No.	Pipe Size		A		B		C		T		W	
	In.	mm	In.	mm	In.	mm	In.	mm	In.	mm	In.	mm
B2400-1/2	1/2"	(15)	5/16"	(7.9)	7/16"	(11.1)	2 13/16"	(71.4)	10 Ga.	(3.4)	1 5/8"	(41.3)
B2400-3/4	3/4"	(20)	5/16"	(7.9)	7/16"	(11.1)	3"	(76.2)	10 Ga.	(3.4)	1 5/8"	(41.3)
B2400-1	1"	(25)	5/16"	(7.9)	7/16"	(11.1)	3 17/32"	(89.7)	10 Ga.	(3.4)	1 5/8"	(41.3)
B2400-1 1/4	1 1/4"	(32)	5/16"	(7.9)	7/16"	(11.1)	3 3/4"	(95.2)	10 Ga.	(3.4)	1 5/8"	(41.3)
B2400-1 1/2	1 1/2"	(40)	5/16"	(7.9)	7/16"	(11.1)	4 1/16"	(103.2)	10 Ga.	(3.4)	1 5/8"	(41.3)
B2400-2	2"	(50)	7/16"	(11.1)	1 1/16"	(17.4)	5 21/32"	(143.6)	1/4"	(6.3)	1 5/8"	(41.3)
B2400-2 1/2	2 1/2"	(65)	7/16"	(11.1)	1 1/16"	(17.4)	6 5/32"	(156.3)	1/4"	(6.3)	1 5/8"	(41.3)
B2400-3	3"	(80)	7/16"	(11.1)	1 1/16"	(17.4)	6 25/32"	(172.2)	1/4"	(6.3)	1 5/8"	(41.3)
B2400-3 1/2	3 1/2"	(90)	7/16"	(11.1)	1 1/16"	(17.4)	7 9/32"	(184.9)	1/4"	(6.3)	1 5/8"	(41.3)
B2400-4	4"	(100)	9/16"	(14.3)	1 1/16"	(17.4)	7 25/32"	(197.6)	1/4"	(6.3)	1 5/8"	(41.3)
B2400-5	5"	(125)	9/16"	(14.3)	1 1/16"	(17.4)	8 7/8"	(225.4)	1/4"	(6.3)	1 5/8"	(41.3)
B2400-6	6"	(150)	9/16"	(14.3)	1 1/16"	(17.4)	9 15/16"	(252.4)	1/4"	(6.3)	1 5/8"	(41.3)
B2400-8	8"	(200)	9/16"	(14.3)	1 1/16"	(17.4)	11 31/32"	(304.0)	1/4"	(6.3)	1 5/8"	(41.3)
B2400-10	10"	(250)	9/16"	(14.3)	1 1/16"	(17.4)	14"	(355.6)	1/4"	(6.3)	1 5/8"	(41.3)
B2400-12	12"	(300)	9/16"	(14.3)	1 1/16"	(17.4)	16"	(406.4)	1/4"	(6.3)	1 5/8"	(41.3)
B2400-14	14"	(350)	1 5/16"	(23.8)	1 1/2"	(38.1)	20 3/4"	(527.0)	3/8"	(9.5)	1 3/4"	(44.4)
B2400-16	16"	(400)	1 5/16"	(23.8)	1 1/2"	(38.1)	22 3/4"	(577.8)	3/8"	(9.5)	1 3/4"	(44.4)
B2400-18	18"	(460)	1 5/16"	(23.8)	1 3/4"	(44.4)	27"	(685.8)	1/2"	(12.7)	1 3/4"	(44.4)
B2400-20	20"	(510)	1 5/16"	(23.8)	1 3/4"	(44.4)	29"	(736.6)	1/2"	(12.7)	1 3/4"	(44.4)
B2400-24	24"	(610)	1 5/16"	(23.8)	1 3/4"	(44.4)	33"	(838.2)	1/2"	(12.7)	1 3/4"	(44.4)

Part No.	Design Load 1		Design Load 2		Design Load 3		Wt./C	
	Lbs.	kN	Lbs.	kN	Lbs.	kN	Lbs.	kg
B2400-1/2	600	(2.67)	150	(.67)	105	(.47)	23	(10.4)
B2400-3/4	600	(2.67)	150	(.67)	105	(.47)	26	(11.8)
B2400-1	600	(2.67)	150	(.67)	120	(.53)	31	(14.0)
B2400-1 1/4	600	(2.67)	150	(.67)	120	(.53)	36	(16.3)
B2400-1 1/2	600	(2.67)	150	(.67)	120	(.53)	39	(17.7)
B2400-2	1200	(5.34)	480	(2.14)	180	(.80)	93	(42.2)
B2400-2 1/2	1200	(5.34)	480	(2.14)	180	(.80)	106	(48.1)
B2400-3	1200	(5.34)	480	(2.14)	300	(1.33)	132	(59.9)
B2400-3 1/2	1200	(5.34)	480	(2.14)	300	(1.33)	151	(68.5)
B2400-4	1500	(6.67)	600	(2.67)	450	(2.00)	160	(72.6)
B2400-5	1500	(6.67)	600	(2.67)	450	(2.00)	192	(87.1)
B2400-6	1500	(6.67)	600	(2.67)	450	(2.00)	219	(99.3)
B2400-8	2000	(8.90)	800	(3.56)	600	(2.67)	297	(134.7)
B2400-10	2000	(8.90)	800	(3.56)	600	(2.67)	465	(210.9)
B2400-12	2000	(8.90)	800	(3.56)	600	(2.67)	560	(254.0)
B2400-14	2000	(8.90)	800	(3.56)	600	(2.67)	761	(345.2)
B2400-16	2000	(8.90)	800	(3.56)	600	(2.67)	861	(390.5)
B2400-18	2000	(8.90)	800	(3.56)	600	(2.67)	1297	(588.3)
B2400-20	2000	(8.90)	800	(3.56)	600	(2.67)	1426	(646.8)
B2400-24	2000	(8.90)	800	(3.56)	600	(2.67)	1682	(762.9)

4Dimension compatible fitting

Reference page 168 for general fitting and standard finish specifications.

B437 Series Two Piece Pipe Clamp

- Clamp halves can turn allowing pipe to be fastened to channel at any direction
- Order hardware separately
- Standard finish: ZN



Part No.	Pipe Size		A		T		Wt./C	
	In.	mm	In.	mm	In.	mm	Lbs.	kg
B437-1/2	1/2"	(15)	5/16"	(7.9)	10 Ga.	(3.4)	22	(10.0)
B437-3/4	3/4"	(20)	5/16"	(7.9)	10 Ga.	(3.4)	26	(11.8)
B437-1	1"	(25)	5/16"	(7.9)	10 Ga.	(3.4)	30	(13.6)
B437-1 1/4	1 1/4"	(32)	5/16"	(7.9)	10 Ga.	(3.4)	35	(15.9)
B437-1 1/2	1 1/2"	(40)	5/16"	(7.9)	10 Ga.	(3.4)	38	(17.2)
B437-2	2"	(50)	7/16"	(11.1)	1 1/4"	(6.3)	91	(41.3)
B437-2 1/2	2 1/2"	(65)	7/16"	(11.1)	1 1/4"	(6.3)	104	(47.2)
B437-3	3"	(80)	7/16"	(11.1)	1 1/4"	(6.3)	130	(58.9)
B437-3 1/2	3 1/2"	(90)	7/16"	(11.1)	1 1/4"	(6.3)	149	(67.6)
B437-4	4"	(100)	9/16"	(11.1)	1 1/4"	(6.3)	158	(71.6)
B437-5	5"	(125)	9/16"	(11.1)	1 1/4"	(6.3)	190	(86.2)
B437-6	6"	(150)	9/16"	(11.1)	1 1/4"	(6.3)	217	(98.4)
B437-8	8"	(200)	9/16"	(11.1)	1 1/4"	(6.3)	295	(133.8)

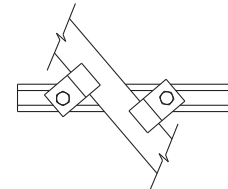
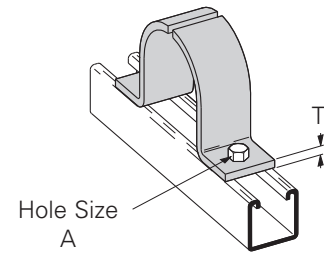

B2417 Strut Mounted Pipe Guide

- Copper tubing sizes available - B2417CT Series
- Standard finish: ZN



Part No.	Pipe Size		Minimum Radial Clearance		Includes Clamp No.	Wt./C	
	In.	mm	In.	mm		Lbs.	kg
B2417-1/2	1/2"	(15)	1/16"	(1.6)	B2009	22	(10.0)
B2417-3/4	3/4"	(20)	1/16"	(1.6)	B2010	25	(11.3)
B2417-1	1"	(25)	3/32"	(2.3)	B2034	30	(13.6)
B2417-1 1/4	1 1/4"	(32)	3/32"	(2.3)	B2037	47	(21.8)
B2417-1 1/2	1 1/2"	(40)	3/32"	(2.3)	B2039	51	(23.1)
B2417-2	2"	(50)	1/8"	(3.2)	B2043	62	(28.1)
B2417-2 1/2	2 1/2"	(65)	1/8"	(3.2)	B2047	69	(31.3)
B2417-3	3"	(80)	5/32"	(3.9)	B2016	108	(49.0)
B2417-3 1/2	3 1/2"	(90)	5/32"	(3.9)	B2017	118	(53.5)
B2417-4	4"	(100)	5/32"	(3.9)	B2018	128	(58.0)

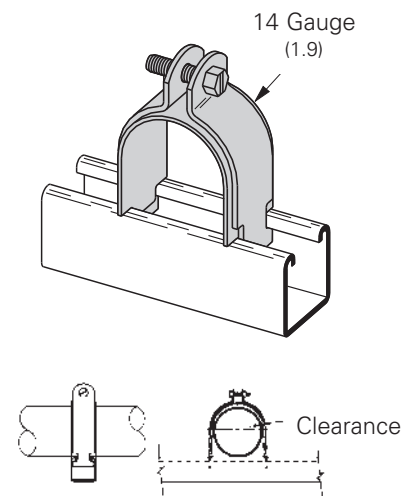

B2070 thru B2080 Parallel Pipe Clamp

- Safety Factor of 2
- Designed to support pipe or rigid conduit
- Includes:
 - 1 pr. pipe clamps
 - 1 pc. stand off plate
 - 1 pc. hotted hex head machine screws
 - 1 pc. Square Nut
- Standard finish: ZN

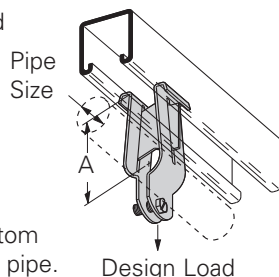

A dimension, from bottom of channel to center of pipe.

Part No.	Pipe Size		A		Material Thickness		Design Load		Wt./C	
	In.	mm	In.	mm	In.	mm	Lbs.	kN	Lbs.	kg
B2070	3/8"	(10)	1 1/16"	(42.9)	16 Ga.	(1.5)	300	(1.33)	24	(10.9)
B2071	1/2"	(15)	1 3/4"	(44.4)	16 Ga.	(1.5)	300	(1.33)	26	(11.8)
B2072	3/4"	(20)	1 7/8"	(47.6)	14 Ga.	(1.9)	300	(1.33)	30	(13.6)
B2073	1"	(25)	2"	(50.8)	14 Ga.	(1.9)	400	(1.78)	33	(14.9)
B2074	1 1/4"	(32)	2 3/16"	(55.6)	14 Ga.	(1.9)	400	(1.78)	36	(16.3)
B2075	1 1/2"	(40)	2 5/16"	(58.7)	12 Ga.	(2.6)	500	(2.22)	50	(22.7)
B2076	2"	(50)	2 9/16"	(65.1)	12 Ga.	(2.6)	500	(2.22)	55	(24.9)
B2077	2 1/2"	(65)	2 7/8"	(73.0)	12 Ga.	(2.6)	500	(2.22)	60	(27.2)
B2078	3"	(80)	3 3/16"	(80.9)	12 Ga.	(2.6)	500	(2.22)	66	(29.9)
B2079	3 1/2"	(90)	3 7/16"	(87.3)	11 Ga.	(3.0)	500	(2.22)	85	(38.5)
B2080	4"	(100)	3 5/8"	(92.1)	11 Ga.	(3.0)	500	(2.22)	95	(43.1)

4Dimension compatible fitting

Reference page 168 for general fitting and standard finish specifications.

Pipe Clamps

B670 Series Parallel Pipe Clamp

- Designed to support pipe or rigid conduit parallel to the edge of a beam or angle iron
- Hardware included
- Material: Malleable iron
- Standard finish: HDG

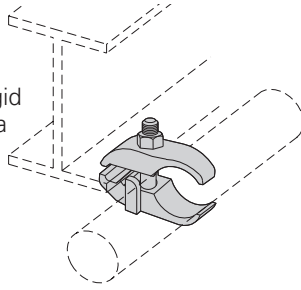

Part Number	Pipe/Conduit Size		Wt./C	
	In.	mm	Lbs.	kg
B670-3/8	3/8"	(10)	32	(14.5)
B670-1/2	1/2"	(15)	58	(26.3)
B670-3/4	3/4"	(20)	64	(29.0)
B670-1	1"	(25)	70	(31.7)
B670-1 1/4	1 1/4"	(32)	77	(34.9)
B670-1 1/2	1 1/2"	(40)	93	(42.2)
B670-2	2"	(50)	105	(47.6)
B670-2 1/2	2 1/2"	(65)	143	(64.8)
B670-3	3"	(80)	164	(74.4)
B670-3 1/2	3 1/2"	(90)	190	(86.2)
B670-4	4"	(100)	205	(93.0)

B671 Series Edge Pipe Clamp

- Designed to support pipe or rigid conduit perpendicular to the edge of a beam or angle iron
- Hardware included
- Material: Malleable iron
- Standard finish: HDG

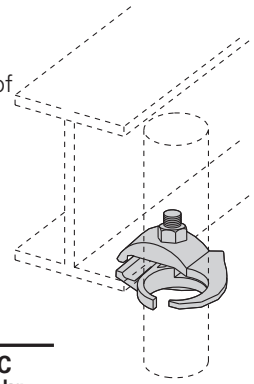

Part Number	Pipe/Conduit Size		Wt./C	
	In.	mm	Lbs.	kg
B671-1/2	1/2"	(15)	67	(30.4)
B671-3/4	3/4"	(20)	71	(32.2)
B671-1	1"	(25)	85	(38.5)
B671-1 1/4	1 1/4"	(32)	91	(41.3)
B671-1 1/2	1 1/2"	(40)	115	(52.1)
B671-2	2"	(50)	135	(61.2)
B671-2 1/2	2 1/2"	(65)	183	(83.0)
B671-3	3"	(80)	230	(104.3)

B422 Series Right Angle Clamp

- Safety Factor of 5
- Material: 7 gauge (4.5)
- Standard finishes: ZN, SS4

Part No.	Conduit Size		A	Design Load Vertical Pull		Wt./C		
	In.	mm		In.	mm	Lbs.	kg	
B422-1/2	1/2"	(15)	2 3/8"	(60.3)	250	(1.11)	38	(17.2)
B422-3/4	3/4"	(20)	2 3/8"	(60.3)	300	(1.33)	39	(17.7)
B422-1	1"	(25)	2 7/8"	(73.0)	400	(1.78)	48	(21.8)
B422-1 1/4	1 1/4"	(32)	2 7/8"	(73.0)	400	(1.78)	50	(22.7)
B422-1 1/2	1 1/2"	(40)	3 1/4"	(82.5)	500	(2.22)	59	(26.7)
B422-2	2"	(50)	3 11/16"	(93.7)	600	(2.67)	75	(34.0)
B422-2 1/2	2 1/2"	(65)	4 1/4"	(107.9)	700	(3.11)	98	(44.4)
B422-3	3"	(80)	4 7/8"	(123.8)	800	(3.56)	111	(50.3)
B422-3 1/2	3 1/2"	(90)	5 7/16"	(138.1)	900	(4.00)	123	(55.8)
B422-4	4"	(100)	6"	(152.4)	1000	(4.45)	135	(61.2)

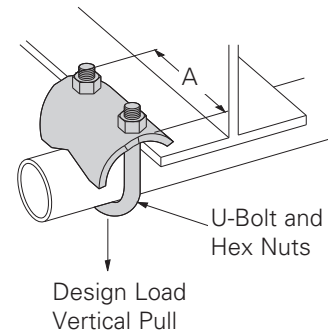

B3367S Retaining Strap

- Available in 'L' lengths of 6" (152.4), 8" (203.2), 9" (228.6), 10" (254.0), 12" (304.8), 14" (355.6), 16" (406.4), 18" (457.2)
- Material: Steel
- Standard finishes: ZN, PLN

Part No.	For Use With	Wt./C**	
		Lbs.	kg
B3367S-1-L	B422-1/2 & 3/4	33.4	(5.8)
B3367S-2-L	B422-1, 1 1/4 & 1 1/2	12.8	(15.1)

** Wt./C based on 6" (152.4) length. For each additional inch in strap length add the following to the Wt./C.
 For B3367S-1 add 5.7 Lbs (2.6 kg)
 For B3367S-2 add 2.2 Lbs (1.0 kg)

Note: Use Fig. 69 (Old B3367-3/8 retaining strap, page 116) for B422-2 thru 4

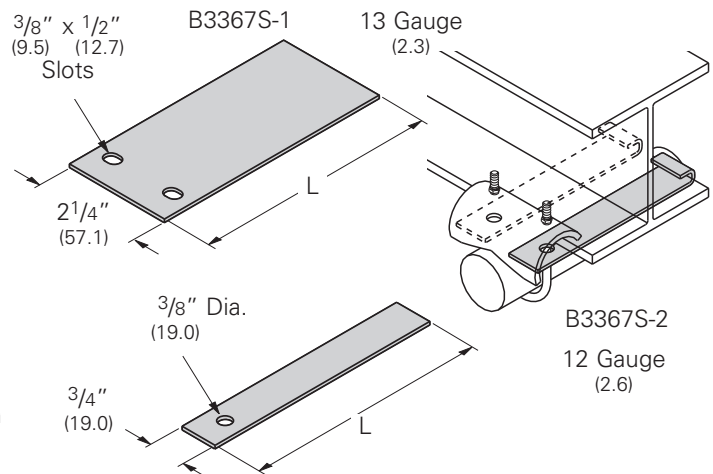

Reference page 168 for general fitting and standard finish specifications.

B2301 Series One Hole EMT Strap

- Standard finish: ZN

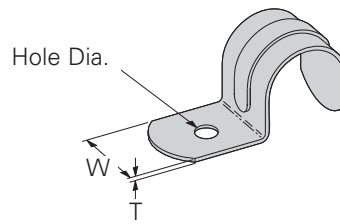

Part No.	Conduit Size		T		W		Hole Dia.		Wt./C	
	In.	mm	In.	mm	In.	mm	In.	mm	Lbs.	kg
B2301-1/2	1/2"	(15)	.050	(1.3)	3/4"	(19.0)	9/32"	(7.1)	2.4	(1.1)
B2301-3/4	3/4"	(20)	.050	(1.3)	7/8"	(22.2)	9/32"	(7.1)	4.2	(1.9)
B2301-1	1"	(25)	.050	(1.3)	1"	(25.4)	9/32"	(7.1)	8.3	(3.7)
B2301-1 1/4	1 1/4"	(32)	.065	(1.6)	1 1/4"	(31.7)	9/32"	(7.1)	11.0	(5.0)
B2301-1 1/2	1 1/2"	(40)	.090	(2.3)	1"	(25.4)	1 1/32"	(8.7)	14.8	(6.7)
B2301-2	2"	(50)	.090	(2.3)	1 1/4"	(31.7)	1 3/32"	(10.3)	21.6	(9.8)

B2302 Series One Hole Rigid Conduit/Pipe Strap

- Standard finish: ZN

Part No.	Conduit/Pipe Size		T		W		Hole Dia.		Wt./C	
	In.	mm	In.	mm	In.	mm	In.	mm	Lbs.	kg
B2302-1/4	1/4"	(6)	.045	(1.1)	5/8"	(15.9)	13/64"	(5.1)	1.4	(.6)
B2302-3/8	3/8"	(10)	.050	(1.3)	3/4"	(19.0)	9/32"	(7.1)	2.4	(1.1)
B2302-1/2	1/2"	(15)	.050	(1.3)	7/8"	(22.2)	9/32"	(7.1)	3.3	(1.5)
B2302-3/4	3/4"	(20)	.050	(1.3)	7/8"	(22.2)	9/32"	(7.1)	3.8	(1.7)
B2302-1	1"	(25)	.065	(1.6)	1"	(25.4)	9/32"	(7.1)	7.2	(3.2)
B2302-1 1/4	1 1/4"	(32)	.065	(1.6)	1 1/4"	(31.7)	2 1/64"	(8.3)	11.0	(5.0)
B2302-1 1/2	1 1/2"	(40)	11 Ga.	(3.0)	1"	(25.4)	.380	(9.6)	19.2	(8.7)
B2302-2	2"	(50)	11 Ga.	(3.0)	1 1/4"	(31.7)	.389	(9.9)	28.8	(13.0)
B2302-2 1/2	2 1/2"	(65)	7 Ga.	(4.5)	1 1/4"	(31.7)	.665	(16.9)	55.2	(25.0)
B2302-3	3"	(80)	7 Ga.	(4.5)	1 1/4"	(31.7)	.650	(16.5)	68.0	(30.8)
B2302-3 1/2	3 1/2"	(90)	1/4"	(6.3)	1 1/4"	(31.7)	.622	(15.8)	96.0	(43.5)
B2302-4	4"	(100)	1/4"	(6.3)	1 1/4"	(31.7)	.630	(16.0)	108.0	(49.0)

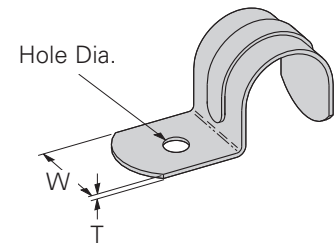

B2084 thru B2091 One Hole O.D. Tubing Clamp

- Material: 14 Gauge (1.9) ASTM A1011 33,000 PSI min. yield
- Standard finish: ZN



Part No.	O.D. Size		A		Wt./C	
	In.	mm	In.	mm	Lbs.	kg
B2084	1/4"	(6.3)	7/8"	(22.2)	4.0	(1.8)
B2085	5/16"	(7.9)	29/32"	(23.0)	4.2	(1.9)
B2086	3/8"	(9.5)	31/32"	(24.6)	5.2	(2.3)
B2087	1/2"	(12.7)	1 1/16"	(25.9)	5.8	(2.6)
B2088	5/8"	(15.9)	1 3/32"	(27.8)	7.1	(3.2)
B2089	3/4"	(19.0)	1 5/32"	(29.1)	7.7	(3.5)
B2090	7/8"	(22.2)	1 7/32"	(30.7)	8.7	(3.9)
B2091	1"	(25.4)	1 9/32"	(32.2)	10.0	(4.5)

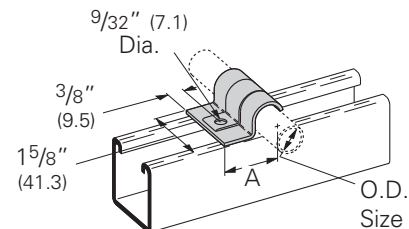

4Dimension compatible fitting

Reference page 168 for general fitting and standard finish specifications.

Pipe Clamps

BL1400 Series Conduit Hanger

- Safety Factor of 3
- Unless noted all sizes fit both rigid (R) and thinwall (EMT) conduit
- Hardware included
- Standard finishes: ZN, SS4

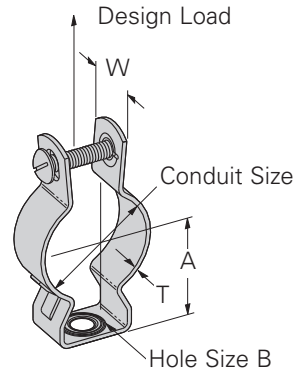

Part No	Conduit Size	A		B		T		W		Design Load		Wt./C	
		In.	mm	In.	mm	In.	mm	In.	mm	Lbs.	kN	Lbs.	kg
BL1400	1/2" EMT & Rigid	29/32"	(23.0)	9/32"	(7.1)	16 Ga.	(1.5)	3/4"	(19.0)	590	(2.62)	6	(2.7)
BL1410	3/4" EMT & Rigid	31/32"	(24.6)	9/32"	(7.1)	16 Ga.	(1.5)	3/4"	(19.0)	590	(2.62)	7	(3.2)
BL1420	1" EMT & Rigid	1 1/4"	(31.7)	9/32"	(7.1)	16 Ga.	(1.5)	3/4"	(19.0)	590	(2.62)	8	(3.6)
BL1425	1 1/4" EMT	1 1/4"	(31.7)	9/32"	(7.1)	18 Ga.	(1.2)	7/8"	(22.2)	590	(2.62)	10	(4.5)
BL1430	1 1/4" Rigid, 1 1/2" EMT	1 13/32"	(35.7)	9/32"	(8.7)	18 Ga.	(1.2)	7/8"	(22.2)	590	(2.62)	10	(4.5)
BL1440	1 1/2" Rigid	1 5/8"	(41.3)	1 1/32"	(8.7)	16 Ga.	(1.5)	1"	(25.4)	755	(3.36)	17	(7.7)
BL1450	2" EMT & Rigid	2 1/16"	(47.6)	1 1/32"	(8.7)	16 Ga.	(1.5)	1 1/4"	(31.7)	755	(3.36)	25	(11.3)
BL1460	2 1/2" EMT & Rigid	2 1/16"	(52.4)	1 1/32"	(8.7)	16 Ga.	(1.5)	1 1/4"	(31.7)	755	(3.36)	26	(11.8)
BL1470	3" EMT & Rigid	2 1/2"	(63.5)	1 1/32"	(8.7)	16 Ga.	(1.5)	1 1/4"	(31.7)	820	(3.65)	33	(14.9)
BL1480	3 1/2" EMT & Rigid	2 3/4"	(69.8)	1 1/32"	(8.7)	16 Ga.	(1.5)	1 1/4"	(31.7)	850	(3.78)	36	(16.3)
BL1490	4" EMT & Rigid	3 1/2"	(88.9)	1 1/32"	(8.7)	16 Ga.	(1.5)	1 1/4"	(31.7)	1410	(6.27)	40	(18.1)

B3373 Series Riser Clamp

- Safety Factor of 3.5
- B3373-3/4 thru B3373-8 are UL Listed
- B3373-3/4 thru B3373-6 are FM Approved
- Includes hex head cap screws and hex nuts
- Standard finishes: ZN, PLN

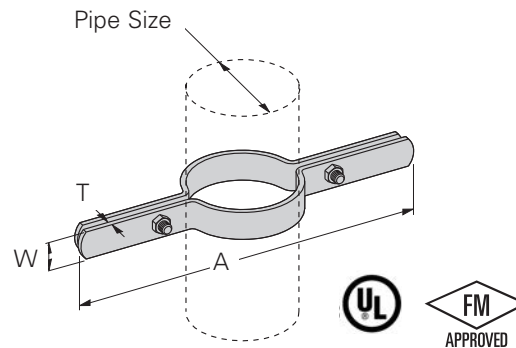

Part No.	Pipe Size		A		Design Load		Wt./C	
	In.	mm	In.	mm	Lbs.	kN	Lbs.	kg
B3373-1/2	1/2"	(15)	9"	(228.6)	255	(1.13)	101	(45.9)
B3373-3/4	3/4"	(20)	9 1/4"	(234.9)	255	(1.13)	105	(47.7)
B3373-1	1"	(25)	9 9/16"	(242.9)	255	(1.13)	109	(49.4)
B3373-1 1/4	1 1/4"	(32)	10"	(254.0)	255	(1.13)	112	(50.9)
B3373-1 1/2	1 1/2"	(32)	10 1/4"	(260.3)	255	(1.13)	113	(51.1)
B3373-2	2"	(40)	10 3/4"	(273.0)	255	(1.13)	165	(75.0)
B3373-2 1/2	2 1/2"	(50)	11 1/4"	(285.7)	390	(1.73)	180	(81.6)
B3373-3	3"	(65)	11 15/16"	(303.2)	530	(2.36)	195	(88.4)
B3373-3 1/2	3 1/2"	(80)	12 3/8"	(314.3)	670	(2.98)	217	(98.5)
B3373-4	4"	(90)	12 7/8"	(327.0)	810	(3.60)	228	(103.5)
B3373-5	5"	(100)	14"	(355.6)	1160	(5.16)	480	(217.7)
B3373-6	6"	(100)	15 3/16"	(385.8)	1570	(6.98)	526	(238.6)
B3373-8	8"	(100)	17 3/4"	(450.8)	2500	(11.12)	957	(434.1)

Reference page 168 for general fitting and standard finish specifications.

B3690 Series Adjustable J Hanger

- Safety Factor of 5
- Material:
 - 12 Ga. (2.6) ASTM A1011 33,000 PSI min. yield
 - 11 Ga. (3.0) ASTM A1011 HSLA Gr. 50 Class 1
 - 7 Ga. (4.5) ASTM A1011 33,000 PSI min. yield and 1/4" (6.3) ASTM A1018 33,000 PSI min. yield
- Standard finish: ZN

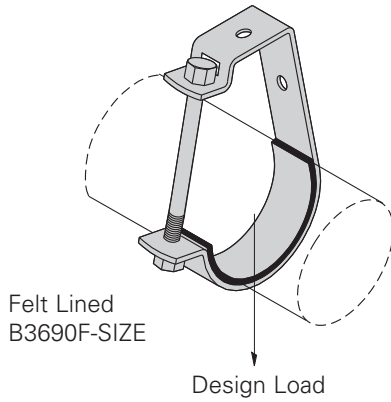

'E' Diameter. Is For Wall Mounting

Bolt Size 'F' and Hex Nut Included

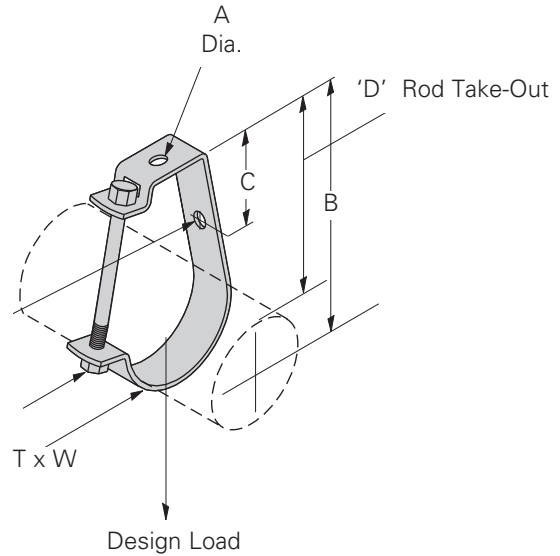

Part No.	Pipe or Conduit Size		A		B		C		D		E	
	In.	mm	In.	mm	In.	mm	In.	mm	In.	mm	In.	mm
B3690-1/2	1/2"	(15)	13/32"	(10.3)	23/32"	(53.2)	1"	(25.4)	1 11/16"	(42.5)	13/32"	(10.3)
B3690-3/4	3/4"	(20)	13/32"	(10.3)	2 11/32"	(59.5)	1"	(25.4)	1 13/16"	(46.2)	13/32"	(10.3)
B3690-1	1"	(25)	13/32"	(10.3)	2 19/32"	(65.9)	1"	(25.4)	1 15/16"	(49.2)	13/32"	(10.3)
B3690-1 1/4	1 1/4"	(32)	13/32"	(10.3)	2 13/16"	(71.4)	1"	(25.4)	2"	(50.4)	13/32"	(10.3)
B3690-1 1/2	1 1/2"	(40)	13/32"	(10.3)	3 1/16"	(77.8)	1"	(25.4)	2 1/8"	(53.7)	13/32"	(10.3)
B3690-2	2"	(50)	13/32"	(10.3)	3 1/2"	(88.9)	1"	(25.4)	2 5/16"	(58.7)	13/32"	(10.3)
B3690-2 1/2	2 1/2"	(65)	9/16"	(14.3)	4 7/16"	(112.7)	1"	(25.4)	3"	(76.2)	9/16"	(14.3)
B3690-3	3"	(80)	9/16"	(14.3)	4 7/8"	(123.8)	1"	(25.4)	3 1/8"	(79.4)	9/16"	(14.3)
B3690-3 1/2	3 1/2"	(90)	9/16"	(14.3)	5 3/16"	(131.8)	1"	(25.4)	3 3/16"	(81.0)	9/16"	(14.3)
B3690-4	4"	(100)	1 1/16"	(17.5)	6 1/8"	(155.6)	1 1/4"	(31.8)	3 7/8"	(98.4)	9/16"	(14.3)
B3690-5	5"	(125)	1 1/16"	(17.5)	6 3/4"	(171.4)	1 1/2"	(38.1)	4"	(100.8)	9/16"	(14.3)
B3690-6	6"	(150)	1 3/16"	(20.6)	7 3/4"	(196.8)	1 3/16"	(30.2)	4 7/16"	(112.7)	9/16"	(14.3)
B3690-8	8"	(200)	1 3/16"	(20.6)	9 1/4"	(235.0)	1"	(25.4)	4 15/16"	(125.4)	9/16"	(14.3)

Part No.	F Bolt Size	T		W		Design Load		Wt./C	
		In.	mm	In.	mm	Lbs.	kN	Lbs.	kg
B3690-1/2	1/4"-20 x 2 1/4"	12 Ga.	(2.6)	3/4"	(19.0)	400	(1.78)	20	(9.1)
B3690-3/4	1/4"-20 x 2 1/2"	12 Ga.	(2.6)	3/4"	(19.0)	400	(1.78)	23	(10.4)
B3690-1	1/4"-20 x 2 3/4"	12 Ga.	(2.6)	3/4"	(19.0)	400	(1.78)	24	(10.9)
B3690-1 1/4	1/4"-20 x 3"	12 Ga.	(2.6)	3/4"	(19.0)	400	(1.78)	27	(12.2)
B3690-1 1/2	1/4"-20 x 3 1/4"	12 Ga.	(2.6)	3/4"	(19.0)	400	(1.78)	29	(13.1)
B3690-2	1/4"-20 x 3 1/2"	12 Ga.	(2.6)	3/4"	(19.0)	400	(1.78)	32	(14.5)
B3690-2 1/2	3/8"-16 x 4 1/2"	11 Ga.	(3.0)	1 1/4"	(31.7)	800	(3.56)	71	(32.2)
B3690-3	3/8"-16 x 5"	11 Ga.	(3.0)	1 1/4"	(31.7)	800	(3.56)	77	(34.9)
B3690-3 1/2	3/8"-16 x 5 1/2"	11 Ga.	(3.0)	1 1/4"	(31.7)	800	(3.56)	84	(38.1)
B3690-4	3/8"-16 x 6 1/2"	7 Ga.	(4.5)	1 1/4"	(31.7)	800	(3.56)	139	(63.0)
B3690-5	3/8"-16 x 7 1/2"	7 Ga.	(4.5)	1 1/4"	(31.7)	800	(3.56)	166	(75.3)
B3690-6	3/8"-16 x 8 1/2"	1/4"	(6.3)	1 1/4"	(31.7)	1000	(4.45)	226	(102.5)
B3690-8	3/8"-16 x 10 1/2"	1/4"	(6.3)	1 1/2"	(38.1)	1200	(5.34)	332	(150.6)

Reference page 168 for general fitting and standard finish specifications.

Pipe Hangers

**Fig. 4B Series (Formerly B386 Series)
Suspension Rod Pipe Strap**

- Safety Factor of 3
- Includes hex head cap screws and hex nuts
- Standard finishes: ZN, GRN

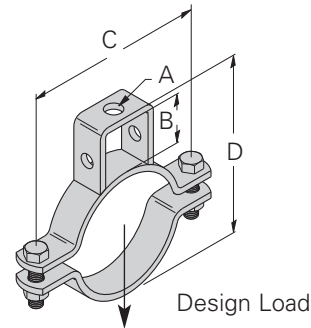

Part No.	Pipe Size		Rod Size		B		C		D		Bolt Size	Design Load		Wt./C	
	in.	mm	A		in.	mm	in.	mm	in.	mm		Lbs.	kN	Lbs.	kg
4B-3/4	3/4"	(20)	3/8"-16		1"	(25.4)	27/8"	(73.0)	25/8"	(66.7)	5/16"-18	330	(1.47)	56	(3.6)
4B-1	1"	(25)	3/8"-16		1"	(25.4)	31/4"	(82.5)	215/16"	(74.6)	5/16"-18	330	(1.47)	60	(3.6)
4B-11/4	11/4"	(32)	3/8"-16		1"	(25.4)	39/16"	(90.6)	31/4"	(82.5)	5/16"-18	330	(1.47)	74	(4.5)
4B-11/2	11/2"	(40)	3/8"-16		1"	(25.4)	313/16"	(96.8)	37/16"	(87.3)	5/16"-18	330	(1.47)	79	(5.0)
4B-2	2"	(50)	3/8"-16		1 1/2"	(38.1)	5 1/8"	(130.2)	4 5/8"	(117.5)	5/16"-18	440	(1.78)	156	(5.0)
4B-2 1/2	2 1/2"	(65)	1/2"-13		1 3/4"	(44.4)	5 5/8"	(142.9)	5 3/8"	(136.5)	3/8"-16	440	(1.78)	176	(5.4)
4B-3	3"	(80)	1/2"-13		1 7/8"	(47.6)	6 3/4"	(171.4)	6 1/8"	(155.5)	3/8"-16	660	(2.93)	198	(6.3)
4B-3 1/2	3 1/2"	(90)	1/2"-13		2"	(50.8)	7 1/4"	(184.1)	6 3/4"	(171.4)	3/8"-16	660	(2.93)	219	(7.2)
4B-4	4"	(100)	5/8"-11		2"	(50.8)	8 5/8"	(219.1)	7 1/4"	(184.1)	2 1/2"-13	800	(3.56)	288	(8.1)
4B-5	5"	(125)	5/8"-11		2"	(50.8)	9 7/8"	(250.8)	8 5/16"	(211.1)	5/8"-11	980	(4.36)	390	(8.1)
4B-6	6"	(150)	3/4"-10		2 1/8"	(54.0)	10 15/16"	(277.8)	9 1/2"	(241.3)	5/8"-11	980	(4.36)	448	(8.1)
4B-8	8"	(200)	7/8"-9		2 1/8"	(54.0)	13 7/16"	(341.2)	11 1/2"	(292.1)	3/4"-10	1200	(5.34)	691	(8.1)

**B394 Series
Pipe Strap**

- Safety Factor of 3
- Includes:
 - 1 Pair pipe clamps with hex head cap screws and hex nuts
 - 1 Hanger strap
- Standard finishes: ZN

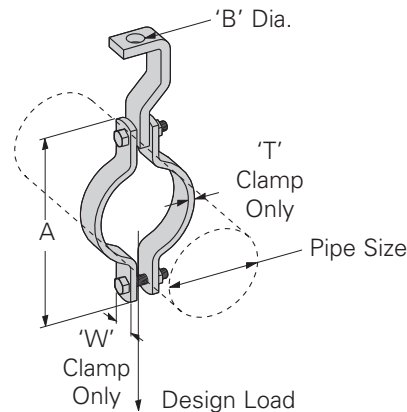

Part No.	Pipe Size		A		B		T		W		Design Load		Wt./C	
	in.	mm	in.	mm	in.	mm	in.	mm	in.	mm	Lbs.	kN	Lbs.	kg
B394-3/4	3/4"	(20)	35/16"	(84.1)	7/16"	(11.1)	1/8"	(3.2)	1"	(25.4)	500	(2.22)	71	(32.2)
B394-1	1"	(25)	33/4"	(95.2)	7/16"	(11.1)	1/8"	(3.2)	1"	(25.4)	500	(2.22)	76	(34.5)
B394-11/4	1 1/4"	(32)	4"	(101.6)	7/16"	(11.1)	1/8"	(3.2)	1"	(25.4)	500	(2.22)	77	(34.9)
B394-1 1/2	1 1/2"	(40)	4 5/16"	(109.5)	7/16"	(11.1)	1/8"	(3.2)	1"	(25.4)	800	(3.56)	79	(35.8)
B394-2	2"	(50)	5 1/2"	(139.7)	7/16"	(11.1)	1/4"	(6.3)	1"	(25.4)	1040	(4.62)	166	(75.3)
B394-2 1/2	2 1/2"	(65)	6 3/8"	(161.9)	9/16"	(14.3)	1/4"	(6.3)	1"	(25.4)	1040	(4.62)	179	(81.2)
B394-3	3"	(80)	7"	(177.8)	9/16"	(14.3)	1/4"	(6.3)	1"	(25.4)	1040	(4.62)	190	(86.2)
B394-3 1/2	3 1/2"	(90)	7 9/16"	(192.1)	9/16"	(14.3)	1/4"	(6.3)	1"	(25.4)	1040	(4.62)	203	(92.1)
B394-4	4"	(100)	8 5/8"	(219.1)	1 1/16"	(17.4)	1/4"	(6.3)	1 1/4"	(31.7)	1040	(4.62)	320	(145.1)
B394-5	5"	(125)	9 3/4"	(247.6)	1 1/16"	(17.4)	1/4"	(6.3)	1 1/4"	(31.7)	1040	(4.62)	353	(160.1)
B394-6	6"	(150)	11 5/8"	(295.3)	13/16"	(20.6)	3/8"	(9.5)	1 1/2"	(38.1)	1615	(7.18)	637	(288.9)
B394-8	8"	(200)	13 7/8"	(352.4)	13/16"	(20.6)	3/8"	(9.5)	1 1/2"	(38.1)	1615	(7.18)	837	(379.6)

Reference page 168 for general fitting and standard finish specifications.

B591 Series Pipe Bracket Saddle and Clamp

- Safety Factor of 3
- Inside brace not required on B591-2 and B591-2 1/2
- Includes:
 - 1 pc. Saddle bottom
 - 1 pc. Saddle top (clamp)
 - 2 pcs. Hex head cap screws
 - 2 pcs. Hex nuts
- Standard finish: ZN

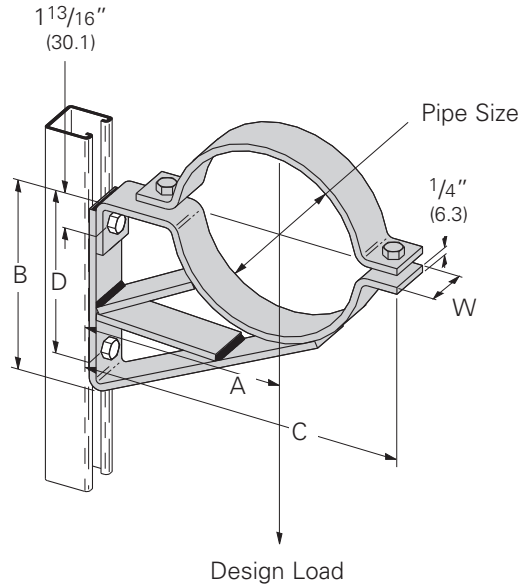

Part No.	Pipe Size		A		B		C		D		W		Design Load		Wt./C	
	In.	mm	In.	mm	In.	mm	In.	mm	In.	mm	In.	mm	Lbs.	kN	Lbs.	kg
B591-2	2"	(50)	4 1/2"	(114.3)	4 1/2"	(114.3)	7 3/16"	(182.6)	3 1/16"	(77.8)	1 5/8"	(41.3)	1235	(5.53)	290	(131.5)
B591-2 1/2	2 1/2"	(65)	5"	(127.0)	5"	(127.0)	7 15/16"	(201.6)	3 9/16"	(90.5)	1 5/8"	(41.3)	1180	(5.29)	330	(149.7)
B591-3	3"	(80)	5 1/2"	(139.7)	5 3/4"	(146.0)	8 3/4"	(222.2)	3 13/16"	(96.8)	1 5/8"	(41.3)	1125	(5.04)	439	(199.1)
B591-3 1/2	3 1/2"	(90)	6"	(152.4)	6 3/4"	(171.4)	9 1/2"	(241.3)	4 9/16"	(115.9)	1 5/8"	(41.3)	1070	(4.79)	490	(222.2)
B591-4	4"	(100)	6 1/2"	(165.1)	6 3/4"	(171.4)	10 1/4"	(260.3)	6 1/16"	(128.6)	1 5/8"	(41.3)	1015	(4.55)	545	(247.2)
B591-5	5"	(125)	7 1/2"	(190.5)	8"	(203.2)	12 1/8"	(308.0)	6 1/16"	(154.0)	1 5/8"	(41.3)	960	(4.30)	666	(302.1)
B591-6	6"	(150)	8"	(203.2)	8 3/4"	(222.2)	13 3/16"	(335.0)	6 13/16"	(173.0)	1 5/8"	(41.3)	905	(4.05)	724	(328.4)
B591-8	8"	(200)	9"	(228.6)	10 1/2"	(266.7)	15 9/16"	(395.3)	8 9/16"	(217.5)	2"	(50.8)	850	(3.81)	1087	(493.0)

4Dimension compatible fitting

Reference page 168 for general fitting and standard finish specifications.

Pipe Block

B356

Pipe Block - 2" (50) to 8" (200) Pipe

- Required hardware not included:
 - 1 pc. $\frac{3}{8}$ "-16 x 1" Hex head cap screw
 - 1 pc. $\frac{3}{8}$ "-16 Channel nut
- Material: $\frac{1}{4}$ " (6.3) thick $1\frac{5}{8}$ " (41.3) wide
ASTM A1018 33,000 PSI min. yield
- Standard finish: ZN
- Wt./C 42 Lbs. (19.0 kg) Per pair

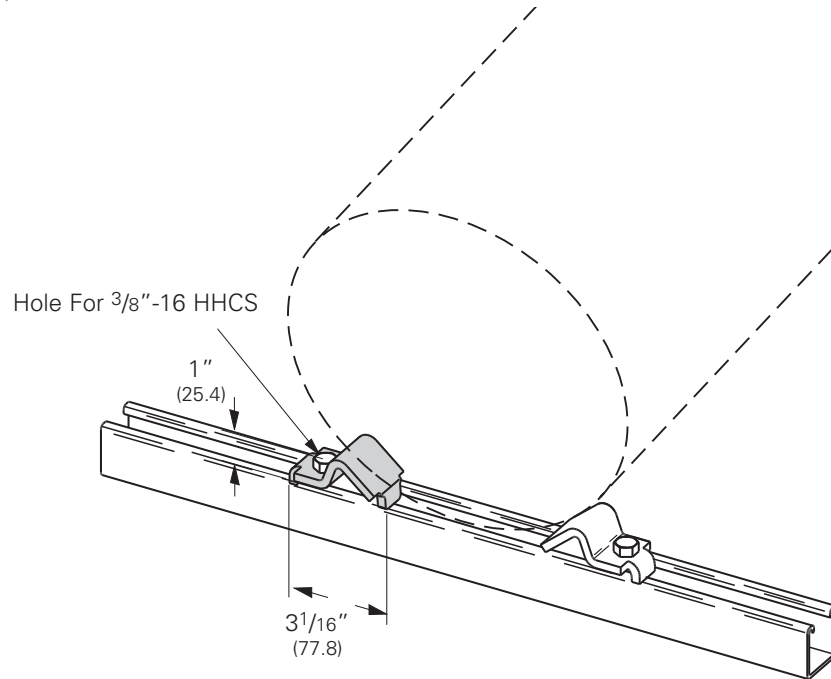

4Dimension compatible fitting

Reference page 168 for general fitting and standard finish specifications.

B218

Pipe Rollers - 1/2" (15) to 8" (200) Pipe

- Design Load 500 Lbs. (2.22 kN)
- Safety Factor of 5
- When used with B3160 thru B3165 Saddles (see Pipe Hanger Catalog)
- Malleable iron rollers
- Sold in pairs
- Required hardware not included:
2 pcs. 1/2"-13 x 1 1/4" Hex head cap screws
2 pcs. 1/2"-13 Channel nuts
- Standard finish: ZN
- Wt./C 256 Lbs. (116.1 kg) Per pair

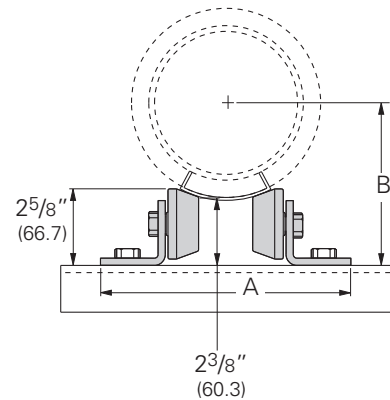
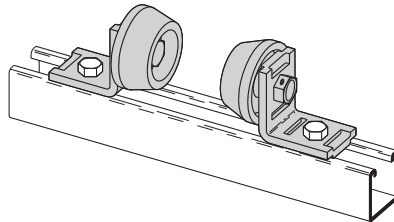

Reference Chart - A Dimension

Pipe Size	Insulation Thickness in. (mm)						
	0" (0.0)	1" (25.4)	1 1/2" (38.1)	2" (50.8)	2 1/2" (63.5)	3" (76.2)	4" (101.6)
1/2" (15)	7 1/4" (184.1)	-	-	-	-	-	-
3/4" (20)	7 1/4" (184.1)	7 1/4" (184.1)	7 5/8" (193.7)	8" (203.2)	-	-	-
1" (25)	7 1/4" (184.1)	7 1/4" (184.1)	7 5/8" (193.7)	8 1/4" (209.5)	-	-	-
1 1/4" (32)	7 1/4" (184.1)	7 1/4" (184.1)	8" (203.2)	8 1/4" (209.5)	-	-	-
1 1/2" (40)	7 1/4" (184.1)	7 5/8" (193.7)	8" (203.2)	8 1/2" (215.9)	9" (228.6)	-	-
2" (50)	7 1/4" (184.1)	7 5/8" (193.7)	8 1/2" (215.9)	8 1/2" (215.9)	9" (228.6)	-	-
2 1/2" (65)	7 1/4" (184.1)	8" (203.2)	8 1/2" (215.9)	9" (228.6)	10" (254.0)	-	-
3" (80)	7 1/4" (184.1)	8 1/2" (215.9)	9" (228.6)	9" (228.6)	10" (254.0)	10" (254.0)	-
3 1/2" (90)	7 1/4" (184.1)	8 1/2" (215.9)	9" (228.6)	10" (254.0)	10" (254.0)	10" (254.0)	-
4" (100)	7 5/8" (193.7)	9" (228.6)	9" (228.6)	10" (254.0)	10" (254.0)	11" (279.4)	-
5" (125)	8 1/2" (215.9)	9" (228.6)	10" (254.0)	10" (254.0)	11" (279.4)	11" (279.4)	12" (304.8)
6" (150)	9" (228.6)	10" (254.0)	10" (254.0)	11" (279.4)	11" (279.4)	11" (279.4)	12" (304.8)
8" (200)	10" (254.0)	11" (279.4)	11" (279.4)	11" (279.4)	12" (304.8)	-	-

Reference Chart - B Dimension

Pipe Size	Insulation Thickness in. (mm)						
	0" (0.0)	1" (25.4)	1 1/2" (38.1)	2" (50.8)	2 1/2" (63.5)	3" (76.2)	4" (101.6)
1/2" (15)	2 11/16" (68.3)	-	-	-	-	-	-
3/4" (20)	2 13/16" (71.4)	3 7/8" (98.4)	4 3/8" (111.1)	4 7/8" (123.8)	-	-	-
1" (25)	2 15/16" (74.6)	4 3/16" (106.4)	4 11/16" (119.1)	5 1/16" (128.6)	-	-	-
1 1/4" (32)	3 1/8" (79.4)	4 3/16" (106.4)	4 5/8" (117.5)	5 1/8" (130.2)	-	-	-
1 1/2" (40)	3 1/4" (82.5)	4 3/8" (111.1)	4 7/8" (123.8)	5 5/16" (134.9)	5 3/4" (146.0)	-	-
2" (50)	3 9/16" (90.5)	4 11/16" (119.1)	5 1/16" (128.6)	5 5/8" (142.9)	6 1/16" (154.0)	-	-
2 1/2" (65)	3 13/16" (96.8)	4 7/8" (123.8)	5 5/16" (134.9)	6" (152.4)	6 3/8" (161.9)	-	-
3" (80)	4 1/8" (104.8)	5 1/16" (128.6)	5 9/16" (141.3)	6 1/8" (155.6)	6 7/16" (163.5)	7" (177.8)	-
3 1/2" (90)	4 3/8" (111.1)	5 5/16" (134.9)	5 13/16" (147.6)	6 1/4" (158.7)	6 11/16" (169.9)	7 1/4" (184.1)	-
4" (100)	4 5/8" (117.5)	5 9/16" (141.3)	6 1/16" (154.0)	6 7/16" (163.5)	6 15/16" (176.2)	7 3/8" (187.3)	-
5" (125)	5" (127.0)	6 1/16" (154.0)	6 7/16" (163.5)	7" (177.8)	7 3/8" (187.3)	7 7/8" (200.0)	8 13/16" (223.8)
6" (150)	5 1/2" (139.7)	6 7/16" (163.5)	6 15/16" (176.2)	7 3/8" (187.3)	7 15/16" (201.6)	8 1/2" (215.9)	9 1/2" (241.3)
8" (200)	6 15/16" (160.3)	7 3/8" (187.3)	7 15/16" (201.6)	8 7/16" (214.3)	8 15/16" (227.0)	-	-



4Dimension compatible fitting

Reference page 168 for general fitting and standard finish specifications.

Pipe Rollers

B219

Pipe Roller Series - 3/4" (20) to 12" (300) Pipe

- Design Load 750 Lbs. (3.33 kN)
- Safety Factor of 5
- Requires field assembly
- When used with B3160 thru B3165 Saddles (see Pipe Hanger Catalog)
- Malleable iron rollers
- Sold in pairs
- Required hardware not included:
2 pcs. 1/2"-13 x 1 1/4" Hex head cap screws
2 pcs. 1/2"-13 Channel nuts
- Reference sizing chart on page 193
- Standard finish: ZN

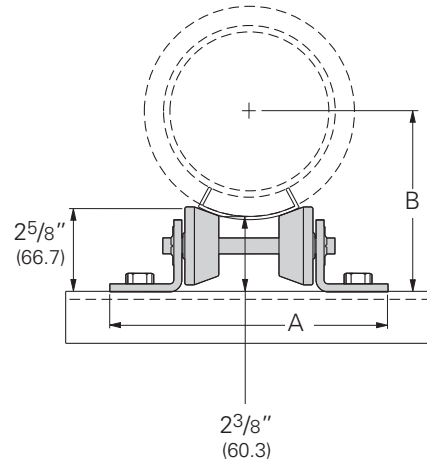
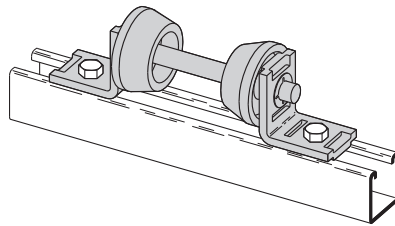

Reference Chart - A Dimension

Part No.	A		Wt./C PR	
	In.	mm	Lbs.	kg
B219	7 1/4"	(184.1)	253	(114.7)
B219-1	8"	(203.2)	258	(117.0)
B219-2	9"	(228.6)	263	(119.3)
B219-3	10"	(254.0)	269	(122.0)
B219-4	10 7/8"	(276.2)	274	(124.8)
B219-5	11 5/8"	(295.3)	279	(126.5)

Reference Chart - B Dimension

Pipe Size	Insulation Thickness in. (mm)						
	0" (0.0)	1" (25.4)	1 1/2" (38.1)	2" (50.8)	2 1/2" (63.5)	3" (76.2)	4" (101.6)
1/2" (15)	2 1/16" (68.3)	-	-	-	-	-	-
3/4" (20)	2 3/16" (71.4)	3 7/8" (98.4)	4 1/2" (114.3)	4 7/8" (123.8)	-	-	-
1" (25)	2 5/16" (74.6)	4 3/16" (106.4)	4 5/8" (117.5)	5 1/16" (128.6)	-	-	-
1 1/4" (32)	3 1/8" (79.4)	4 3/16" (106.4)	4 5/8" (117.5)	5 1/8" (130.2)	-	-	-
1 1/2" (40)	3 1/4" (82.5)	4 7/16" (112.7)	4 7/8" (123.8)	5 1/4" (133.3)	5 3/4" (146.0)	-	-
2" (50)	3 9/16" (90.5)	4 5/8" (117.5)	5 3/16" (131.8)	5 1/2" (139.7)	6 1/16" (154.0)	-	-
2 1/2" (65)	3 3/4" (95.2)	4 7/8" (123.8)	5 1/4" (133.3)	6" (152.4)	6 3/8" (161.9)	-	-
3" (80)	4 1/8" (104.8)	5 1/8" (130.2)	5 9/16" (141.3)	6 1/16" (154.0)	6 7/16" (163.5)	6 15/16" (176.2)	-
3 1/2" (90)	4 1/4" (107.9)	5 1/4" (133.3)	5 13/16" (147.6)	6 1/4" (158.7)	6 11/16" (169.9)	7 1/16" (179.4)	-
4" (100)	4 9/16" (115.9)	5 1/2" (139.7)	6 1/16" (154.0)	6 7/16" (163.5)	6 15/16" (176.2)	7 3/8" (187.3)	-
5" (125)	5 1/16" (128.6)	6 1/16" (154.0)	6 7/16" (163.5)	7" (177.8)	7 3/8" (187.3)	7 7/8" (200.0)	8 15/16" (227.0)
6" (150)	5 7/16" (138.1)	6 7/16" (163.5)	6 15/16" (176.2)	7 3/8" (187.3)	7 7/8" (200.0)	8 15/16" (211.1)	9 9/16" (242.9)
8" (200)	6 3/8" (161.9)	7 7/16" (188.9)	7 15/16" (201.6)	8 3/8" (212.7)	9" (228.6)	-	-
10" (250)	7 5/16" (185.7)	8 3/16" (208.0)	-	-	-	-	-
12" (300)	8 1/4" (209.5)	-	-	-	-	-	-

Reference B219 sizing chart on page 193



4Dimension compatible fitting

Reference page 168 for general fitting and standard finish specifications.

B219 Sizing Chart

Pipe Size	Insulation Thickness in. (mm)						
	0" (0.0)	1" (25.4)	1 1/2" (38.1)	2" (50.8)	2 1/2" (63.5)	3" (76.2)	4" (101.6)
1/2" (15)	B219	–	–	–	–	–	–
3/4" (20)	B219	B219	B219	B219-1	–	–	–
1" (25)	B219	B219	B219-1	B219-1	–	–	–
1 1/4" (32)	B219	B219	B219-1	B219-1	–	–	–
1 1/2" (40)	B219	B219	B219-1	B219-2	B219-2	–	–
2" (50)	B219	B219-1	B219-1	B219-2	B219-2	–	–
2 1/2" (65)	B219	B219-1	B219-2	B219-2	B219-3	–	–
3" (80)	B219	B219-1	B219-2	B219-2	B219-3	B219-3	–
3 1/2" (90)	B219-1	B219-2	B219-2	B219-3	B219-3	B219-4	–
4" (100)	B219-1	B219-2	B219-2	B219-3	B219-3	B219-4	–
5" (125)	B219-1	B219-2	B219-3	B219-3	B219-4	B219-4	B219-5
6" (150)	B219-2	B219-3	B219-3	B219-4	B219-4	B219-5	B219-5
8" (200)	B219-3	B219-4	B219-4	B219-5	B219-5	–	–
10" (250)	B219-4	B219-5	–	–	–	–	–
12" (300)	B219-5	–	–	–	–	–	–

Reference page 168 for general fitting and standard finish specifications.

Pipe Rollers

B379

Pipe Rollers - 6" (150) to 18" (450) Pipe

- Design Load 1500 Lbs. (6.67 kN)
- Safety Factor of 5
- Requires field assembly
- When used with B3160 thru B3165 Saddles (see Pipe Hanger Catalog)
- Malleable iron rollers
- Sold in pairs
- Required hardware not included:
2 pcs. 1/2"-13 x 1 1/4" Hex head cap screws
2 pcs. 1/2"-13 Channel nuts
- Standard finish: ZN
- Wt./C 889 Lbs. (403.2 kg)

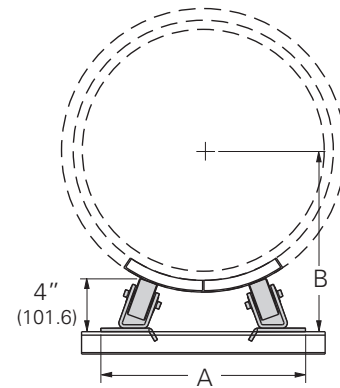
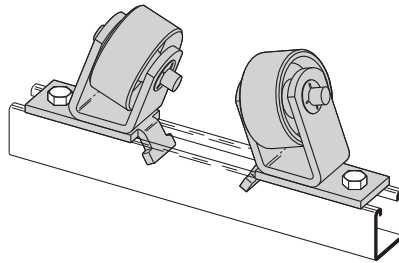

Reference Chart - A Dimension

Pipe Size	Insulation Thickness in. (mm)						
	0" (0.0)	1" (25.4)	1 1/2" (38.1)	2" (50.8)	2 1/2" (63.5)	3" (76.2)	4" (101.6)
6" (150)	9 9/16" (242.9)	10 3/16" (258.8)	10 5/8" (269.9)	11" (279.4)	11 3/8" (288.9)	11 3/4" (298.4)	12 1/2" (317.5)
8" (200)	10 1/4" (260.3)	11 1/16" (281.0)	11 3/8" (288.9)	11 3/4" (298.4)	12 3/16" (309.6)	12 1/2" (317.5)	13 1/4" (336.5)
10" (250)	11" (279.4)	11 3/4" (298.4)	12 1/8" (308.0)	12 1/2" (317.5)	12 13/16" (325.4)	13 1/8" (333.4)	13 7/8" (352.4)
12" (300)	11 11/16" (296.9)	12 9/16" (319.1)	12 7/8" (327.0)	13 1/4" (336.5)	13 9/16" (344.5)	13 7/8" (352.4)	14 5/8" (371.5)
14" (350)	12 1/16" (306.4)	12 7/8" (327.0)	13 3/16" (335.0)	13 9/16" (344.5)	13 7/8" (352.4)	14 1/4" (361.9)	14 7/8" (377.8)
16" (400)	12 3/4" (323.8)	13 1/2" (342.9)	13 7/8" (352.4)	14 13/16" (360.4)	14 1/2" (368.3)	14 7/8" (377.8)	15 1/2" (393.7)
18" (450)	13 1/2" (342.9)	14 1/4" (361.9)	14 5/8" (371.5)	15" (381.0)	15 5/16" (388.9)	15 5/8" (396.9)	16 5/16" (414.3)

Reference Chart - B Dimension

Pipe Size	Insulation Thickness in. (mm)						
	0" (0.0)	1" (25.4)	1 1/2" (38.1)	2" (50.8)	2 1/2" (63.5)	3" (76.2)	4" (101.6)
6" (150)	6 7/8" (174.6)	7 7/8" (200.0)	8 3/8" (212.7)	8 7/8" (225.4)	9 3/8" (238.1)	9 7/8" (250.8)	10 15/16" (277.8)
8" (200)	7 13/16" (198.4)	8 7/8" (225.4)	9 3/8" (238.1)	9 7/8" (250.8)	10 7/16" (265.1)	10 15/16" (277.8)	11 7/8" (301.6)
10" (250)	8 13/16" (223.8)	9 7/8" (250.8)	10 7/16" (265.1)	10 15/16" (277.8)	11 3/8" (288.9)	11 7/8" (301.6)	12 13/16" (325.4)
12" (300)	9 3/4" (247.6)	10 15/16" (277.8)	11 3/8" (288.9)	11 7/8" (301.6)	12 5/16" (312.7)	12 13/16" (325.4)	13 3/4" (349.2)
14" (350)	10 5/16" (261.9)	11 3/8" (288.9)	11 7/8" (301.6)	12 5/16" (312.7)	12 13/16" (325.4)	13 1/4" (336.5)	14 1/4" (361.9)
16" (400)	11 5/16" (287.3)	12 5/16" (312.7)	12 13/16" (325.4)	13 1/4" (336.5)	13 3/4" (349.2)	14 1/4" (361.9)	15 1/8" (384.2)
18" (450)	12 1/4" (311.1)	13 1/4" (336.5)	13 3/4" (349.2)	14 3/16" (360.4)	14 11/16" (373.1)	15 1/8" (384.2)	16 1/16" (408.0)



4Dimension compatible fitting

Reference page 168 for general fitting and standard finish specifications.

B479

Pipe Rollers - 16" (400) to 30" (750) Pipe

- Design Load 2000 Lbs. (8.89 kN)
- Safety Factor of 5
- Requires field assembly
- When used with B3160 thru B3165 Saddles (see Pipe Hanger Catalog)
- Malleable iron rollers
- Sold in pieces
- Required hardware not included:
 - 4 pcs. 1/2"-13 x 1 1/4" Hex head cap screws
 - 4 pcs. 1/2"-13 Channel nuts
- Standard finish: ZN
- Wt./C 889 Lbs. (403.2 kg)

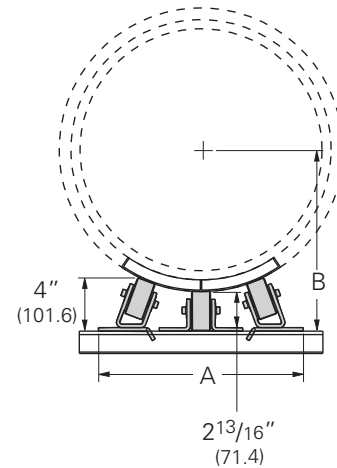
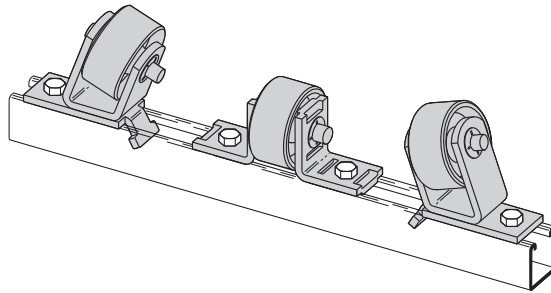

Reference Chart - A Dimension

Pipe Size	Insulation Thickness in. (mm)						
	0" (0.0)	1" (25.4)	1 1/2" (38.1)	2" (50.8)	2 1/2" (63.5)	3" (76.2)	4" (101.6)
16" (400)	15 3/16" (385.8)	15 5/8" (396.9)	15 7/8" (403.2)	16" (406.4)	16 1/4" (412.7)	16 1/2" (419.1)	17" (431.8)
18" (450)	15 1/2" (393.7)	16" (406.4)	16 3/16" (411.2)	16 3/8" (415.9)	16 9/16" (420.7)	16 3/4" (425.4)	17 3/16" (436.6)
20" (500)	16" (406.4)	16 3/8" (415.9)	16 9/16" (420.7)	16 7/8" (428.6)	16 5/16" (430.2)	17 3/16" (436.6)	17 1/2" (444.5)
24" (600)	16 13/16" (427.0)	17 5/16" (439.7)	17 1/2" (444.5)	17 1/2" (444.5)	17 11/16" (449.3)	17 7/8" (454.0)	18 1/8" (460.4)
30" (750)	17 13/16" (452.4)	18 1/4" (463.5)	18 3/8" (466.7)	18 9/16" (471.5)	18 7/8" (476.2)	18 7/8" (479.4)	19 1/4" (488.9)

Reference Chart - B Dimension

Pipe Size	Insulation Thickness in. (mm)						
	0" (0.0)	1" (25.4)	1 1/2" (38.1)	2" (50.8)	2 1/2" (63.5)	3" (76.2)	4" (101.6)
16" (400)	10 13/16" (274.6)	11 15/16" (303.2)	12 3/8" (314.3)	12 15/16" (328.6)	13 3/8" (339.7)	13 15/16" (354.0)	14 15/16" (379.4)
18" (450)	11 7/8" (301.6)	12 15/16" (328.6)	13 7/16" (341.3)	13 15/16" (354.0)	14 7/16" (366.7)	14 15/16" (379.4)	15 15/16" (404.8)
20" (500)	12 3/16" (325.4)	13 15/16" (354.0)	14 7/16" (366.7)	14 7/8" (377.8)	15 7/16" (392.1)	15 7/8" (403.2)	16 15/16" (430.2)
24" (600)	14 13/16" (376.2)	15 7/8" (403.2)	16 3/8" (415.9)	16 7/8" (428.6)	17 3/8" (441.3)	17 7/8" (454.0)	18 7/8" (479.4)
30" (750)	17 13/16" (452.4)	18 7/8" (479.4)	19 3/8" (492.1)	19 7/8" (504.8)	20 3/8" (517.5)	20 5/16" (531.8)	21 15/16" (557.2)



4Dimension compatible fitting

Reference page 168 for general fitting and standard finish specifications.

DURA-BLOK Rooftop Supports



Our DURA-BLOK™ products gives you a versatile and long-term solution for all your roof top support needs. Designed with flexibility in mind, DURA-BLOK is ideal for roof top support applications such as pipe, HVAC, duct, conduit, cable tray, and roof walkways.

Manufactured to provide years of service in harsh, roof top environments, DURA-BLOK is made from 100% recycled rubber, requires no supplemental rubber pads, and will not float or blow away. The 1" (25.4) gap between blocks allow water to flow freely around longer assemblies. For added strength, the DURA-BLOK support channel is through bolted on all sizes. For added visibility, a reflective strip is incorporated on both sides of each DURA-BLOK support.

Beyond product durability, DURA-BLOK helps to dampen vibration, are not sharp or abrasive and requires no roof penetration to maximize existing roof life - and roof structural and environmental integrity. DURA-BLOK is also resistant to freezing and thawing.

Recommended Torque (In channels)

Bolt Size	1/4"-20	5/16"-18	3/8"-16	1/2"-13
ft-lbs	6	11	19	50
Nm	8	15	26	68

Bolt Size	M6x1	M8 x1.25	M10 x 1.5	M12x1.75
Nm	12	17	36	62
ft-Lbs	9	13	27	46

Materials & Finishes

See appropriate fitting pages.
Alternative finishes available upon request.

Metric

Metric dimensions are shown in parentheses.
Unless noted, all metric dimensions are in millimeters.

DURA-BLOK Rooftop Supports

Support Bases Only

- Base only - see chart for height, width and length.
- 100% recycled rubber, UV resistant.
- Load Rating - Ultimate Uniform Load (See Chart Below)*
- DURA-BLOK™ channel support is designed as an economical support for piping systems, cable tray, HVAC equipment and many other applications. The DURA-BLOK is UV resistant and suitable for any type of roofing material or other flat surfaces. Material effectively accepts screw fasteners for securing accessories.



Part No.	Height x Width x Length		Wt./Each		Load Rating	
	In.	mm	Lbs.	kg	Lbs.	kN
DBM	4" x 6" x 4.8"	(101.6 x 152.4 x 121.9)	2.35	(1.07)	200	(0.89)
DBP	4" x 6" x 9.6"	(101.6 x 152.4 x 243.8)	4.48	(2.03)	500	(2.22)

DB Series - Support Bases with Channel

- Base with 1" (25.4mm) tall galvanized channel - see chart for overall height, width and length.
- 100% recycled rubber, UV resistant.
- Load Rating - Ultimate Uniform Load (See Chart Below)*
- DURA-BLOK DB-Series channel support is designed for superior support of piping systems, cable tray, HVAC equipment, walkway systems and many other applications. The DURA-BLOK is UV resistant and suitable for installation on any type of roofing material or other flat surfaces. (For pipe straps/clamps, rollers and roller supports that can be used with these DURA-BLOK supports, see page 202)
- For sloped roofs use B634 adjustable hinge fittings (see page 118).

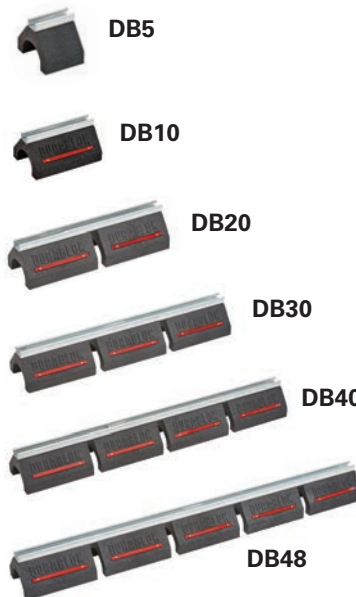

Part No.	Height x Width x Length		Wt./Each		Load Rating	
	In.	mm	Lbs.	kg	Lbs.	kN
DB5	5" x 6" x 4.8"	(127.0 x 152.4 x 121.9)	2.75	(1.25)	200	(0.89)
DB10	5" x 6" x 9.6"	(127.0 x 152.4 x 243.8)	5.28	(2.39)	500	(2.22)
DB20	5" x 6" x 20.2"	(127.0 x 152.4 x 513.1)	10.63	(4.82)	1000	(4.45)
DB30	5" x 6" x 30.8"	(127.0 x 152.4 x 782.3)	15.99	(7.25)	1500	(6.67)
DB40	5" x 6" x 41.4"	(127.0 x 152.4 x 1051.5)	21.34	(9.68)	2000	(8.89)
DB48	5" x 6" x 52.0"	(127.0 x 152.4 x 1320.8)	26.70	(12.40)	2500	(11.12)

DB6 Series - Support Base with B12 Channel

- Base with 12 ga. (2.6mm) galvanized channel 27/16" (61.9mm) tall - see chart for overall height, width and length.
- 100% recycled rubber, UV resistant.
- Load Rating - Ultimate Uniform Load (See Chart Below)*
- DURA-BLOK DB-Series channel support is designed for superior support of piping systems, cable tray, HVAC equipment, walkway systems and many other applications. The DURA-BLOK is UV resistant and suitable for installation on any type of roofing material or other flat surfaces. (For pipe straps/clamps, rollers and roller supports that can be used with these DURA-BLOK supports, see page 202)
- For sloped roofs use B634 adjustable hinge fittings (see page 118).

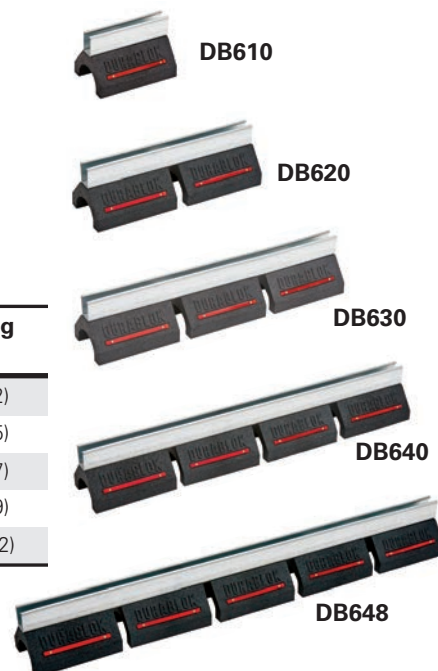

Part No.	Height x Width x Length		Wt./Each		Load Rating	
	In.	mm	Lbs.	kg	Lbs.	kN
DB610	67/16" x 6" x 9.6"	(163.5 x 152.4 x 243.8)	6.36	(2.88)	500	(2.22)
DB620	67/16" x 6" x 20.2"	(163.5 x 152.4 x 513.1)	12.90	(5.85)	1000	(4.45)
DB630	67/16" x 6" x 30.8"	(163.5 x 152.4 x 782.3)	19.45	(8.82)	1500	(6.67)
DB640	67/16" x 6" x 41.4"	(163.5 x 152.4 x 1051.5)	26.00	(11.79)	2000	(8.89)
DB648	67/16" x 6" x 52.0"	(163.5 x 152.4 x 1320.8)	32.55	(14.76)	2500	(11.12)

* **General Note:** Consult roofing manufacturer or engineer for roof load capacity. The weakest point may be the insulation board beneath the rubber membrane.

Reference page 196 for general fitting and standard finish specifications.

DURA-BLOK Rooftop Supports

DB10 SERIES

Support Bases with B22 Channel

- Two (2) bases bridged with 12 ga. (2.6mm) galvanized channel 1⁵/₈" (41.3mm) tall - see chart for overall height, width and length.
- 100% recycled rubber, UV resistant.
- Load Rating: 1000 lbs. (4.45kN) (Uniform Load)*
- DURA-BLOK™ DB10-Series channel support is designed for superior support of piping systems, cable tray, HVAC equipment, walkway systems and many other applications. The DURA-BLOK is UV resistant and suitable for installation on any type of roofing material or other flat surfaces. (For pipe straps/clamps, rollers and roller supports that can be used with these DURA-BLOK supports, see page 202)

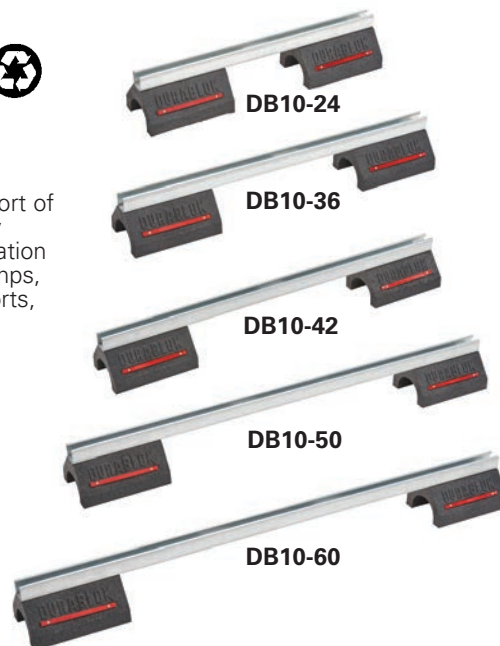

Part No.	Height x Width x Length		Wt./Each	
	In.	mm	Lbs.	kg
DB10-28	5 ⁵ / ₈ " x 6" x 28"	(142.9 x 152.4 x 711.2)	13.16	(5.97)
DB10-36	5 ⁵ / ₈ " x 6" x 36"	(142.9 x 152.4 x 914.4)	14.36	(6.51)
DB10-42	5 ⁵ / ₈ " x 6" x 42"	(142.9 x 152.4 x 1066.8)	15.52	(7.04)
DB10-50	5 ⁵ / ₈ " x 6" x 50"	(142.9 x 152.4 x 1270.0)	16.45	(7.46)
DB10-60	5 ⁵ / ₈ " x 6" x 60"	(142.9 x 152.4 x 1524.0)	17.94	(8.14)

DBM SERIES

Support Base with Riser Rod & Clamp

- Base with 3/8"-16 threaded rod and B3198H clamp - see chart for height, width and length
- 100% recycled rubber, UV resistant.
- Load Rating** 50 lbs. (0.22kN) (Ultimate Load)*
- DURA-BLOK DBM-Series pipe/tubing support is designed for support of single piping systems where elevation adjustment is needed. The DURA-BLOK is UV resistant and suitable for installation on any type of roofing material or other flat surfaces.



DBM-2CT

DBM-1

Part No.	Clamp Part No.†	Block -Height x Width x Length		Height** Min.-Max.		Wt./Each	
		In.	mm	In.	mm	Lbs.	kg
DBM-1/2CT	B3198HCT-1/2	4" x 6" x 4.8"	(101.6 x 152.4 x 121.9)	9.69"-11.19"	(246.1-284.2)	2.75	(1.25)
DBM-3/4CT	B3198HCT-3/4	4" x 6" x 4.8"	(101.6 x 152.4 x 121.9)	9.84"-11.34"	(249.9-2288.0)	2.76	(1.25)
DBM-1CT	B3198HCT-1	4" x 6" x 4.8"	(101.6 x 152.4 x 121.9)	9.95"-11.45"	(252.7-290.8)	2.84	(1.29)
DBM-11/4CT	B3198HCT-11/4	4" x 6" x 4.8"	(101.6 x 152.4 x 121.9)	10.13"-11.63"	(257.3-295.4)	2.95	(1.34)
DBM-11/2CT	B3198HCT-11/2	4" x 6" x 4.8"	(101.6 x 152.4 x 121.9)	10.28"-11.78"	(261.1-299.2)	2.96	(1.34)
DBM-2CT	B3198HCT-2	4" x 6" x 4.8"	(101.6 x 152.4 x 121.9)	10.53"-12.03"	(267.4-305.5)	3.03	(1.37)
DBM-1/2	B3198H-1/2	4" x 6" x 4.8"	(101.6 x 152.4 x 121.9)	9.86"-11.36"	(250.4-288.5)	2.78	(1.26)
DBM-3/4	B3198H-3/4	4" x 6" x 4.8"	(101.6 x 152.4 x 121.9)	10.06"-11.56"	(255.5-293.6)	2.84	(1.29)
DBM-1	B3198H-1	4" x 6" x 4.8"	(101.6 x 152.4 x 121.9)	10.14"-11.64"	(257.5-295.6)	2.86	(1.30)
DBM-11/4	B3198H-11/4	4" x 6" x 4.8"	(101.6 x 152.4 x 121.9)	10.25"-11.75"	(260.3-298.4)	2.93	(1.33)
DBM-11/2	B3198H-11/2	4" x 6" x 4.8"	(101.6 x 152.4 x 121.9)	10.42"-11.92"	(264.6-302.7)	2.99	(1.36)
DBM-2	B3198H-2	4" x 6" x 4.8"	(101.6 x 152.4 x 121.9)	10.66"-12.16"	(270.7-308.8)	3.10	(1.41)

† See Pipe Hanger Catalog for dimensions and specifications. ** From bottom of rubber block to center of pipe/tubing.

* **General Note:** Consult roofing manufacturer or engineer for roof load capacity. The weakest point may be the insulation board beneath the rubber membrane.

Reference page 196 for general fitting and standard finish specifications.

DURA-BLOK Rooftop Supports

DBE Series Support Base with Rod Risers & Channel



- Base with (2) 1/2" electro zinc all threaded rod risers - Top channel is 1" (25.4mm) tall. See chart for adjustable height x wide x length.
- 100% recycled rubber, UV resistant.
- Load Rating* 200 lbs. (0.89kN) (To increase load capacity use load distribution plate CLDP10)
- DURA-BLOK™ DBE-Series channel support is designed as a superior support of piping systems, cable tray, HVAC equipment and many other applications where elevation adjustment is critical. The DURA-BLOK is UV resistant and suitable for installation on any type of roofing material or other flat surfaces. (For pipe straps/clamps, rollers and roller supports that can be used with these DURA-BLOK supports, see page 202)



Part No.	Adjustable Height x Width x Length		Wt./Each	
	In.	mm	Lbs.	kg
DBE10-8	5 1/2-8"	6" x 9.6"	5.68	(2.58)
DBE10-12	5 1/2-12"	6" x 9.6"	5.72	(2.59)
DBE10-16	5 1/2-16"	6" x 9.6"	5.76	(2.61)

DBR Series Support Base with Rod Risers & Pipe Roll



- Base with (2) 1/2" electro zinc all threaded rod risers and a B3114-3 1/2 pipe roll with sockets - base is 4" (101.6mm) high x 6" (152.4mm) wide x 9.6" (243.8mm) long. Overall height is 12" (304.8mm) from bottom of base to contact point on roller.
- Pipe roll & sockets for up to 3 1/2" (90) pipe sizes.
- 100% recycled rubber, UV resistant.
- Load Rating* 200 lbs. (0.89kN) (To increase load capacity use load distribution plate CLDP10)
- DURA-BLOK DBR-Series support is designed to support pipe up to 3 1/2" (90) nominal size where difference in elevation is required and longitudinal movement is expected. The DURA-BLOK is UV resistant and approved for installation on any type of roofing material or other flat surfaces.



Part No.	Adjustable Height x Width x Length		Wt./Each	
	In.	mm	Lbs.	kg
DBR10-12	up to 12"	6" x 9.6"	8.20	(3.72)

CLDP10 Load Distribution Plate

- 11 ga. (3.0mm) steel plate with slots.
- Dimensions: 1 5/8" (41.3mm) wide x 9 1/2" (241.3mm) long.
- DURA-BLOK CLDP10 load bearing stabilizer plate increases load ratings for DBE Series and DBR Series by allowing the load from the threaded rods to be distributed over the length of the base instead of the point load where the rods attach to the base.

Part No.	Thickness x Width x Length		Wt./Each	
	In.	mm	Lbs.	kg
CLDP10	11 Ga.	1 5/8" x 9 1/2"	0.53	(0.24)



Loosen hex nuts and slide plate under the flat washers

Retighten the hex nuts with plate in place



DURA-BLOK Supports

* **General Note:** Consult roofing manufacturer or engineer for roof load capacity. The weakest point may be the insulation board beneath the rubber membrane.

Reference page 196 for general fitting and standard finish specifications.

DURA-BLOK Rooftop Supports

DB_DS Series Support Bases with B22SH Vertical & Horizontal Channel Members

- Product is shipped unassembled.
- Two (2) DB20 bases with 1" (25.4mm) tall galvanized channel -
Bases are 5" (127.0mm) high x 6" (152.4mm) wide x 20.2" (513.1mm) long.
Vertical & Horizontal Riser Channels (SH Style) - 1⁵/₈" (41.3mm) x 1⁵/₈" (41.3mm) x 12 ga. (2.6mm)
Fittings & Hardware - Electro-Plated Steel
- 100% recycled rubber, UV resistant.
- Ultimate Load Rating: 1000 lbs. (4.45kN) (Uniform Load)*
- DURA-BLOK™ DB_DS-Series channel support with risers is designed for superior support of piping systems, cable tray, HVAC equipment, walkway systems and many other applications. The DURA-BLOK is UV resistant and suitable for installation on any type of roofing material or other flat surfaces.
(For pipe straps/clamps, rollers and roller supports that can be used with these DURA-BLOK supports, see page 202)



DB2318DS



DB2918DS

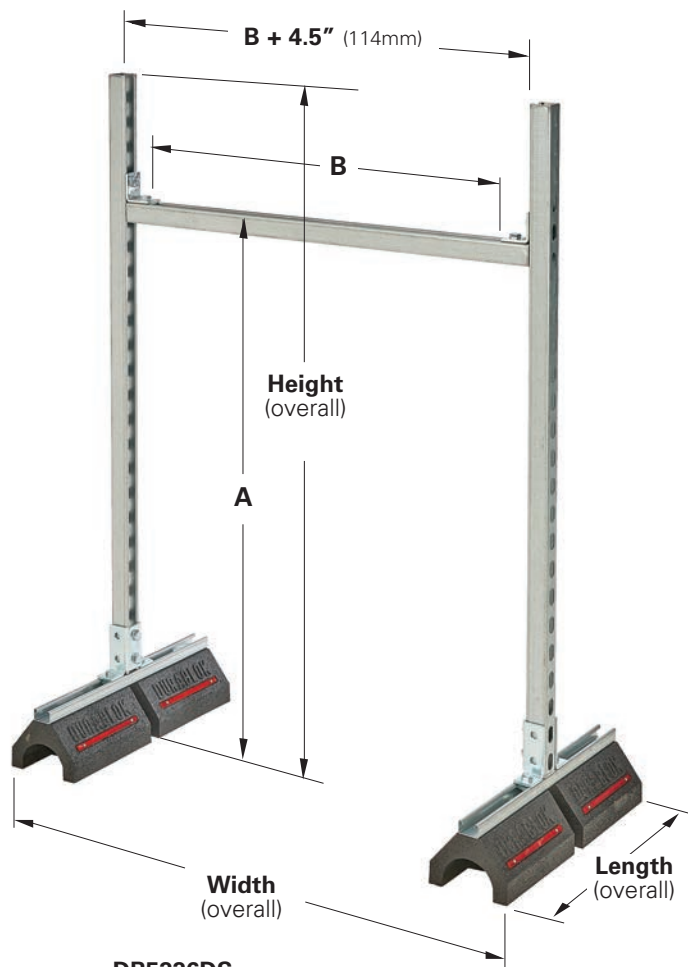

DB5336DS

* **General Note:** Consult roofing manufacturer or engineer for roof load capacity.
The weakest point may be the insulation board beneath the rubber membrane.

Reference page 196 for general fitting and standard finish specifications.

DURA-BLOK Rooftop Supports

DB_DS Series cont.

Part No.	A Min. to Max.		B	
	In.	mm	In.	mm
DB2318DS	10.56"	20.75" (268 to 527)	13 ¹ / ₂ "	(343)
DB2918DS	10.56"	26.75" (268 to 679)	13 ¹ / ₂ "	(343)
DB4118DS	10.56"	38.75" (268 to 984)	13 ¹ / ₂ "	(343)
DB5318DS	10.56"	50.75" (268 to 1289)	13 ¹ / ₂ "	(343)
DB2324DS	10.56"	20.75" (268 to 527)	19 ¹ / ₂ "	(495)
DB2924DS	10.56"	26.75" (268 to 679)	19 ¹ / ₂ "	(495)
DB4124DS	10.56"	38.75" (268 to 984)	19 ¹ / ₂ "	(495)
DB5324DS	10.56"	50.75" (268 to 1289)	19 ¹ / ₂ "	(495)
DB2336DS	10.56"	20.75" (268 to 527)	31 ¹ / ₂ "	(800)
DB2936DS	10.56"	26.75" (268 to 679)	31 ¹ / ₂ "	(800)
DB4136DS	10.56"	38.75" (268 to 984)	31 ¹ / ₂ "	(800)
DB5336DS	10.56"	50.75" (268 to 1289)	31 ¹ / ₂ "	(800)
DB2348DS	10.56"	20.75" (268 to 527)	43 ¹ / ₂ "	(1105)
DB2948DS	10.56"	26.75" (268 to 679)	43 ¹ / ₂ "	(1105)
DB4148DS	10.56"	38.75" (268 to 984)	43 ¹ / ₂ "	(1105)
DB5348DS	10.56"	50.75" (268 to 1289)	43 ¹ / ₂ "	(1105)

Part No.	Height (overall)		Width (overall)		Length (overall)		Wt./Each	
	In.	mm	In.	mm	In.	mm	lbs.	kg
DB2318DS	23"	(584)	25 ⁵ / ₈ "	(651)	20.2"	(513)	33.31	(15.11)
DB2918DS	29"	(736)	25 ⁵ / ₈ "	(651)	20.2"	(513)	35.00	(15.88)
DB4118DS	41"	(1041)	25 ⁵ / ₈ "	(651)	20.2"	(513)	38.40	(17.42)
DB5318DS	53"	(1346)	25 ⁵ / ₈ "	(651)	20.2"	(513)	41.80	(18.96)
DB2324DS	23"	(584)	31 ⁵ / ₈ "	(803)	20.2"	(513)	34.15	(15.49)
DB2924DS	29"	(736)	31 ⁵ / ₈ "	(803)	20.2"	(513)	35.84	(16.26)
DB4124DS	41"	(1041)	31 ⁵ / ₈ "	(803)	20.2"	(513)	39.25	(17.80)
DB5324DS	53"	(1346)	31 ⁵ / ₈ "	(803)	20.2"	(513)	42.65	(19.34)
DB2336DS	23"	(584)	43 ⁵ / ₈ "	(1108)	20.2"	(513)	35.84	(16.26)
DB2936DS	29"	(736)	43 ⁵ / ₈ "	(1108)	20.2"	(513)	37.56	(17.03)
DB4136DS	41"	(1041)	43 ⁵ / ₈ "	(1108)	20.2"	(513)	40.95	(18.57)
DB5336DS	53"	(1346)	43 ⁵ / ₈ "	(1108)	20.2"	(513)	44.34	(20.11)
DB2348DS	23"	(584)	55 ⁵ / ₈ "	(1415)	20.2"	(513)	37.55	(17.03)
DB2948DS	29"	(736)	55 ⁵ / ₈ "	(1415)	20.2"	(513)	39.25	(17.80)
DB4148DS	41"	(1041)	55 ⁵ / ₈ "	(1415)	20.2"	(513)	42.65	(19.34)
DB5348DS	53"	(1346)	55 ⁵ / ₈ "	(1415)	20.2"	(513)	46.03	(20.88)

A = Adjustable height from bottom of DURA-BLOK™ to top of horizontal channel.
 B = Space between fittings that support horizontal channel.
 Height (overall) = Distance from bottom of DURA-BLOK to top of upright channel.
 Width (overall) = Distance from outside-to-outside of DURA-BLOK supports.
 Length (overall) = Distance from end-to-end of DURA-BLOK supports.

Reference page 196 for general fitting and standard finish specifications.

DURA-BLOK Rooftop Supports

DBR Series Support Bases with Channel & Pipe Roller

- Base with 1" (25.4mm) tall galvanized channel - see chart for overall height, width and length.
- 100% recycled rubber, UV resistant.
- Load Rating: (See Chart Below)*
- DURA-BLOK™ DBR-Series support is designed to support pipe where longitudinal movement is expected. The DURA-BLOK is UV resistant and approved for installation on any type of roofing material or other flat surfaces.

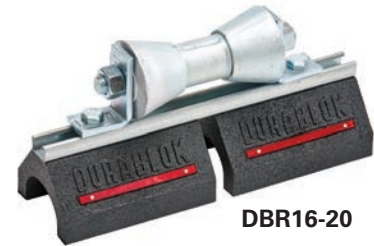

Part No.	Roller Part No.†	Block & Channel -Height x Width x Length		Height**		Wt./Each		Load Rating	
		In.	mm	In.	mm	Lbs.	kg	Lbs.	kN
DBR2-3¹/₂	B3126-2 to 3 ¹ / ₂	5" x 6" x 9.6"	(127.0 x 152.4 x 243.8)	7.09"	(180)	5.28	(2.39)	500	(2.22)
DBR4-6	B3126-4 to 6	5" x 6" x 9.6"	(127.0 x 152.4 x 243.8)	7.09"	(180)	10.63	(4.82)	500	(2.22)
DBR8-10	B3126-8-10	5" x 6" x 20.2"	(127.0 x 152.4 x 513.1)	8.34"	(212)	15.99	(7.25)	1000	(4.45)
DBR12-14	B3126-12-14	5" x 6" x 20.2"	(127.0 x 152.4 x 513.1)	9.38"	(238)	21.34	(9.68)	1000	(4.45)
DBR16-20	B3126-16-20	5" x 6" x 20.2"	(127.0 x 152.4 x 513.1)	9.78"	(248)	26.70	(12.11)	1000	(4.45)

† See Pipe Hanger Catalog for dimensions and specifications. ** From bottom of rubber block to bottom of pipe/tubing.

Compatible Components Available to make DURA-BLOK bases more versatile

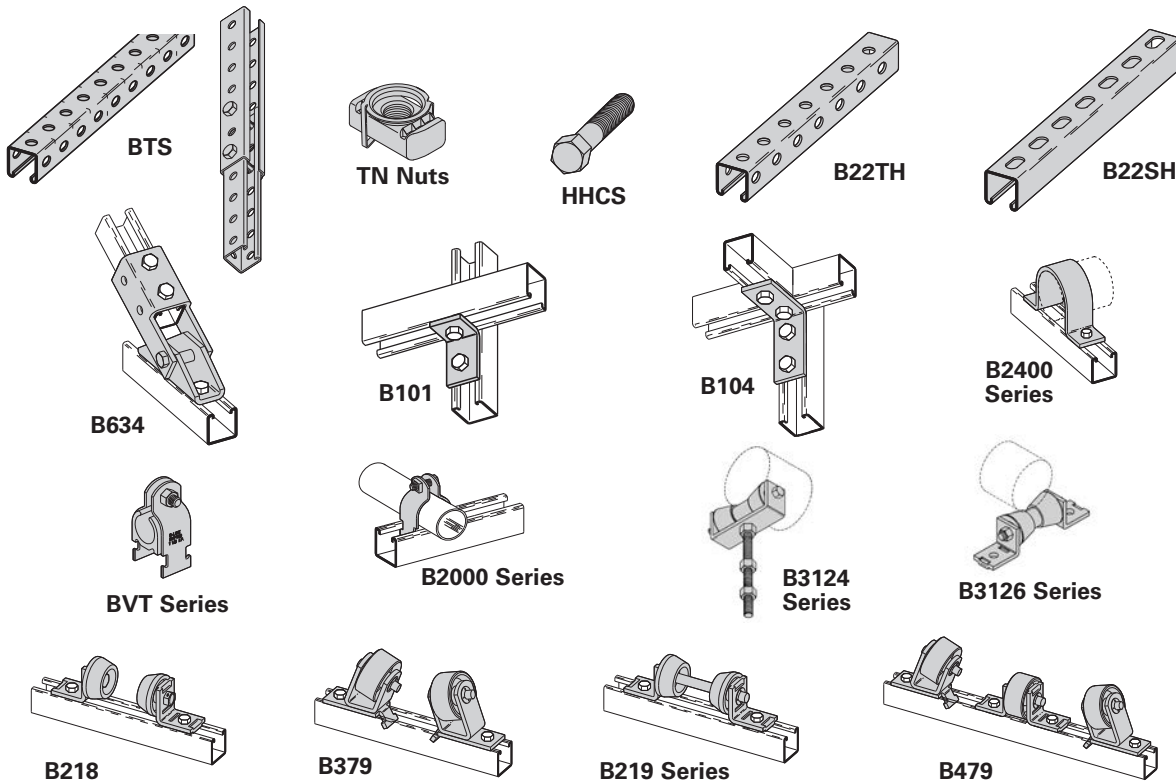

Above rollers can be mounted on DB Series, DB6 Series, and DB10 Series units.

Reference page 196 for general fitting and standard finish specifications.

DURA-BLOK Rooftop Supports

Rooftop Applications



DURA-BLOK Supports

DURA-BLOK Rooftop Supports

GRATEWALK™ Rooftop Walkway with Integrated DURA-BLOK™ Supports

B-Line series GRATEWALK™ Rooftop Walkways with DURA-BLOK™ supports provide the optimal solution to extend the life of your roof, while providing a safe pathway to roof mounted support equipment.



Features & Benefits of the GRATEWALK Rooftop Walkway

- Available with slip resistant GRATE-LOCK™, helping provide a safe walkway for foot traffic on the roof.
- Easy to install, elevated design, creates an identifiable path for foot traffic helping prevent wear and tear to the roof surface.
- The cross-over design offers safe passage over existing cabling, piping, cable tray or any other interference on the rooftop.
- The self cleaning pattern allows water and dirt to easily flow through, helping make the grating an ideal walkway in all weather conditions.
- Handrail options are available
- Integrated with 100% post-consumer recycled rubber supporting LEED credit qualification.
- Provide solid support for the walkway that stays in place and replaces the need for separate rubber roof mounting pads which tend to float away.

GRATEWALK™ Rooftop Walkway with Integrated DURA-BLOK™ Supports

The GRATEWALK™ Rooftop Walkway with Integrated DURA-BLOK™ Supports* is available in a variety of configurations.

- Straight sections for long straight stretches of pathway
- Cross-over options to install over the existing cable trays, piping, and more
- Stairways over the top of existing equipment or leading up to existing equipment
- Handrail options available for additional walkway safety and support
- Platforms to provide access to rooftop mounted equipment
- Accessories available to support unique requirements

* All Items are shipped individually for field assembly.



Engineering Design Service

- Take-off and estimating
- Specification review and development
- Alternative layout designs
- Technical consultation
- Submittal drawing packages (see Figure A) including assembly instructions

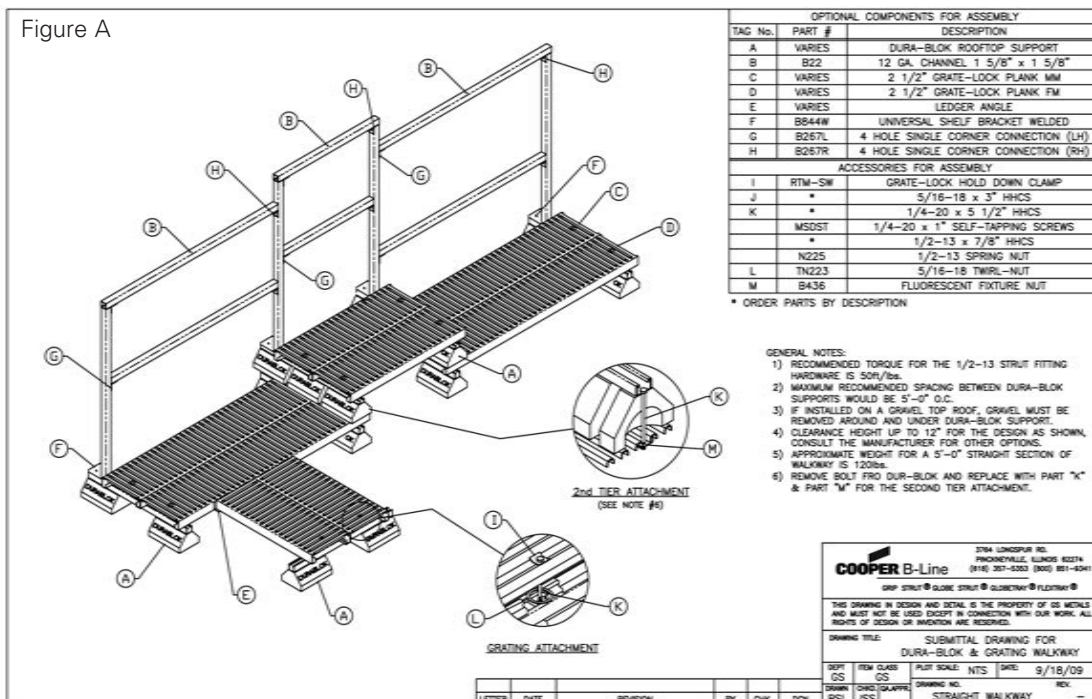

Electrical Accessories



A complete system of top quality, time saving products, designed for surface metal raceways, lighting and cable supports. Innovative designs offer many installation advantages. The surface raceways are U.L. listed and meet the requirements of the National Electrical Code, Article 384.

Surface Raceways

Our channel provides structural support in addition to a raceway system.

For U.L. wire fill see chart on page 278-279.

Cable Supports

A full range of clamps and saddles are offered in porcelain and thermoplastic elastomer. Our Insulclamp™ cable clamps and porcelain saddles are furnished complete with steel clamps (electro-plated) and Everdur hardware where required.

Materials & Finishes*

Steel products are made from low carbon steel strips or plates. Porcelain saddles and clamps are made by dry process and white glazed (porcelain dielectric strength is 50 volts per mil).

*Unless otherwise noted.

Finish Code	Finish	Specification
PLN	Plain	ASTM A1011 33,000 PSI min. yield
ZN	Electro-Plated Zinc	ASTM B633 SC3 Type III
GRN	DURA GREEN™	
GALV	Pre-Galvanized	ASTM A653
YZN	Yellow Zinc Chromate	ASTM B633 SC3 Type II

Design Load

Design load data published includes a Safety Factor of 3.0 (Safety Factor = Ratio of ultimate load to the design load).

U.L. listed raceway channels:

B11, B11KO6	B32, B32KO6
B12, B12KO6	B42, B42KO6
B22, B22KO6	B52, B52KO6
B24, B24KO6	B54, B54KO6
B26, B26KO6	B56, B56KO6

U.L. File No. E29637

In all cases, the snap-in closure strip is required to complete raceway enclosure.

Metric

Metric dimensions are shown in parentheses. Unless noted, all metric dimensions are in millimeters.

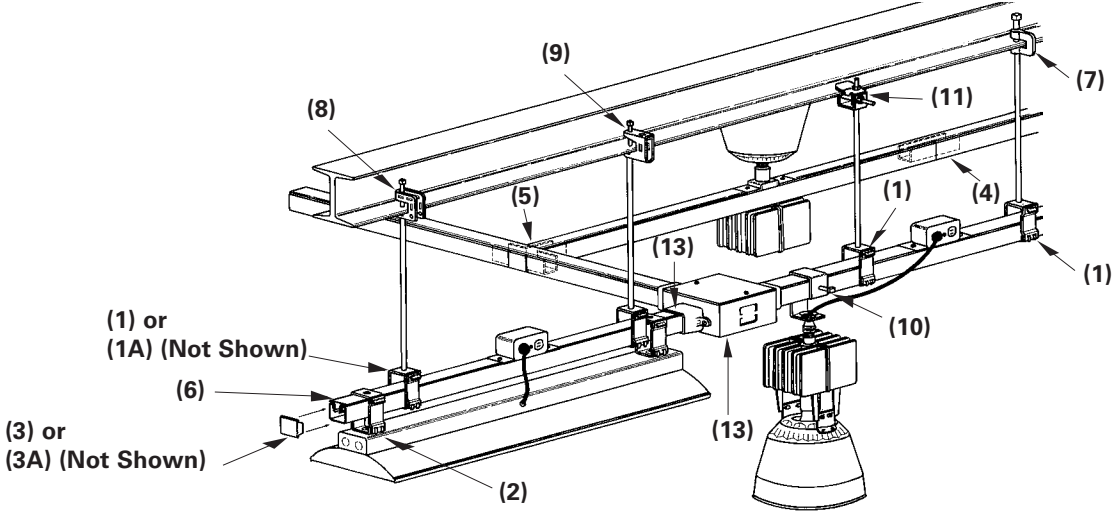

Selection Chart

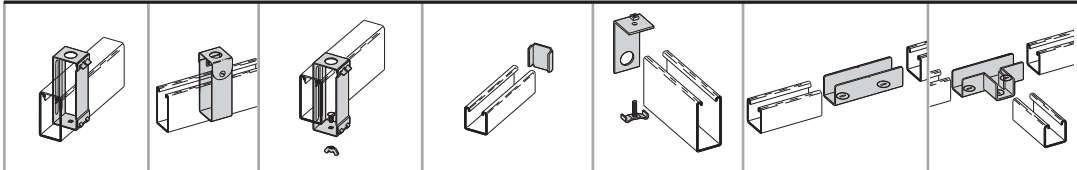
Channel Number	Depth in. mm							
		1 Channel Hanger	1A Channel Hanger	2 Fixture Hanger	3 End Cap	3A Connection End Cap	4 Internal Straight Splice	5 Internal Tee Splice
B22A	3 ¹ / ₄ " (82.5)	B616-22A*	B241S*	B616S-22A*	B205 or B285	B392-22**	B766-22 (2) B285	B768-22 (2)
B11	3 ¹ / ₄ " (82.5)	B616-22A*	B241S*	B616S-22A*	B222	B392-11**	B766-11	B768-11
B12	2 ⁷ / ₁₆ " (61.9)	B616-22A*	B241S*	B616S-22A*	B221	B392-12**	B766-12	B768-12
B22 B24	1 ⁵ / ₈ " (41.3)	B616*	B216S*	B616S* B616TG*	B205 or B285 B223 or B286	B392-22**	B766-22	B768-22
B32	1 ³ / ₈ " (34.9)	B616*	B216S*	B616S* B616TG*	B206	B392-32**	B766-32	B768-32
B42	1" (25.4)	B616*	B215S*	B616S* B616TG*	B203	—	B766-42	B768-42
B52 B54	1 ³ / ₁₆ " (20.6)	B616*	B215S*	B616S* B616TG*	B220 or B283 B204 or B284	—	B766-52	B768-52

*Specify Hanger Rod or Conduit Size.

**Specify Conduit Size

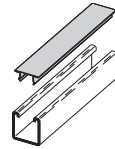
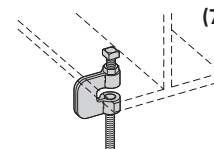
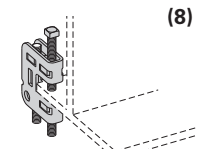
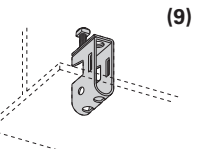
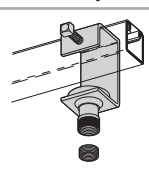
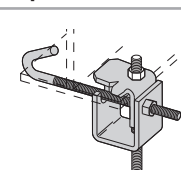
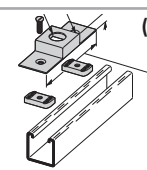
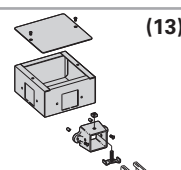
<p>B217-20</p>  <p>Snap-in Closure Strip</p>	<p>B351L</p>  <p>Beam Clamp</p>	<p>B755</p>  <p>Beam Clamp</p>	<p>B751</p>  <p>Beam Clamp</p>
<p>B465</p>  <p>H.I.D. Fixture Hanger</p>	<p>B750</p>  <p>Beam Clamp</p>	<p>B447 B447A</p>  <p>Conduit Connection Plate</p>	<p>B719</p>  <p>B718 Series Junction Box</p>

Reference page 206 for general fitting and standard finish specifications. U.L. Wire Fill Chart on pages 272 - 273.

Fluorescent Fixture Hangers

B616-9/16 Channel Hanger

- Design Load 250 Lbs. (1.11 kN)
- Safety Factor of 3
- Maximum design load 50 Lbs. (.22 kN) when used as a fixture support
- Includes:
2 pcs. $\frac{3}{8}$ " Flat washers for use with $\frac{3}{8}$ " ATR
- Material: 16 gauge (1.5)
- Standard finish: ZN
- Wt./C 25 Lbs. (11.3 kg)

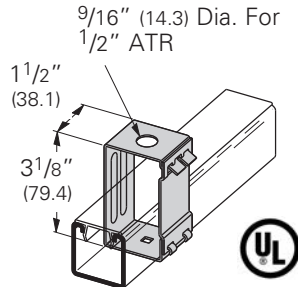

B616-7/8 Channel Hanger

- Design Load 250 Lbs. (1.11 kN)
- Safety Factor of 3
- Maximum design load 50 Lbs. (.22 kN) when used as a fixture support
- Material: 16 gauge (1.5)
- Standard finish: ZN
- Wt./C 25 Lbs. (11.3 kg)

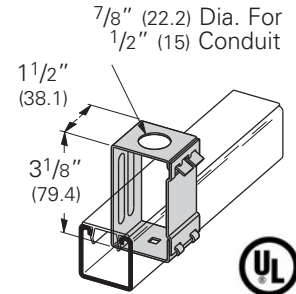

B616S-9/16 Fluorescent Fixture Hanger with Stud

- Design Load 150 Lbs. (.67 kN)
- Safety Factor of 3
- Maximum design load 50 Lbs. (.22 kN) when used as a fixture support
- Allows more than $\frac{1}{2}$ " (12.7) space between channel and fixture
- Includes:
2 pcs. $\frac{3}{8}$ " Flat washers for use with $\frac{3}{8}$ " ATR
- Material: 16 gauge (1.5)
- Standard finish: ZN
- Wt./C 30 Lbs. (13.6 kg)

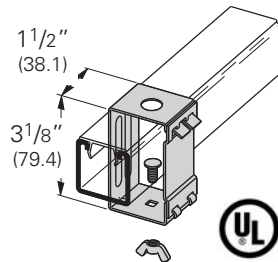

B616S-7/8 Fluorescent Fixture Hanger with Stud

- Design Load 150 Lbs. (.67 kN)
- Safety Factor of 3
- Maximum design load 50 Lbs. (.22 kN) when used as a fixture support
- Allows more than $\frac{1}{2}$ " (12.7) space between channel and fixture
- Standard finish: ZN
- Material: 16 gauge (1.5)
- Wt./C 30 Lbs. (13.6 kg)

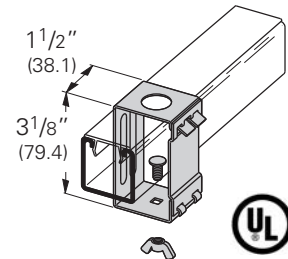

B616-22A-9/16 Channel Hanger

- Design Load 250 Lbs. (1.11 kN)
- Safety Factor of 3
- Maximum design load 50 Lbs. (.22 kN) when used as a fixture support
- Includes:
2 pcs. $\frac{3}{8}$ " Flat washers for use with $\frac{3}{8}$ " ATR
- Material: 14 gauge (1.9)
- Standard finish: ZN
- Wt./C 44 Lbs. (19.9 kg)

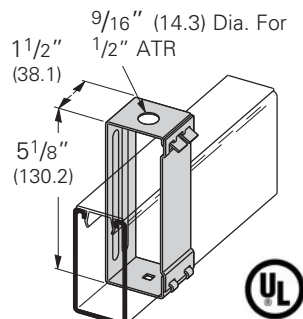

B616-22A-7/8 Channel Hanger

- Design Load 250 Lbs. (1.11 kN)
- Safety Factor of 3
- Maximum design load 50 Lbs. (.22 kN) when used as a fixture support
- Material: 14 gauge (1.9)
- Standard finish: ZN
- Wt./C 44 Lbs. (19.9 kg)

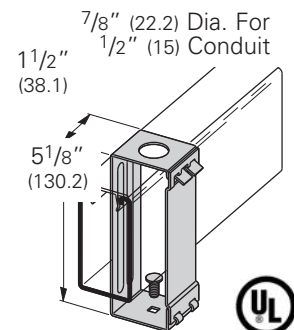

Reference page 206 for general fitting and standard finish specifications. U.L. Wire Fill Chart on pages 272 - 273.

Fluorescent Fixture Hangers

B616S-22A-9/16 Fluorescent Fixture Hanger with Stud

- Design Load 150 Lbs. (.67 kN)
- Safety Factor of 3
- Maximum design load 50 Lbs. (.22 kN) when used as a fixture support
- Includes:
2 pcs. $\frac{3}{8}$ " Flat washers for use with $\frac{3}{8}$ " ATR
- Allows more than $\frac{1}{2}$ " (12.7) space between channel and fixture
- Material: 14 gauge (1.9)
- Standard finish: ZN
- Wt./C 49 Lbs. (22.2 kg)

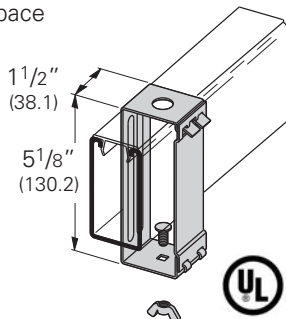

B616S-22A-7/8 Fluorescent Fixture Hanger with Stud

- Design Load 150 Lbs. (.67 kN)
- Safety Factor of 3
- Maximum design load 50 Lbs. (.22 kN) when used as a fixture support
- Allows more than $\frac{1}{2}$ " (12.7) space between channel and fixture
- Material: 14 gauge (1.9)
- Standard finish: ZN
- Wt./C 49 Lbs. (22.2 kg)

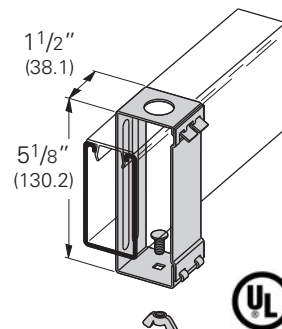

B616TG-9/16 Fluorescent Fixture Hanger for 1/2" (15) Knockout

- Design Load 150 Lbs. (.67 kN)
- Safety Factor of 3
- Maximum design load 50 Lbs. (.22 kN) when used as a fixture support
- Includes:
2 pcs. $\frac{3}{8}$ " Flat washers for use with $\frac{3}{8}$ " ATR
- Design Load 150 Lbs. (.67 kN)
- Allows more than $\frac{1}{2}$ " (12.7) space between channel and fixture
- Material: 16 gauge (1.5)
- Standard finish: ZN
- Wt./C 32 Lbs. (14.5 kg)

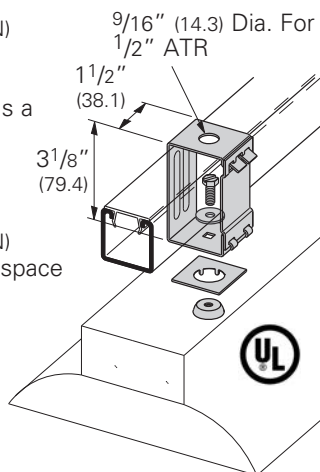

B215S Channel Hanger

- Can be used with $\frac{3}{8}$ " & $\frac{1}{2}$ " threaded rod or $\frac{3}{8}$ " & $\frac{1}{2}$ " conduit
- Design Load 250 Lbs. (1.11 kN)
- Safety Factor of 3
- For use with B42, B52, & B54 channels
- Hardware included:
One (1) $\frac{3}{8}$ " x $1\frac{1}{2}$ " FFW for use with $\frac{3}{8}$ "-16 ATR
One (1) $\frac{1}{2}$ " FW for use with $\frac{1}{2}$ "-13 ATR
One (1) $\frac{5}{8}$ " FW for use with $\frac{3}{8}$ " conduit
- Material: 16 gauge (1.5)
- Standard finish: ZN
- Wt./C 31 Lbs. (14.0 kg)

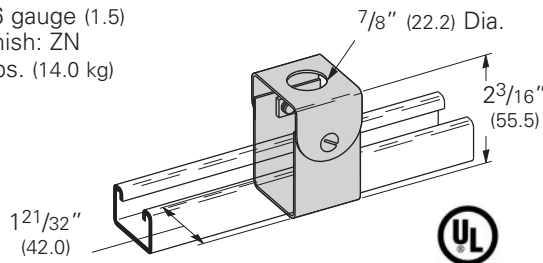

B216S Channel Hanger

- Can be used with $\frac{3}{8}$ " & $\frac{1}{2}$ " threaded rod or $\frac{3}{8}$ " & $\frac{1}{2}$ " conduit
- Design Load 250 Lbs. (1.11 kN)
- Safety Factor of 3
- For use with B22, B24, & B32 channels
- Hardware included:
One (1) $\frac{3}{8}$ " x $1\frac{1}{2}$ " FFW for use with $\frac{3}{8}$ "-16 ATR
One (1) $\frac{1}{2}$ " FW for use with $\frac{1}{2}$ "-13 ATR
One (1) $\frac{5}{8}$ " FW for use with $\frac{3}{8}$ " conduit
- Material: 16 gauge (1.5)
- Standard finish: ZN
- Wt./C 38 Lbs. (17.2 kg)

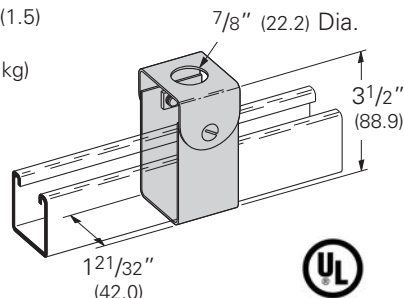

B241S Channel Hanger

- Can be used with $\frac{3}{8}$ " & $\frac{1}{2}$ " threaded rod or $\frac{3}{8}$ " & $\frac{1}{2}$ " conduit
- Design Load 250 Lbs. (1.11 kN)
- Safety Factor of 3
- For use with B11 & B12 channels
- Hardware included:
One (1) $\frac{3}{8}$ " x $1\frac{1}{2}$ " FFW for use with $\frac{3}{8}$ "-16 ATR
One (1) $\frac{1}{2}$ " FW for use with $\frac{1}{2}$ "-13 ATR
One (1) $\frac{5}{8}$ " FW for use with $\frac{3}{8}$ " conduit
- Material: 16 gauge (1.5)
- Standard finish: ZN
- Wt./C 47 Lbs. (21.3 kg)

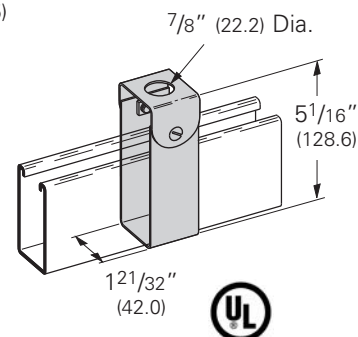

Reference page 206 for general fitting and standard finish specifications. U.L. Wire Fill Chart on pages 272 - 273.

Fluorescent Fixture Hangers

B390S 360° Swivel Channel Connector

- Design Load 250 Lbs. (1.11 kN)
- Safety Factor of 3
- Maximum design load 50 Lbs. (.22 kN) when used as a fixture support
- Swings 15° in 360° plane
- Includes:
 - 2 pcs. SN224-3/4"WO Stud nut
 - 2 pcs. 1/4"-20 Square nut
 - 1 pc. 3/4" (20) to 1/2" (15) Conduit Reducer
- Standard finish: ZN
- Wt./C 71 Lbs. (32.2 kg)

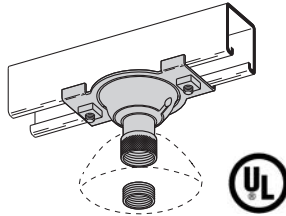

B390BX 360° Swivel Box Connector

- Design Load 250 Lbs. (1.11 kN) for connector fitting only
- Safety Factor of 3
- Design Load 50 Lbs. (.22 kN) when used as illustrated or for use as a fixture support
- Swings 15° in 360° plane
- Includes:
 - 1 pc. 3/4" (20) to 1/2" (15) Conduit reducer
- Fits on 4" box
- Standard finish: ZN
- Wt./C 55 Lbs. (24.9 kg)

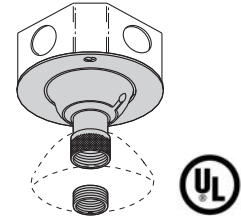

B465 H.I.D. Fixture Hanger

- Design Load 250 Lbs. (1.11 kN)
- Safety Factor of 3
- Swings 15° in 360° plane
- Includes:
 - 1 pc. 3/4" (20) to 1/2" (15) Conduit reducer
- Standard finish: ZN
- Wt./C 95 Lbs. (43.1 kg)

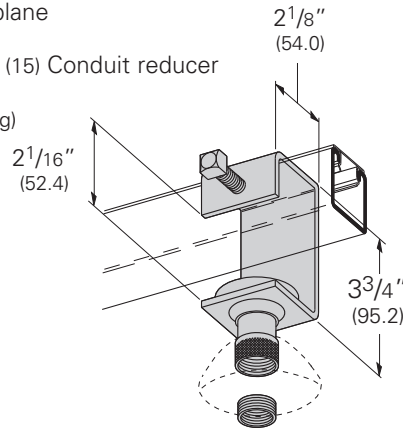

B436 Fluorescent Fixture Nut

- Standard finish: ZN
- Wt./C 2 Lbs. (.9 kg)

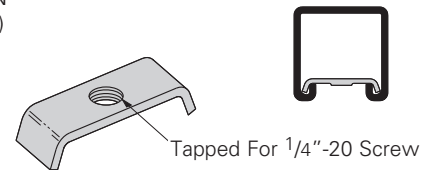

B436S Fluorescent Fixture Stud Nut

- Bolt size: 1/4" x 1 1/4"
- Standard finish: ZN
- Wt./C 4 Lbs. (1.8 kg)
- Design Load 250 Lbs. (1.11 kN)
- Safety Factor of 3

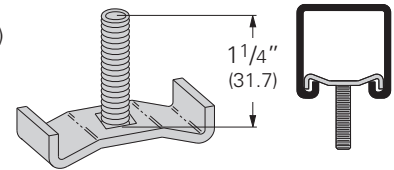

B460 Fluorescent Fixture Hanger

- Hanger is shipped flat and requires field bending as shown
- Allows more than 1/2" (12.7) space between channel and fixture
- Material: 18 gauge (1.2)
- Standard finish: ZN

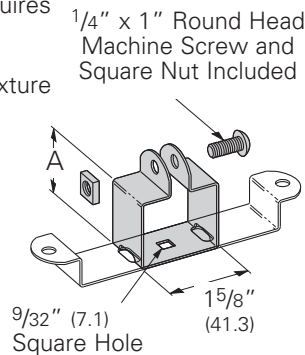

B464 Fluorescent Fixture Hanger

- Hanger is shipped flat and requires field bending as shown
- Allows more than 1/8" (3.2) space between channel and fixture
- Material: 18 gauge (1.2)
- Standard finish: ZN

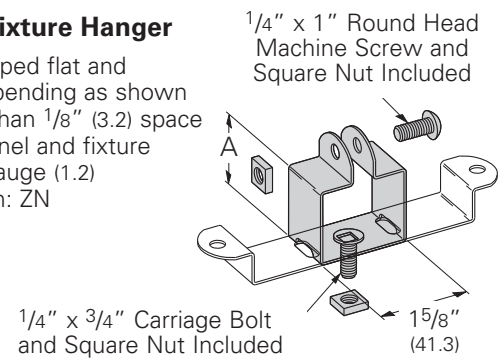

Part No.	For Channel Size	A		Wt./C	
		In.	mm	Lbs.	kg
B460-22	B22, B24, B32	2 1/8"	(57.5)	17	(7.7)
B460-12	B12	2 15/16"	(79.5)	20	(9.1)
B460-11	B11	3 3/4"	(101.6)	23	(10.4)

Part No.	For Channel Size	A		Wt./C	
		In.	mm	Lbs.	kg
B464-32	B32	1 1/2"	(40.6)	17	(7.7)
B464-22	B22, B24	1 3/4"	(47.4)	18	(8.1)
B464-12	B12	2 9/16"	(66.0)	21	(9.5)
B464-11	B11	3 3/8"	(91.4)	24	(10.9)

Reference page 206 for general fitting and standard finish specifications. U.L. Wire Fill Chart on pages 272 - 273.

B217-20 Snap Closure Strip for All 1⁵/₈" (41.3) Wide Channels

- Refer to Raceway Fill Chart pages 278-279
- Material: 20 gauge (.9)
- Standard finishes: GRN, GALV, YZN
- Standard length: 120" (3.05m)
- Wt./CFT 36 Lbs. (16.3 kg)

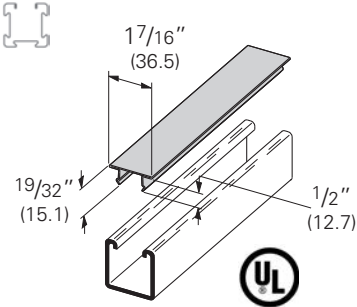

B217P Plastic Snap Closure Strip for All 1⁵/₈" (41.3) Wide Channels

- Refer to Raceway Fill Chart pages 278-279
- Standard finishes: Green (GRN) or Gray (GRY) Plastic
- Standard length: 120" (3.05m)
- Wt./CFT 9.2 Lbs. (4.2 kg)

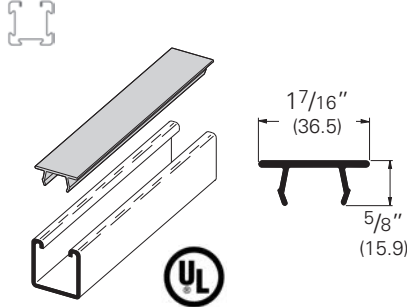

B217-24 Snap Closure Strip for All 1⁵/₈" (41.3) Wide Channels

- Refer to Raceway Fill Chart pages 278-279
- For use with 7 or fewer conductors no larger than #12 AWG
- Material: 24 gauge (.6)
- Standard finishes: GRN, GALV, YZN
- Standard length: 120" (3.05m)
- Wt./CFT 28 Lbs. (12.7 kg)

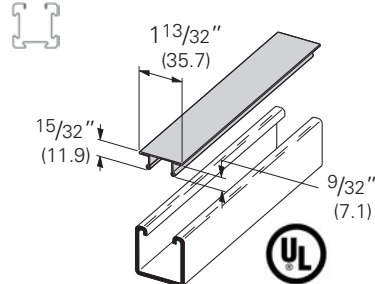

B516 Snap-In Outlet Box

- Provided with #10-32 tapped hole for grounding strap
- Duplex cover plate included
- Receptacle not furnished
- Requires ground wire installation for use with UL listed channel raceway system
- Standard finish: GALV
- Wt./C 72 Lbs. (32.6 kg)

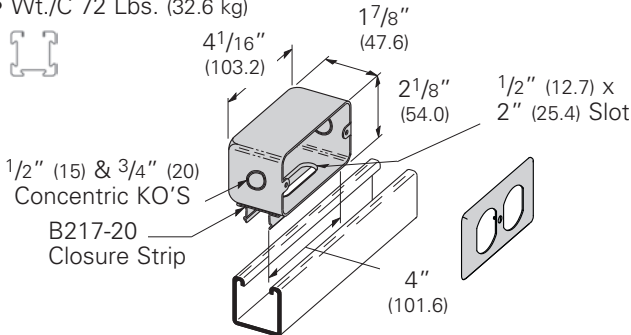

B516S Outlet Box

- Duplex cover plate included
- Receptacle not furnished
- Includes:
 - 2 pcs. 1/4"-20 Flat head machine screws
 - 2 pcs. N224WO Channel nuts
- Standard finish: GALV
- Wt./C 98 Lbs. (44.4 kg)

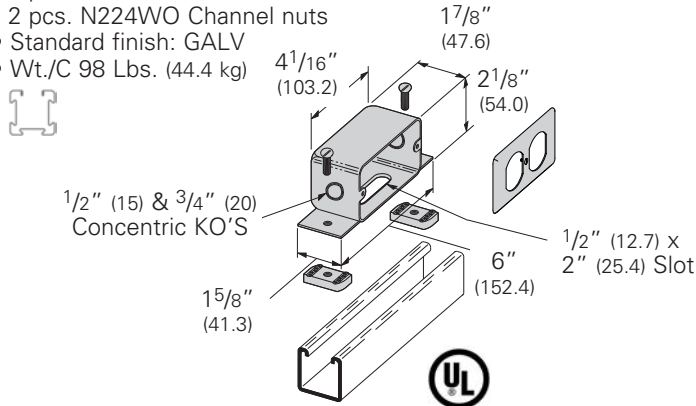

B203 thru B206 B220 thru B223 X Type End Caps

- Material: 12 gauge (2.6)
- Standard finishes: ZN, GRN, HDG, SS4

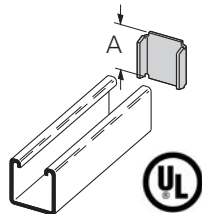

Part No.	Use With	A		Wt./C	
		In.	mm	Lbs.	kg
B203	B42	1.015"	(25.8)	6	(2.7)
B204	B54	.827"	(21.0)	5	(2.2)
B205	B22	1.640"	(41.6)	10	(4.5)
B206	B32	1.390"	(35.3)	8	(3.6)
B220	B52	.827"	(21.0)	4	(1.8)
B221	B12	2.452"	(62.3)	15	(6.8)
B222	B11	3.265"	(82.9)	20	(9.1)
B223	B24	1.640"	(41.6)	10	(4.5)

B283 thru B286 End Caps

- Material: 12 gauge (2.6)
- Standard finishes: ZN, GRN

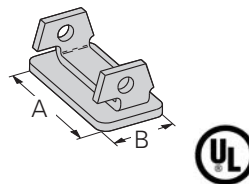

Part No.	Use With	A		B		Wt./C Lbs. kg
		In.	mm	In.	mm	
B283	B52	1 ¹⁹ / ₃₂ "	(40.5)	2 ⁵ / ₃₂ "	(19.8)	6 (2.7)
B284	B54	1 ¹⁹ / ₃₂ "	(40.5)	2 ⁵ / ₃₂ "	(19.8)	6 (2.7)
B285	B22	1 ¹⁹ / ₃₂ "	(40.5)	1 ¹⁹ / ₃₂ "	(40.5)	13 (5.9)
B286	B24	1 ¹⁹ / ₃₂ "	(40.5)	1 ¹⁹ / ₃₂ "	(40.5)	14 (6.3)

4Dimension compatible fitting

Reference page 206 for general fitting and standard finish specifications. U.L. Wire Fill Chart on pages 272 - 273.

Electrical Accessories

B447 Conduit Connection Plate for 1/2" (15) Conduit

- Includes:
 - 2 pcs. 1/4"-20 Flat head machine screws
 - 2 pcs. N224WO Channel nuts
- Material: 16 gauge (1.5)
- Standard finish: ZN
- Wt./C 35 Lbs. (15.9 kg)

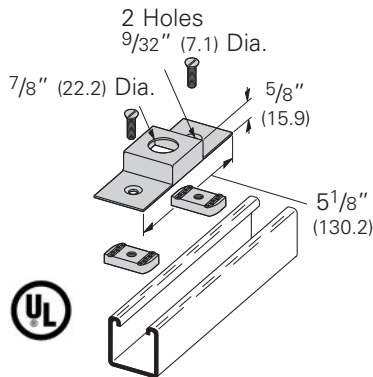

B447A Conduit Connection Plate for 3/4" (20) Conduit

- Includes:
 - 2 pcs. 1/4"-20 Flat head machine screws
 - 2 pcs. N224WO Channel nuts
- Material: 16 gauge (1.5)
- Standard finish: ZN
- Wt./C 35 Lbs. (15.9 kg)

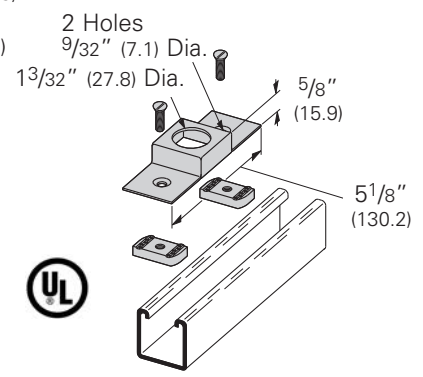

B392-32 Series Connection End Cap

- Includes:
 - 1 pc. 1/4"-20 Square nut
 - 1 pc. B436S Fixture stud nut
- Material: 11 gauge (3.0)
- Standard finish: ZN

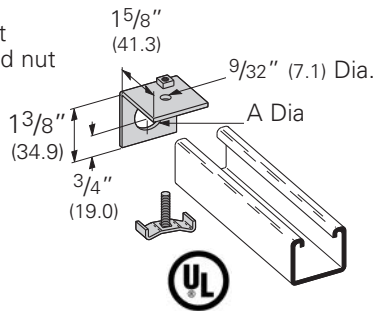

Part No.	A		Conduit Size		Wt./C	
	In.	mm	In.	mm	Lbs.	kg
B392-32-1/2	7/8"	(22.2)	1/2"	(15)	20	(9.1)
B392-32-3/4	1 1/16"	(27.0)	3/4"	(20)	19	(8.6)

B392-22 Series Connection End Cap

- Includes:
 - 1 pc. 1/4"-20 Square nut
 - 1 pc. B436S Fixture stud nut
- Material: 11 gauge (3.0)
- Standard finish: ZN

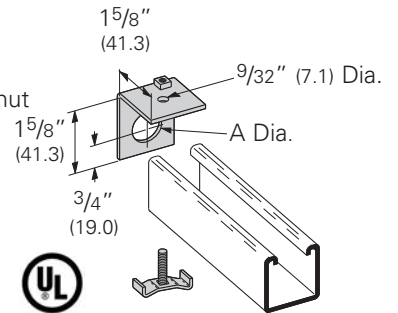

Part No.	A		Conduit Size		Wt./C	
	In.	mm	In.	mm	Lbs.	kg
B392-22-1/2	7/8"	(22.2)	1/2"	(15)	21	(9.5)
B392-22-3/4	1 1/16"	(27.0)	3/4"	(20)	20	(9.1)
B392-22-1	1" Pipe Thread		1"	(25)	17	(7.7)

B392-12 Series Connection End Cap

- Includes:
 - 1 pc. 1/4"-20 Square nut
 - 1 pc. B436S Fixture stud nut
- Material: 11 gauge (3.0)
- Standard finish: ZN

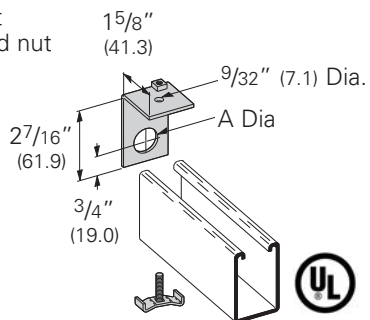

Part No.	A		Conduit Size		Wt./C	
	In.	mm	In.	mm	Lbs.	kg
B392-12-1/2	7/8"	(22.2)	1/2"	(15)	27	(12.2)
B392-12-3/4	1 1/16"	(27.0)	3/4"	(20)	26	(11.8)
B392-12-1	1" Pipe Thread		1"	(25)	23	(10.4)

B392-11 Series Connection End Cap

- Includes:
 - 1 pc. 1/4"-20 Square nut
 - 1 pc. B436S Fixture stud nut
- Material: 11 gauge (3.0)
- Standard finish: ZN

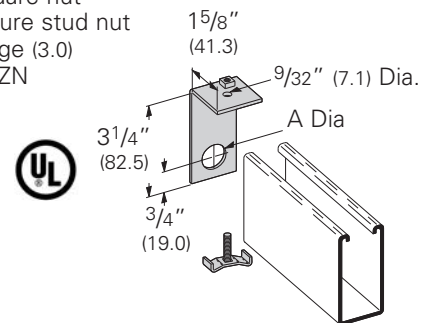

Part No.	A		Conduit Size		Wt./C	
	In.	mm	In.	mm	Lbs.	kg
B392-11-1/2	7/8"	(22.2)	1/2"	(15)	36	(16.3)
B392-11-3/4	1 1/16"	(27.0)	3/4"	(20)	33	(14.9)
B392-11-1	1" Pipe Thread		1"	(25)	32	(14.5)

Reference page 206 for general fitting and standard finish specifications. U.L. Wire Fill Chart on pages 272 - 273.

B718 Universal Junction Bob

- Assemble B719 Hubs into B718 square knockouts
- Designed for use with B22 & B24 channel
- B718 Includes:
 - 1 pc. Junction box only
 - 1 pc. Cover only
 - 2 pcs. #10-20 Round head machine screws
- Standard finish: ZN
- Wt./C 180 Lbs. (81.6 kg)

Part No.	Includes	Wt./C	
		Lbs.	kg
B718-1	1 B718 & 1 B719	205	(93.0)
B718-2	1 B718 & 2 B719	230	(104.3)
B718-3	1 B718 & 3 B719	255	(115.6)
B718-4	1 B718 & 4 B719	280	(127.0)

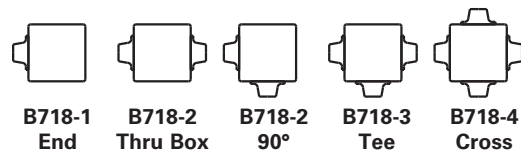

Selection Guide

Box Dimension:
2 1/2" (63.5 Deep x
5 1/8" (130.2) Square

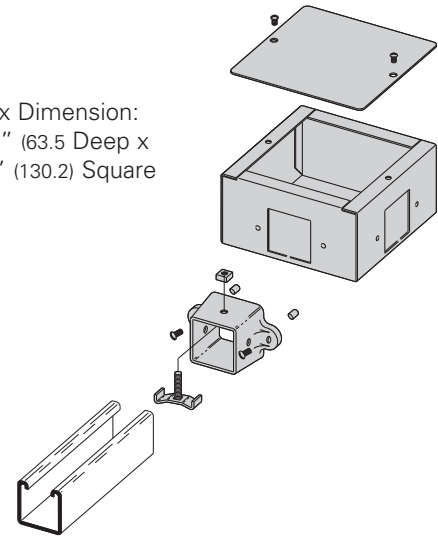

B719AL Universal Junction Box Hub

- B719AL Includes:
 - 1 pc. B719AL Hub only
 - 1 pc. B436S Fixture stud nut
 - 1 pc. 1/4"-20 Square nut
 - 2 pcs. #10-24 Self tapping ncrews
 - 2 pcs. Rubber caps
- Material: Aluminum
- Wt./C 25 Lbs. (11.3 kg)

B518-1 thru B518-4 Universal Junction Box & Hubs

- Channel connection kits as shown in the chart above
- Includes:
 - 1 pc. Junction box with screws
 - 1 pc. Box cover
- Standard finish: ZN

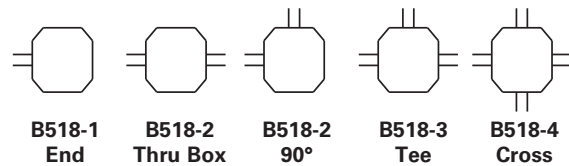

Selection Guide

Part No.	Channel Connection Kits Included	Wt./C	
		Lbs.	kg
B518-1	1	106	(48.1)
B518-2	2	137	(62.1)
B518-3	3	162	(78.5)
B518-4	4	192	(87.1)

Channel Connection Kit

- For use with B22 & B24 channels.
- Box Dimension: Standard 4" octagon box
- Includes:
 - 1 pc. B392-22-3/4 End connection (See page 212)
 - 1 pc. 3/4" (20) Insulated chase nipple
 - 1 pc. 3/4" (20) Lock nut
- Standard finish: ZN

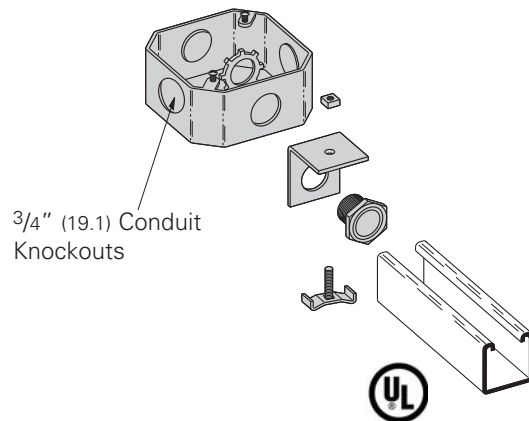

Reference page 206 for general fitting and standard finish specifications. U.L. Wire Fill Chart on pages 272 - 273.

Strut Joiners

B766 Series Straight Strut Joiner

- Includes: 2 Cam screws
- Material: 12 gauge (2.6)
- Standard finish: ZN

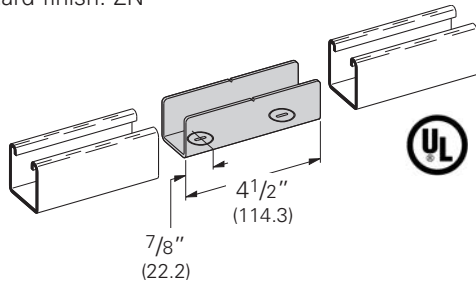

Part No.	For Channel Size	Wt./C	
		Lbs.	kg
B766-11	B11	94	(42.6)
B766-12	B12	72	(32.6)
B766-22 *	B22 & B24	50	(22.7)
B766-32	B32	44	(19.9)
B766-42	B42	34	(15.4)
B766-52	B52 & B54	28	(12.7)

* Cast aluminum parts

B767 Series 90° Elbow Strut Joiner

- Includes: 2 Cam screws
- Material: 12 gauge (2.6)
- Standard finish: ZN

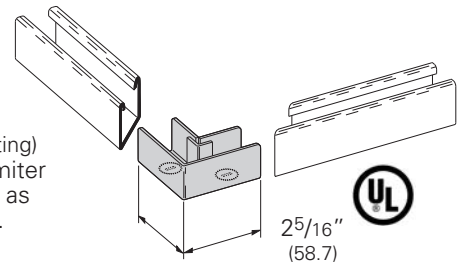

Note: B767-22 (Cast Aluminum Fitting) does not require miter cutting of channel as shown in drawing.

Part No.	For Channel Size	Wt./C	
		Lbs.	kg
B767-11	B11	74	(33.5)
B767-12	B12	56	(25.4)
B767-22 *	B22 & B24	39	(17.7)
B767-32	B32	34	(15.4)
B767-42	B42	27	(12.2)
B767-52	B52 & B54	23	(10.4)

* Cast aluminum parts

B768 Series Tee Strut Joiner

- Includes: 3 Cam screws
- Patented
- Material: 12 gauge (2.6)
- Standard finish: ZN

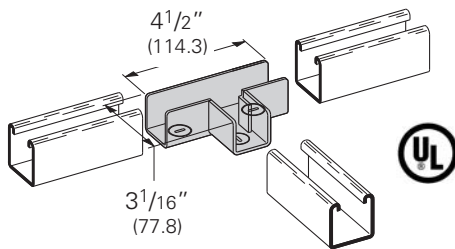

Part No.	For Channel Size	Wt./C	
		Lbs.	kg
B768-11	B11	142	(64.4)
B768-12	B12	112	(50.8)
B768-22 *	B22 & B24	79	(35.8)
B768-32	B32	72	(32.6)
B768-42	B42	62	(28.1)
B768-52	B52 & B54	57	(25.8)

* Cast aluminum parts

B769 Series Cross Strut Joiner

- Includes: 4 Cam screws
- Patented
- Material: 12 gauge (2.6)
- Standard finish: ZN

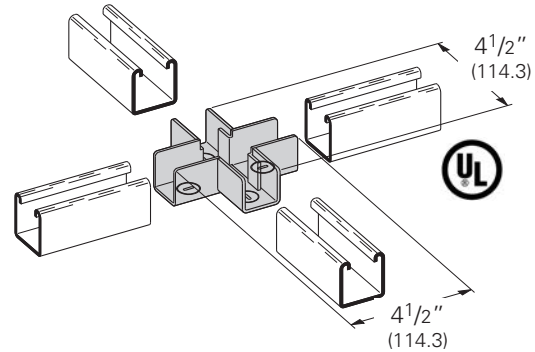

Part No.	For Channel Size	Wt./C	
		Lbs.	kg
B769-11	B11	148	(67.1)
B769-12	B12	120	(54.4)
B769-22 *	B22 & B24	87	(39.4)
B769-32	B32	78	(35.4)
B769-42	B42	65	(29.5)
B769-52	B52 & B54	58	(26.3)

* Cast aluminum parts

Note: Strut joiners are not for structural support. A channel support is recommended within 24" (609 mm) of each joint.

Reference page 206 for general fitting and standard finish specifications. U.L. Wire Fill Chart on pages 272 - 273.

Strut Joiners & Electrical Hardware

B166 Four Hole Splice Clevis

- Includes:
 - 1 Splice clevis
 - 4 pcs. 1/4"-20 Flat head machine screws
 - 4 pcs. N224WO channel nuts
- Material: 16 gauge (1.5)
- Standard finishes: ZN, GRN

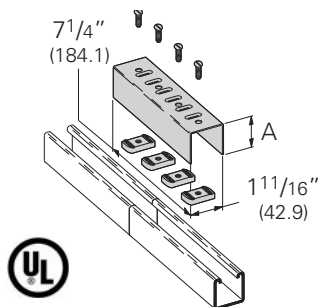

Part No.	A		For Channel Size	Wt./C	
	In.	mm		Lbs.	kg
B166-11	3 1/4"	(82.5)	B11	128	(58.0)
B166-12	2 7/16"	(61.9)	B12	108	(49.0)
B166-22	1 5/8"	(41.3)	B22, B24	91	(40.3)
B166-32	1 3/8"	(34.9)	B32	83	(37.6)
B166-42	1"	(25.4)	B42	75	(34.0)
B166-52	1 3/16"	(20.6)	B52, B54	71	(32.2)

B166-46 Four Hole Splice Clevis Assembly

- Requires ground wire for use with UL listed channel raceway system
- Includes:
 - 1 Splice clevis
 - 1 pc. B466W tapped plate
 - 4 pcs. 1/4"-20 Flat Head Machine Screws
- Material: 16 gauge (1.5)
- Standard finishes: ZN, GRN

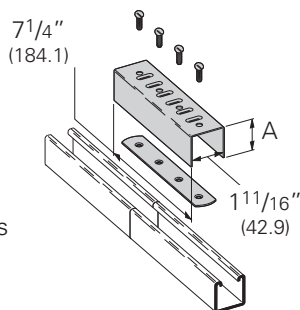

Part No.	A		For Channel Size	Wt./C	
	In.	mm		Lbs.	kg
B166-46-11	3 1/4"	(82.5)	B11	118	(53.5)
B166-46-12	2 7/16"	(61.9)	B12	98	(44.4)
B166-46-22	1 5/8"	(41.3)	B22, B24	79	(35.8)
B166-46-32	1 3/8"	(34.9)	B32	73	(33.1)
B166-46-42	1"	(25.4)	B42	65	(29.5)
B166-46-52	1 3/16"	(20.6)	B52, B54	61	(27.6)

B393-1 Wiring Stud

- Requires ground wire for use with UL listed channel raceway system
- 1/2" (15) pipe threads
- Material: Cast aluminum
- Wt./C 6 Lbs. (2.7 kg)

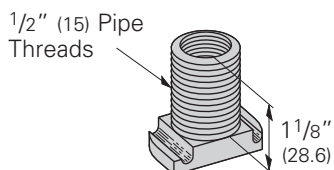

B589 Spacer Clevis

- Can be used with B393-1 wiring stud
- Material: 12 gauge (2.6)
- Standard finish: ZN
- Wt./C 29 Lbs. (13.1 kg)

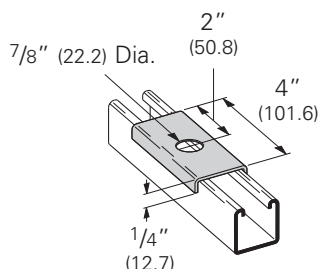

B619 Knock-Out Plate

- Requires ground wire for use with UL listed channel raceway system
- Includes: 2 pcs. 1/4"-20 Flat head machine screws
2 pcs. N224WO Channel nuts
- Material: 16 gauge (1.5) - 1/2" (15) conduit knockouts
- Standard finish: ZN
- Wt./C 40 Lbs. (18.1 kg)

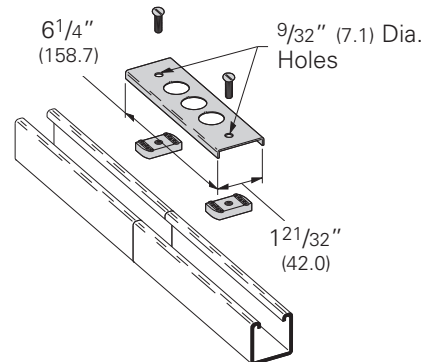

B166CL Splice Clevis Clip

- Use to cover gap between strut
- Material: 18 gauge (1.2)
- Standard finish: ZN
- Wt./C 4 Lbs. (1.8 kg)

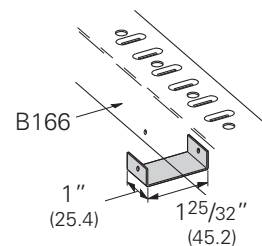

B590 Fiber Wire Retainer

- Installation aid for retaining wires before installing snap closure strip
- Wt./C 1 Lb. (.4 kg)

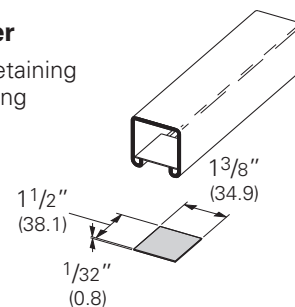

B617 Shoulder Bolt

- Standard finish: ZN
- Wt./C 6 Lbs. (2.7 kg)

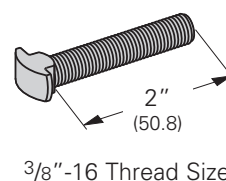

Reference page 206 for general fitting and standard finish specifications. U.L. Wire Fill Chart on pages 272 - 273.

Electrical Hardware & Porcelain Saddles

B446A Swivel Hanger (Female Only)

- Design Load:
(3/8)-610 Lbs. (2.71 kN)
(1/2)-1130 Lbs. (5.02 kN)
- Safety Factor of 3
- Standard finish: ZN

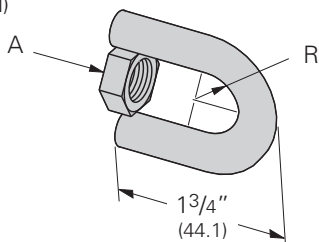

Part No.	A	R	Wt./C
	In.	mm	Lbs. kg
B446A-3/8	3/8"-16 HN	9/32" (7.1)	13 (5.9)
B446A-1/2	1/2"-13 HN	3/8" (9.5)	15 (6.8)

B446B Swivel Hanger (Male Only)

- Design Load:
(3/8)-610 Lbs. (2.71 kN)
(1/2)-1130 Lbs. (5.02 kN)
- Safety Factor of 3
- Standard finish: ZN

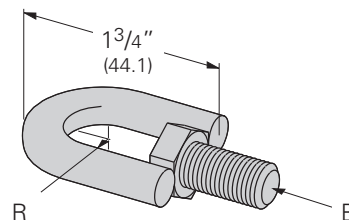

Part No.	A	R	Wt./C
	In.	mm	Lbs. kg
B446B-3/8	3/8"-16 HHCS	9/32" (7.1)	16 (7.2)
B446B-1/2	1/2"-13 HHCS	3/8" (9.5)	20 (9.1)

B446C Swivel Hanger (Female-Female)

- Design Load:
(3/8)-610 Lbs. (2.71 kN)
(1/2)-1130 Lbs. (5.02 kN)
- Safety Factor of 3
- Standard finish: ZN

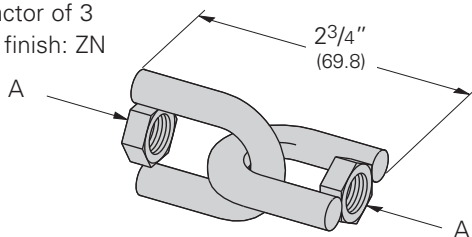

Part No.	A	Wt./C
	In.	Lbs. kg
B446C-3/8	3/8"-16 HN	26 (11.8)
B446C-1/2	1/2"-13 HN	31 (14.0)

B446 Swivel Hanger (Female-Male)

- Design Load:
(3/8)-610 Lbs. (2.71 kN)
(1/2)-1130 Lbs. (5.02 kN)
- Safety Factor of 3
- Standard finish: ZN

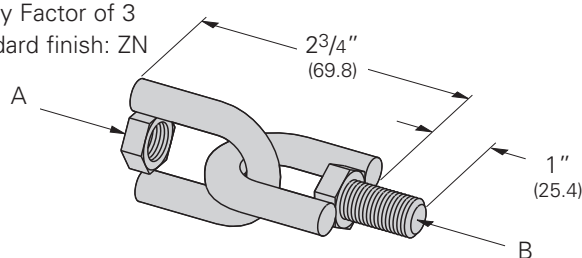

Part No.	A	B	Wt./C
	In.	In.	Lbs. kg
B446-3/8	3/8"-16 HN	3/8"-16 HHCS	28 (12.7)
B446-1/2	1/2"-13 HN	1/2"-13 HHCS	36 (16.3)

B4050 & B4051 Porcelain Cable Channel Saddle

- Electrical porcelain has an dielectric strength of 50 volts/mil

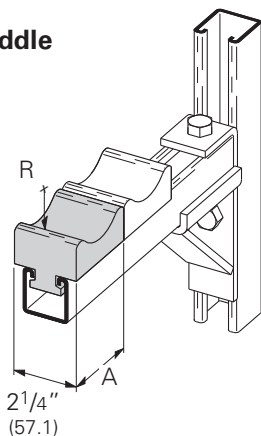

Part No.	A	R	Wt./C
	In.	mm	Lbs. kg
B4050	3" (76.2)	1 3/8" (34.9)	72 (32.6)
B4051	4" (101.6)	2 1/8" (54.0)	100 (45.3)

B4094 & B4095 Porcelain Cable Rack Saddle

- Electrical porcelain has an dielectric strength of 50 volts/mil
- Designed for use with B449 brackets

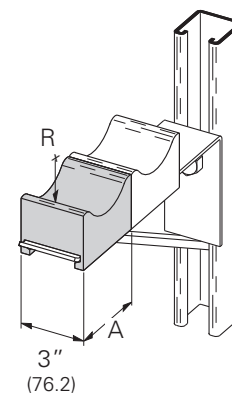

Part No.	A	R	Wt./C
	In.	mm	Lbs. kg
B4094	2 7/8" (73.0)	1 3/8" (34.9)	67 (30.4)
B4095	3 7/8" (98.4)	2 1/8" (54.0)	106 (48.1)

Reference page 206 for general fitting and standard finish specifications. U.L. Wire Fill Chart on pages 272 - 273.

Insulclamp Clamps

B4060 THRU B4093 Insulclamp™ Cable Clamps (Replaces porcelain clamps)

- Assembly includes:
1 Insulclamp & 1 pr. zinc plated pipe straps with Everdur (Silicon Bronze) hardware
- The thermoplastic elastomer Insulclamp has a dielectric strength of 640 volts/mil
- The flame retardant one piece design allows for trouble free assembly
- Everdur hardware is non-ferrous and prevents magnetic induction



OSO

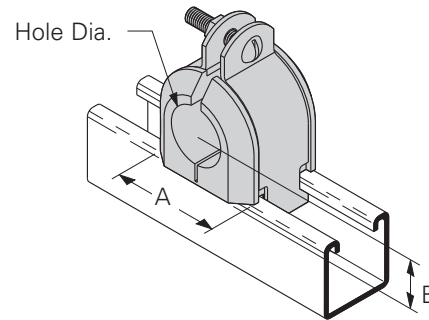

Part No.	Hole Dia.		Wt./C		A		B		Includes Clamp No.
	In.	mm	Lbs.	kg	In.	mm	In.	mm	
B4060	3/8"	(9.5)	25	(11.3)					
B4061	1/2"	(12.7)	25	(11.3)	1.36"	(34.5)	.56"	(14.2)	B2030
B4062	5/8"	(15.9)	25	(11.3)					
B4063	3/4"	(19.0)	37	(16.8)					
B4064	7/8"	(22.2)	37	(16.8)	1.86"	(47.2)	.81"	(20.8)	B2011
B4065	1"	(25.4)	37	(16.8)					
B4066	1 1/8"	(28.6)	37	(16.8)					
B4067	1 1/4"	(31.7)	58	(26.3)					
B4068	1 3/8"	(34.9)	58	(26.3)	2.36"	(59.9)	1.06"	(26.9)	B2038
B4069	1 1/2"	(38.1)	58	(26.3)					
B4070	1 5/8"	(41.3)	58	(26.3)					
B4071	1 3/4"	(44.4)	76	(34.5)					
B4072	1 7/8"	(47.6)	76	(34.5)	2.86"	(72.6)	1.31"	(33.3)	B2042
B4073	2"	(50.8)	76	(34.5)					
B4074	2 1/8"	(54.0)	76	(34.5)					
B4075	2 1/4"	(57.1)	90	(40.8)					
B4076	2 3/8"	(60.3)	90	(40.8)	3.36"	(85.3)	1.56"	(39.6)	B2046
B4077	2 1/2"	(63.5)	90	(40.8)					
B4078	2 5/8"	(66.7)	90	(40.8)					
B4079	2 3/4"	(69.8)	109	(49.4)					
B4080	2 7/8"	(73.0)	109	(49.4)	3.86"	(98.0)	1.81"	(46.0)	B2050
B4081	3"	(76.2)	109	(49.4)					
B4082	3 1/8"	(79.4)	109	(49.4)					
B4083	3 1/4"	(82.5)	130	(58.9)					
B4084	3 3/8"	(85.7)	130	(58.9)	4.36"	(110.7)	2.06"	(52.3)	B2054
B4085	3 1/2"	(88.9)	130	(58.9)					
B4086	3 5/8"	(92.1)	130	(58.9)					
B4087	3 3/4"	(95.2)	160	(72.6)					
B4088	3 7/8"	(98.4)	160	(72.6)	4.86"	(123.4)	2.31"	(58.7)	B2058
B4089	4"	(101.6)	160	(72.6)					
B4090	4 1/8"	(104.8)	160	(72.6)					
B4091	4 1/4"	(107.9)	160	(72.6)					
B4092	4 3/8"	(111.1)	160	(72.6)	5.24"	(133.1)	2.50"	(63.5)	B2018
B4093	4 1/2"	(114.3)	160	(72.6)					

4Dimension compatible fitting
open side only OSO

Reference page 206 for general fitting and standard finish specifications. U.L. Wire Fill Chart on pages 272 - 273.

Aluminum & Stainless Steel

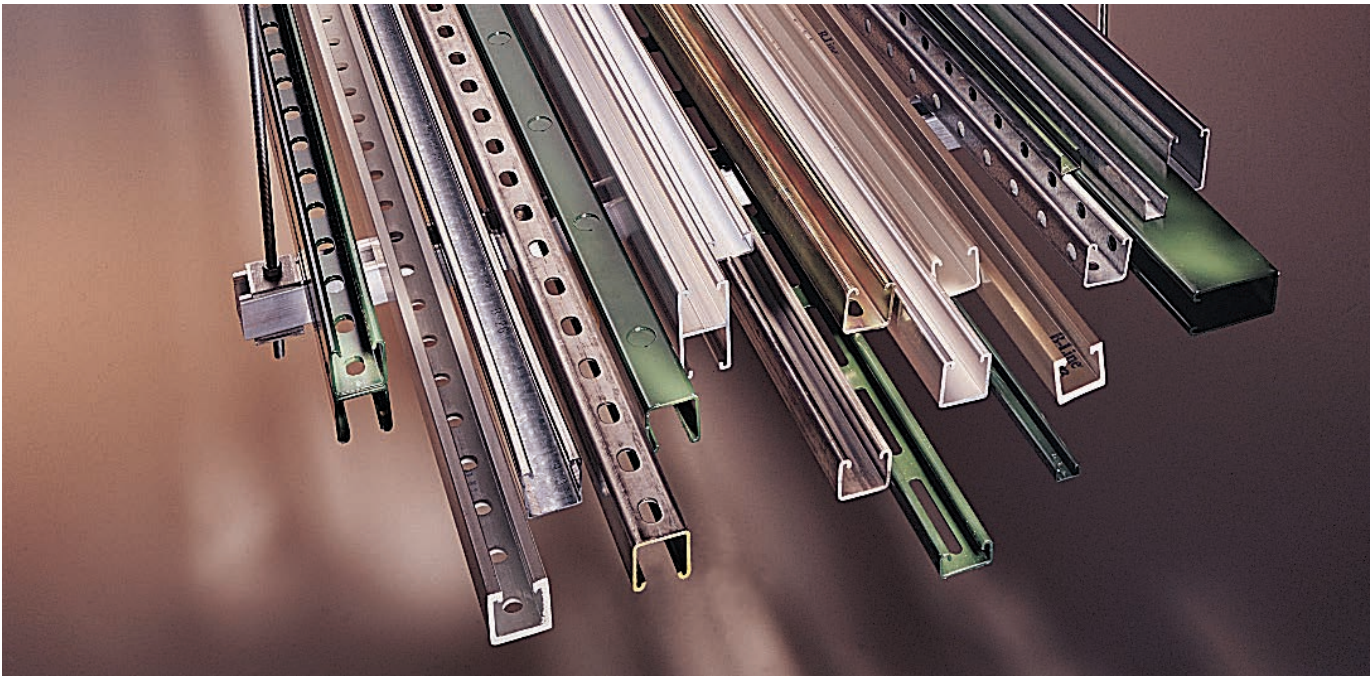

Aluminum

Aluminum channels, fittings and accessories offer excellent corrosion resistance and are suitable for many indoor and outdoor applications. Aluminum's high strength to weight ratio helps greatly reduce overall cost of installation through ease of handling and cutting. Channels are extruded from aluminum alloy 6063-T6. Closure strips are extruded from aluminum alloy 6063-T5. Fittings and accessories are made from aluminum alloy 5052-H32.

Stainless Steel

Where corrosion problems persist and other material and fittings are ineffective, we recommend use of corrosion resistant stainless steel channels and accessories. Channels and fittings are available in two types of stainless steel:

SS4-AISI Type 304

SS6-AISI Type 316

Fittings

Most fittings, as shown in this catalog, can be supplied in aluminum or stainless steel. Consult factory for possible minimum production quantities and set-up charges.

Load Data

Aluminum

Channel's approximate load data can be determined by multiplying load data in the steel channel section of this catalog by a factor of 0.38.

Stainless Steel

Channel load data is the same as the data in the steel channel section of this catalog.

Metric

Metric dimensions are shown in parentheses. Unless noted, all metric dimensions are in millimeters.

Aluminum Channel & Closure Strips

B11AL

- Thickness: .105 (2.6 mm)
- Standard Length: 10' (3.05 m) and 20' (6.09 m)
- Material: Aluminum
- Weight: 1.06 Lbs./Ft. (1.58 kg/m)

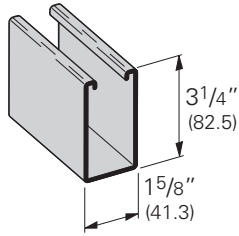

B12AL

- Thickness: .105 (2.6 mm)
- Standard Length: 10' (3.05 m) and 20' (6.09 m)
- Material: Aluminum
- Weight: .86 Lbs./Ft. (1.28 kg/m)

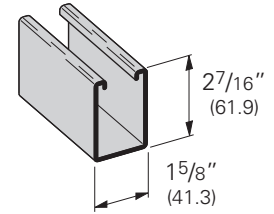

B22AL

- Thickness: .105 (2.6 mm)
- Standard Length: 10' (3.05 m) and 20' (6.09 m)
- Material: Aluminum
- Weight: .66 Lbs./Ft. (0.98 kg/m)

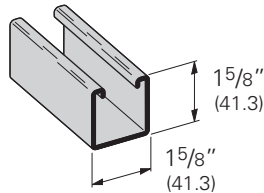

B22AAL

- Thickness: .105 (2.6 mm)
- Standard Length: 10' (3.05 m) and 20' (6.09 m)
- Material: Aluminum
- Weight: 1.18 Lbs./Ft. (1.75 kg/m)

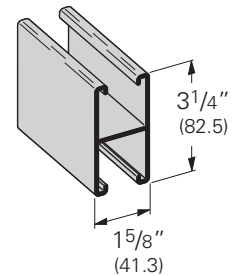

B54AL

- Thickness: .080 (2.0 mm)
- Standard Length: 10' (3.05 m) and 20' (6.09 m)
- Material: Aluminum
- Weight: .37 Lbs./Ft. (0.55 kg/m)

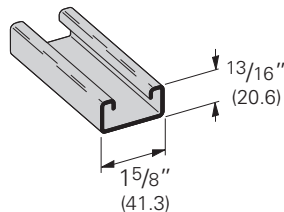

B54AAL

- Thickness: .080 (2.0 mm)
- Standard Length: 10' (3.05 m) and 20' (6.09 m)
- Material: Aluminum
- Weight: .57 Lbs./Ft. (0.84 kg/m)

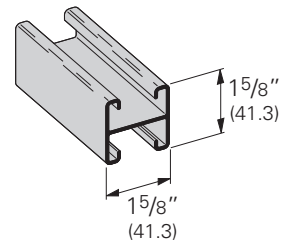

B217AL Closure Strip

- Standard Length: 10' (304.8 cm)
- Material: Aluminum
- Weight: .15 Lbs./Ft. (0.23 kg/m)

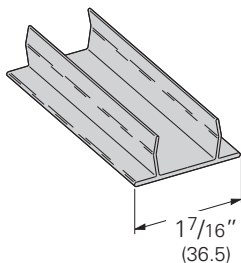

B217P Plastic Closure Strip

- Standard Length: 10' (304.8 cm)
- Material: PVC
- Weight: .09 Lbs./Ft. (0.14 kg/m)

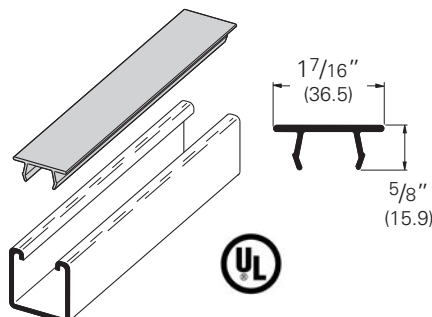

B217FFAL Closure Strip

- Standard Length: 10' (304.8 cm)
- Material: Aluminum
- Weight: .16 Lbs./Ft. (0.24 kg/m)

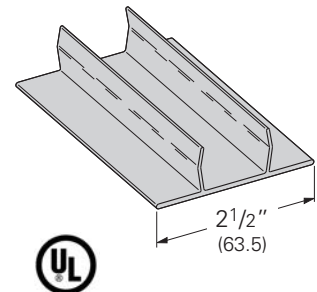

Reference page 218 for general fitting specifications. Other channel combinations available-see steel section for styles.

Aluminum

SH Type Channel

- Material: Aluminum

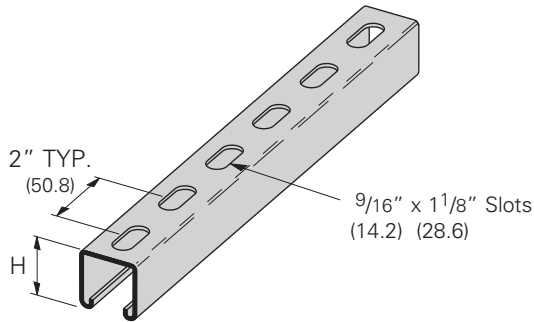

Part No.	Thickness		H		Wt./C	
	in.	mm	in.	mm	Lbs./Ft.	kg/m
B12SH AL	.105	(2.6)	27/16"	(61.9)	.83	(1.23)
B22SH AL	.105	(2.6)	15/8"	(41.3)	.63	(.93)
B54SH AL	.080	(2.0)	13/16"	(20.6)	.34	(.50)

H-17/8 Type Channel

- Material: Aluminum

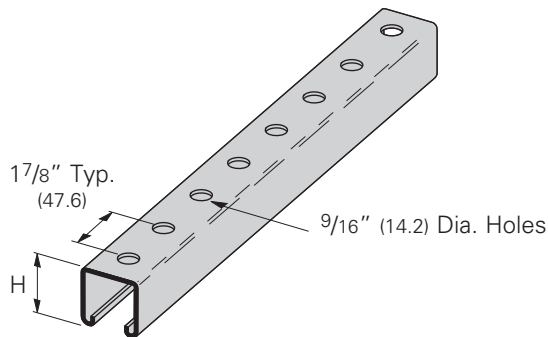

Part No.	Thickness		H		Wt./C	
	in.	mm	in.	mm	Lbs./Ft.	kg/m
B12H17/8 AL	.105	(2.6)	27/16"	(61.9)	.86	(1.28)
B22H17/8 AL	.105	(2.6)	15/8"	(41.3)	.66	(.98)
B54H17/8 AL	.080	(2.0)	13/16"	(20.6)	.37	(.55)

KO6 Type Knockout Channel

- Material: Aluminum

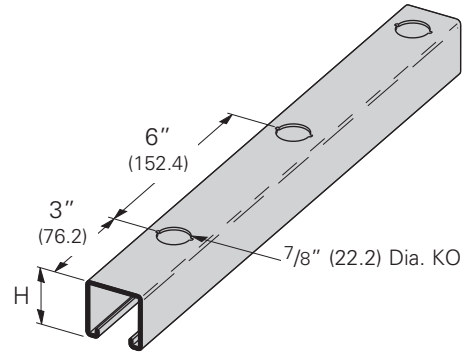

Part No.	Thickness		H		Wt./C	
	in.	mm	in.	mm	Lbs./Ft.	kg/m
B12KO6 AL	.105	(2.6)	27/16"	(61.9)	.86	(1.28)
B22KO6 AL	.105	(2.6)	15/8"	(41.3)	.66	(.98)
B54KO6 AL	.080	(2.0)	13/16"	(20.6)	.37	(.56)

B2000 Series Rigid Conduit Clamps

- Safety Factor of 5
- Machine Screw and Square Nut included
- Pipe clamp material 5052-H32

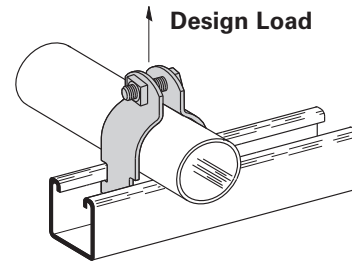

Part No.	Conduit or Pipe Size		Material Thickness	Design Load		Wt./C		
	in.	mm		Lbs.	kN	Lbs.	kg	
B2001 AL	3/8"	(10)	.063	(1.6)	180	(.80)	4	(1.8)
B2008 AL	1/2"	(15)	.063	(1.6)	180	(.80)	4	(1.8)
B2009 AL	3/4"	(20)	.080	(2.0)	270	(1.20)	6	(2.7)
B2010 AL	1"	(25)	.080	(2.0)	270	(1.20)	7	(3.2)
B2011 AL	1 1/4"	(32)	.080	(2.0)	270	(1.20)	8	(3.6)
B2012 AL	1 1/2"	(40)	.100	(2.5)	360	(1.60)	11	(5.0)
B2013 AL	2"	(50)	.100	(2.5)	360	(1.60)	12	(5.4)
B2014 AL	2 1/2"	(65)	.100	(2.5)	360	(1.60)	13	(5.9)
B2015 AL	3"	(80)	.100	(2.5)	360	(1.60)	16	(7.2)
B2016 AL	3 1/2"	(90)	.125	(3.2)	450	(2.00)	22	(10.0)
B2017 AL	4"	(100)	.125	(3.2)	450	(2.00)	24	(10.9)
B2018 AL	4 1/2"	(115)	.125	(3.2)	450	(2.00)	26	(11.8)
B2019 AL	5"	(125)	.125	(3.2)	450	(2.00)	27	(12.2)
B2020 AL	6"	(150)	.125	(3.2)	450	(2.00)	33	(14.9)

Reference page 218 for general fitting specifications. Other channel combinations available-see steel section for styles.

Aluminum Fittings

Most fittings, as shown in this catalog, can be supplied in aluminum. See "Fittings" section (page 106) of this catalog. Consult factory for possible minimum production quantities and set-up charges.

Channel Nuts

We recommend the use of Stainless Steel channel nuts with Aluminum channel. For channel nut pull-out strength and slip resistance, use the channel nut information provided on pg. 84 & 85.

A (.70) multiplier is to be applied to obtain the appropriate derated values for aluminum channel.

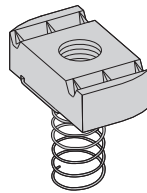

Spring Nut

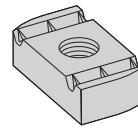

Nut Without Spring

Nuts for B12 Channel

Part Number		Thread Size	Thickness		Wt./C	
With Spring	Without Spring		in.	mm	Lbs.	kg
N724SS6	N224WOSS6	1/4"-20	1/4"	(6.3)	6.6	(3.0)
N728SS6	N228WOSS6	3/8"-16	3/8"	(9.5)	10.6	(4.8)
N725SS6	N225WOSS6	1/2"-13	3/8"	(9.5)	9.7	(4.4)

Nuts for B22, B24 Channels

Part Number		Thread Size	Thickness		Wt./C	
With Spring	Without Spring		in.	mm	Lbs.	kg
N224SS6	N224WOSS6	1/4"-20	1/4"	(6.3)	6.6	(3.0)
N228SS6	N228WOSS6	3/8"-16	3/8"	(9.5)	10.6	(4.8)
N225SS6	N225WOSS6	1/2"-13	3/8"	(9.5)	9.7	(4.4)

Nuts for B54 Channel

Part Number		Thread Size	Thickness		Wt./C	
With Spring	Without Spring		in.	mm	Lbs.	kg
N524SS6	N224WOSS6	1/4"-20	1/4"	(6.3)	6.6	(3.0)
N528SS6	N228WOSS6	3/8"-16	3/8"	(9.5)	10.6	(4.8)
N525SS6	N525WOSS6	1/2"-13	3/8"	(9.5)	9.7	(4.4)

Reference page 218 for general fitting specifications. Other channel combinations available-see steel section for styles.

Stainless Steel

B22SS

- Substitute 4 for Stainless Steel Type 304 or 6 for Stainless Steel Type 316
- Thickness: 12 Ga. (2.6 mm)
- Standard Length: 10' (3.05 m) and 20' (6.09 m)
- Material: SS4, SS6
- Weight: 1.90 Lbs./Ft. (2.83 kg/m)

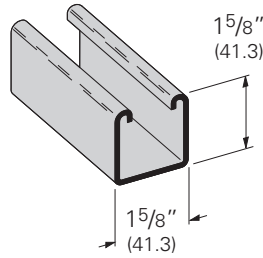

B24SS

- Substitute 4 for Stainless Steel Type 304 or 6 for Stainless Steel Type 316
- Thickness: 14 Ga. (1.9 mm)
- Standard Length: 10' (3.05 m) and 20' (6.09 m)
- Material: SS4, SS6
- Weight: 1.40 Lbs./Ft. (2.08 kg/m)

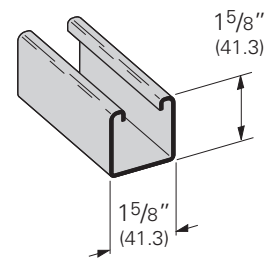

B32SS4

- Thickness: 12 Ga. (2.6 mm)
- Standard Length: 10' (3.05 m) and 20' (6.09 m)
- Material: SS4
- Weight: 1.70 Lbs./Ft. (2.53 kg/m)

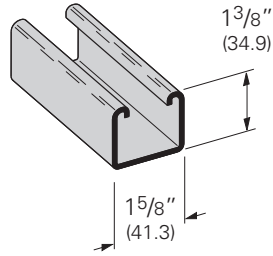

B42SS4

- Thickness: 12 Ga. (2.6 mm)
- Standard Length: 10' (3.05 m) and 20' (6.09 m)
- Material: SS4
- Weight: 1.44 Lbs./Ft. (2.14 kg/m)

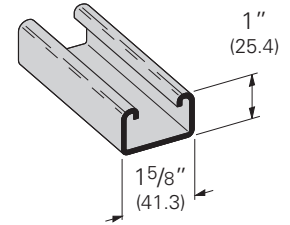

B52SS

- Substitute 4 for Stainless Steel Type 304 or 6 for Stainless Steel Type 316
- Thickness: 12 Ga. (2.6 mm)
- Standard Length: 10' (3.05 m) and 20' (6.09 m)
- Material: SS4, SS6
- Weight: 1.27 Lbs./Ft. (1.89 kg/m)

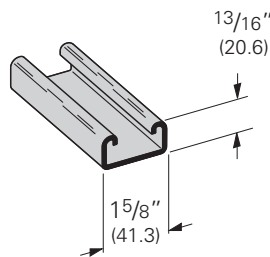

B54SS

- Substitute 4 for Stainless Steel Type 304 or 6 for Stainless Steel Type 316
- Thickness: 14 Ga. (1.9 mm)
- Standard Length: 10' (3.05 m) and 20' (6.09 m)
- Material: SS4, SS6
- Weight: .97 Lbs./Ft. (1.44 kg/m)

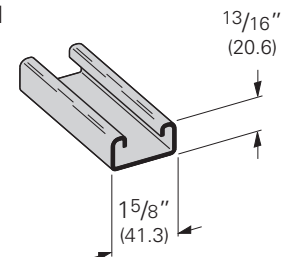

SH Type Channel

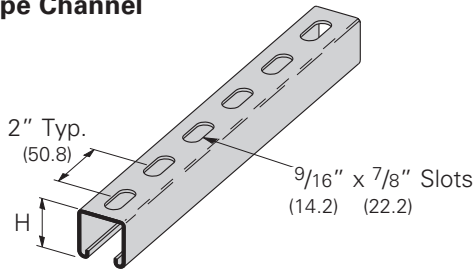

H-17/8 Type Channel

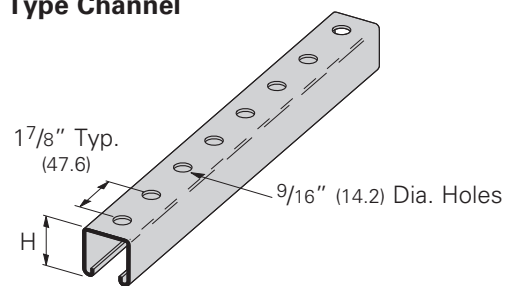

Part No.	Thickness in. mm	H in. mm	Wt./C Lbs./Ft. kg/m
B22SH SS4	12 Ga. (2.6)	1 5/8" (41.3)	1.82 (2.70)
B22SH SS6	12 Ga. (2.6)	1 5/8" (41.3)	1.82 (2.70)
B24SH SS4	14 Ga. (1.9)	1 5/8" (41.3)	1.34 (1.99)
B24SH SS6	14 Ga. (1.9)	1 5/8" (41.3)	1.34 (1.99)
B32SH SS4	12 Ga. (2.6)	1 3/8" (34.9)	1.62 (2.41)
B42SH SS4	12 Ga. (2.6)	1" (25.4)	1.36 (2.02)
B52SH SS4	12 Ga. (2.6)	1 3/16" (20.6)	1.23 (1.83)
B52SH SS6	12 Ga. (2.6)	1 3/16" (20.6)	1.23 (1.83)
B54SH SS4	14 Ga. (1.9)	1 3/16" (20.6)	.91 (1.35)
B54SH SS6	14 Ga. (1.9)	1 3/16" (20.6)	.91 (1.35)

Part No.	Thickness in. mm	H in. mm	Wt./C Lbs./Ft. kg/m
B22H17/8 SS4	12 Ga. (2.6)	1 5/8" (41.3)	1.85 (2.75)
B22H17/8 SS6	12 Ga. (2.6)	1 5/8" (41.3)	1.85 (2.75)
B24H17/8 SS4	14 Ga. (1.9)	1 5/8" (41.3)	1.36 (2.02)
B24H17/8 SS6	14 Ga. (1.9)	1 5/8" (41.3)	1.36 (2.02)
B32H17/8 SS4	12 Ga. (2.6)	1 3/8" (34.9)	1.65 (2.45)
B42H17/8 SS4	12 Ga. (2.6)	1" (25.4)	1.39 (2.07)
B52H17/8 SS4	12 Ga. (2.6)	1 3/16" (20.6)	1.20 (1.83)
B52H17/8 SS6	12 Ga. (2.6)	1 3/16" (20.6)	1.20 (1.83)
B54H17/8 SS4	14 Ga. (1.9)	1 3/16" (20.6)	.93 (1.38)
B54H17/8 SS6	14 Ga. (1.9)	1 3/16" (20.6)	.93 (1.38)

Reference page 218 for general fitting specifications. Other channel combinations available-see steel section for styles.

Stainless Steel Fittings

Most fittings, as shown in this catalog, can be supplied in Type 304 or Type 316 stainless steel. See "Fittings" section (page 106) of this catalog.

Consult factory for possible minimum production quantities and set-up charges.

B2000 Series Pipe & Tubing Clamps

- Safety Factor of 5
- Combination recess hex head machine screw and square nut included
- Material: Stainless Steel Type 304 & 316

Part No.	Conduit or Pipe Size		Material Thickness		Design Load		Wt./C	
	in.	mm	in.	mm	Lbs.	kN	Lbs.	kg
B2001 SS4	3/8"	(10)	16 Ga.	(1.5)	400	(1.78)	10	(4.5)
B2008 SS4	1/2"	(15)	16 Ga.	(1.5)	400	(1.78)	11	(5.0)
B2009 SS4	3/4"	(20)	14 Ga.	(1.9)	600	(2.67)	15	(6.8)
B2010 SS4	1"	(25)	14 Ga.	(1.9)	600	(2.67)	16	(7.2)
B2011 SS4	1 1/4"	(32)	14 Ga.	(1.9)	600	(2.67)	20	(9.1)
B2012 SS4	1 1/2"	(40)	12 Ga.	(2.6)	800	(3.56)	30	(13.6)
B2013 SS4	2"	(50)	12 Ga.	(2.6)	800	(3.56)	34	(15.4)
B2014 SS4	2 1/2"	(65)	12 Ga.	(2.6)	800	(3.56)	38	(17.2)
B2015 SS4	3"	(80)	12 Ga.	(2.6)	800	(3.56)	44	(19.9)
B2016 SS4	3 1/2"	(90)	12 Ga.	(2.6)	1000	(4.45)	51	(23.1)
B2017 SS4	4"	(100)	12 Ga.	(2.6)	1000	(4.45)	55	(24.9)
B2018 SS4	4 1/2"	(115)	12 Ga.	(2.6)	1000	(4.45)	59	(26.7)
B2019 SS4	5"	(125)	12 Ga.	(2.6)	1000	(4.45)	64	(29.0)
B2020 SS4	6"	(150)	12 Ga.	(2.6)	1000	(4.45)	80	(36.3)

Design Load

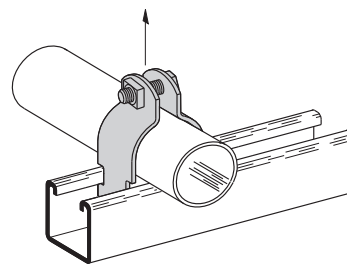

Channel Nuts

- For Channel Nuts pull-out strength and slip resistance, use the data shown on pages 84 & 85.

Note: Reduce slip load by 50% due to hardness of material.

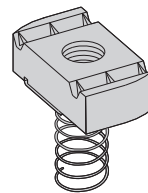

Spring Nut

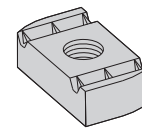

Nut Without Spring

Nuts for B22, B24, B32 Channels

Part Number		Thread Size	Thickness		Wt./C	
With Spring	Without Spring		in.	mm	Lbs.	kg
N224SS6	N224WOSS6	1/4"-20	1/4"	(6.3)	6.6	(3.0)
N228SS6	N228WOSS6	3/8"-16	3/8"	(9.5)	10.6	(4.8)
N225SS6	N225WOSS6	1/2"-13	3/8"	(9.5)	9.7	(4.4)

Nuts for B42, B52, B54 Channels

Part Number		Thread Size	Thickness		Wt./C	
With Spring	Without Spring		in.	mm	Lbs.	kg
N524SS6	N224WOSS6	1/4"-20	1/4"	(6.3)	6.6	(3.0)
N528SS6	N228WOSS6	3/8"-16	3/8"	(9.5)	10.6	(4.8)
N525SS6	N525WOSS6	1/2"-13	3/8"	(9.5)	9.7	(4.4)

Reference page 218 for general fitting specifications. Other channel combinations available-see steel section for styles.



We offer two fire retardant (FR) resins for strut systems: polyester and vinyl ester. Both resins are ideal for corrosive environments.

While polyester is sufficient for most uses, vinyl ester is suitable for a broader range of environments.

Please refer to the "Corrosion Resistance Guide" for specific applications, page 225.

Materials & Finishes

Our Fiberglass Strut systems are manufactured from glass fiber-reinforced plastic shapes that meet ASTM E-84, Class 1 Flame Rating and self-extinguishing requirements of ASTM D-635. A surface veil is applied during pultrusion to ensure a resin-rich surface and ultraviolet resistance.

Fittings

The following dimensions apply to all fittings except as noted on the drawings:

Hole Size – $1\frac{3}{32}$ " (10.3 mm) Dia.

Hole Spacing – $1\frac{3}{16}$ " (20.6 mm) from end and $1\frac{7}{8}$ " (47.6 mm) on center.

Width – $1\frac{5}{8}$ " (41.3 mm)

Thickness – $\frac{1}{4}$ " (6.3 mm)

Metric

Metric dimensions are shown in parentheses. Unless noted, all metric dimensions are in millimeters.

Channel Resin Information

We offer two fire retardant (FR) resins for strut systems, polyester and vinyl ester. Both resins are ideal for corrosive environments. While polyester is sufficient for most uses, vinyl ester is suitable for a broader range of environments. Please refer to the "Corrosion Resistance Guide" below for specific applications.

Corrosion Resistance Guide					
Chemicals	70°F (21°C)	160°F (71°C)	Chemicals	70°F (21°C)	160°F (71°C)
Acetic acid 5%	BFP/BFV	BFP/BFV	Methyl alcohol 10%	BFP/BFV	BFV-150° **
Acetic acid 52%	BFP/BFV	BFV-210° **	Naphtha	BFP/BFV	BFP/BFV
Aluminum potassium sulfate 5%	BFP/BFV	BFP/BFV	Nitric acid 5%	BFP/BFV	BFP/BFV
Ammonium hydroxide 10%	BFP/BFV	BFV-150° **	Nitric acid 20%	BFV	BFV-120° **
Ammonium nitrate	BFP/BFV	BFP/BFV	Phosphoric acid 10%	BFP/BFV	BFP/BFV
Benzene sulfonic acid 5%	BFP/BFV	BFP/BFV	Phosphoric acid 30%	BFP/BFV	BFP/BFV
Calcium chloride	BFP/BFV	BFP/BFV	Phosphoric acid 85%	BFP/BFV	BFP/BFV
Carbon tetrachloride	BFV	BFV-100° **	Sodium bicarbonate 10%	BFP/BFV	BFP/BFV
Chlorine dioxide 15%	BFP/BFV	BFV-150° **	Sodium bisulfate	BFP/BFV	BFP/BFV
Chromic acid 5%	BFV	BFV-150° **	Sodium carbonate	BFP/BFV	BFV
Copper sulfate	BFP/BFV	BFP/BFV	Sodium chloride	BFP/BFV	BFP/BFV
Diesel fuel	BFP/BFV	BFV	Sodium hydroxide 1-50%	BFV	BFV-120° **
Ethylene glycol	BFP/BFV	BFP/BFV	Sodium hypochlorite 5%	BFP/BFV	BFV-120° **
Fatty acids 100%	BFP/BFV	BFP/BFV	Sodium nitrate	BFP/BFV	BFP/BFV
Ferrous sulfate	BFP/BFV	BFP/BFV	Sodium silicate	BFP/BFV	BFV-210° **
Fluosilicic acid 0-20%	BFV	BFV	Sodium sulfate	BFP/BFV	BFP/BFV
Gasoline	BFP/BFV	BFV	Sulfuric acid 0-30%	BFP/BFV	BFP/BFV
Hydrochloric acid 1%	BFP/BFV	BFP/BFV	Sulfuric acid 30-50%	BFV	BFV
Hydrochloric acid 15%	BFP/BFV	BFV-180° **	Sulfuric acid 50-70%	BFV	BFV-180° **
Hydrochloric acid 37%	BFP/BFV	BFV-150° **	Trisodium phosphate 25%	BFP/BFV	BFV-210° **
Kerosene	BFP/BFV	BFP/BFV	Trisodium phosphate-All	BFV	BFV-210° **
Magnesium chloride	BFP/BFV	BFP/BFV	Water, Distilled	BFP/BFV	BFP/BFV

BFP - BFP parts recommended BFV - BFV parts recommended ** - Not recommended to exceed this temperature

Information contained in this chart is based on data from raw material suppliers.

Temperatures are not the minimum nor the maximum (except where specifically stated) but represent standard test conditions. The products may be suitable at higher temperatures but individual test data should be required to establish suitability.

The recommendations or suggestions contained in this chart are made without guarantee or representation as to results. We suggest that you evaluate the recommendations and suggestions in your own laboratory or actual field trial prior to use.

Recommended Guideline:

Temperature	Design Load Multiplier
75°F (24°C)	100%
100°F (38°C)	90%
125°F (52°C)	78%
150°F (66°C)	68%
175°F (79°C)	60%
200°F (93°C)	52%

Flame Retardant Properties	BFP	BFV
Flame Resistance (FTMS 406-2023) ign/burn, seconds	75/75	75/75
Intermittent Flame Test (HLT-15), rating	100	100
Flammability Test (ASTM D635) Ignition Burning Time	none 0 sec.	none 0 sec.
Surface Burning Characteristics (ASTM E84), Flame spread index	25	25
UL 94 Flame Class	V-0	V-0

Reference page 224 for general fitting specifications.

Fiberglass

BFP22 THRU BFV22SH

- Channel lengths: 10 Ft. (3.05 m) and 20 Ft. (6.09 m)
- Fiberglass strut meets specification of ASTM D-4385 Levels III and IV.

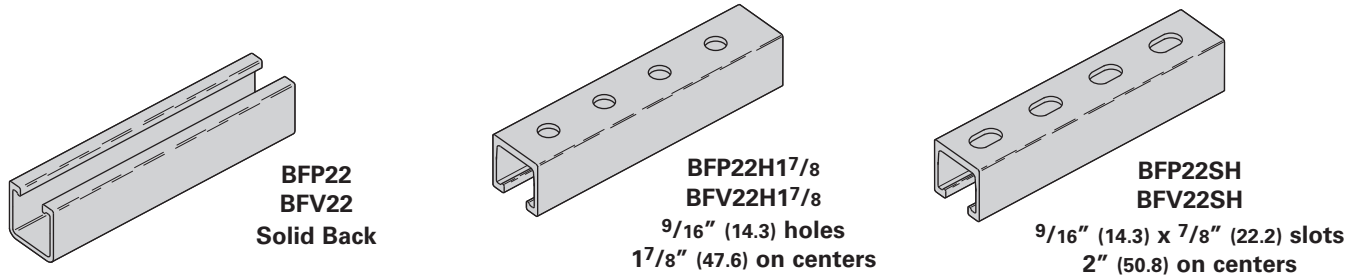

Part No.	Material	Description	Color	Weight	
				Lbs./ft.	kg/m
BFP22*	Polyester Resin	Solid Back	Gray	.63	(.94)
BFV22*	Vinyl Ester Resin	Solid Back	Beige	.63	(.94)
BFP22H17/8*	Polyester Resin	Holes in Back	Gray	.60	(.89)
BFV22H17/8*	Vinyl Ester Resin	Holes in Back	Beige	.60	(.89)
BFP22SH*	Polyester Resin	Slots in Back	Gray	.61	(.91)
BFV22SH*	Vinyl Ester Resin	Slots in Back	Beige	.61	(.91)

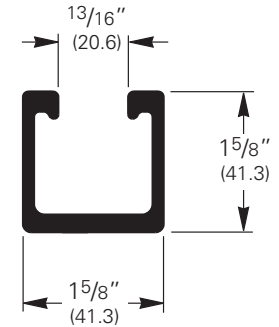

* Insert -10 for 10'-0" (3.05 m) length or -20 for 20'-0" (6.09 m) length

BFP22A BFV22A

- Channel Lengths: 10 Ft. (3.05 m) and 20 Ft. (6.09 m)
- Fiberglass strut meets specification of ASTM D-4385 Levels III and IV.

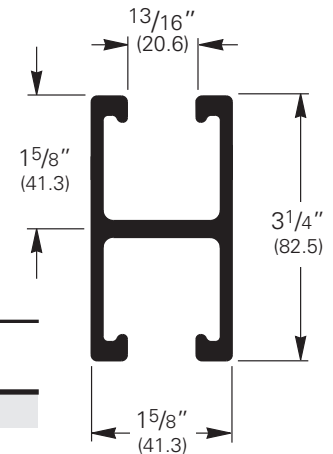
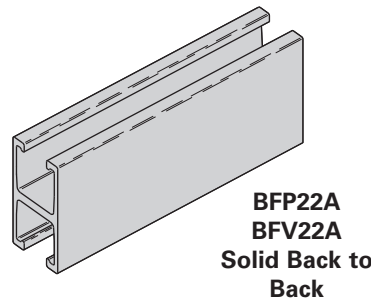

Part No.	Material	Description	Color	Weight	
				Lbs./ft.	kg/m
BFP22A*	Polyester Resin	Back To Back	Gray	1.15	(1.71)
BFV22A*	Vinyl Ester Resin	Back To Back	Beige	1.15	(1.71)

* Insert -10 for 10'-0" (3.05 m) length or -20 for 20'-0" (6.09 m) length

Field Cutting Sealant Kits

RSK010

- Pint Sealing Kit (473 cm³) includes sealant and brush applicator
- Seals exposed fibers after field cutting
- UV resistant



APPROPRIATE PROTECTIVE CLOTHING AND RESPIRATORY PROTECTION DEVICE SHOULD BE WORN WHEN FIELD CUTTING OR GRINDING FIBERGLASS.

Published design loads on page 227 are based on usage at 70°F (21°C) and must be reduced for continuous exposure to higher temperatures. Refer to the chart below for high temperature applications.

Temperature	Design Load Multiplier
75°F (24°C)	100%
100°F (38°C)	90%
125°F (52°C)	78%
150°F (66°C)	68%
175°F (79°C)	60%
200°F (93°C)	52%

Reference page 224 for general fitting specifications.

Beam Loading Data for Glass Reinforced Polyester Resin

Beam Span		Part No.	Maximum Allowable Beam Load		Deflection @ Maximum Allowable Beam Load		Allowable Load @ Deflection =				
			Lbs.	kN	in.	mm	1/240 Span		1/360 Span		
in.	mm							Lbs.	kN	Lbs.	kN
12"	(305)	BFP22	1781	(7.92)	0.064	(1.62)	1392	(6.19)	928	(4.13)	
		BFP22A	2259	(10.05)	0.037	(.94)	2259	(10.05)	2051	(9.12)	
24"	(609)	BFP22	890	(3.96)	0.256	(6.50)	347	(1.54)	231	(1.03)	
		BFP22A	1127	(5.01)	0.147	(3.73)	767	(3.41)	511	(2.27)	
36"	(914)	BFP22	592	(2.63)	0.576	(14.63)	153	(0.68)	101	(0.45)	
		BFP22A	750	(3.33)	0.330	(8.38)	338	(1.50)	224	(0.99)	
48"	(1219)	BFP22	443	(1.97)	1.024	(26.01)	85	(0.38)	55	(0.24)	
		BFP22A	560	(2.49)	0.587	(14.91)	188	(0.83)	123	(0.55)	
60"	(1524)	BFP22	353	(1.57)	1.600	(40.64)	53	(0.23)	34	(0.15)	
		BFP22A	446	(1.98)	0.918	(23.32)	117	(0.52)	76	(0.34)	
72"	(1829)	BFP22	293	(1.30)	2.303	(58.49)	35	(0.15)	22	(0.10)	
		BFP22A	370	(1.64)	1.322	(33.58)	78	(0.34)	50	(0.22)	
96"	(2438)	BFP22	218	(0.97)	4.095	(104.01)	17	(0.07)	9	(0.04)	
		BFP22A	273	(1.21)	2.350	(59.69)	39	(0.17)	23	(0.10)	
120"	(3048)	BFP22	172	(0.76)	6.398	(162.51)	8	(0.03)	3	(0.01)	
		BFP22A	214	(0.95)	3.671	(93.24)	19	(0.08)	9	(0.04)	

Beam Loading Data for Glass Reinforced Vinyl Ester Resin

Beam Span		Part No.	Maximum Allowable Beam Load		Deflection @ Maximum Allowable Beam Load		Allowable Load @ Deflection =				
			Lbs.	kN	in.	mm	1/240 Span		1/360 Span		
in.	mm							Lbs.	kN	Lbs.	kN
12"	(305)	BFV22	2220	(9.87)	0.071	(1.80)	1568	(6.97)	1045	(4.65)	
		BFV22A	6442	(28.65)	0.039	(0.99)	6442	(29.65)	5549	(24.68)	
24"	(609)	BFV22	1109	(4.93)	0.283	(7.19)	391	(1.74)	260	(1.15)	
		BFV22A	3219	(14.32)	0.155	(3.94)	2079	(9.25)	1385	(6.16)	
36"	(914)	BFV22	738	(3.28)	0.637	(16.18)	172	(0.76)	114	(0.51)	
		BFV22A	2144	(9.53)	0.348	(8.84)	922	(4.10)	613	(2.72)	
48"	(1219)	BFV22	553	(2.46)	1.133	(28.78)	96	(0.43)	63	(0.28)	
		BFV22A	1606	(7.14)	0.619	(15.72)	516	(2.29)	342	(1.52)	
60"	(1524)	BFV22	441	(1.96)	1.770	(44.96)	60	(0.26)	39	(0.17)	
		BFV22A	1283	(5.70)	0.967	(24.56)	327	(1.45)	216	(0.96)	
72"	(1829)	BFV22	366	(1.63)	2.549	(64.74)	40	(0.18)	25	(0.11)	
		BFV22A	1067	(4.74)	1.393	(35.38)	224	(0.99)	147	(0.65)	
96"	(2438)	BFV22	273	(1.21)	4.531	(115.09)	19	(0.08)	11	(0.05)	
		BFV22A	796	(3.54)	2.477	(62.91)	121	(0.54)	78	(0.34)	
120"	(3048)	BFV22	216	(0.96)	7.079	(179.80)	9	(0.04)	7	(0.02)	
		BFV22A	633	(2.81)	3.870	(98.30)	72	(0.32)	44	(0.19)	

Loading Information

Beam Loads:

The above charts list the total allowable uniform load for various simple spans based on a minimum safety factor of 2. If the load is concentrated at center span, multiply the load from the above charts by 0.5 and the corresponding deflection by 0.8.

All beams should be supported in a manner to prevent rotation at supports. Long, deep beams should be tied between supports to prevent twist. For channels with holes or slots use 90% of recommended load shown in channel loading chart.

Reference page 224 for general fitting specifications.

Fiberglass

BFP42 thru BFV42SH

- Channel lengths: 10 Ft. (3.05 m) and 20 Ft. (6.09 m)
- Fiberglass strut meets specification of ASTM D-4385 Levels III and IV.

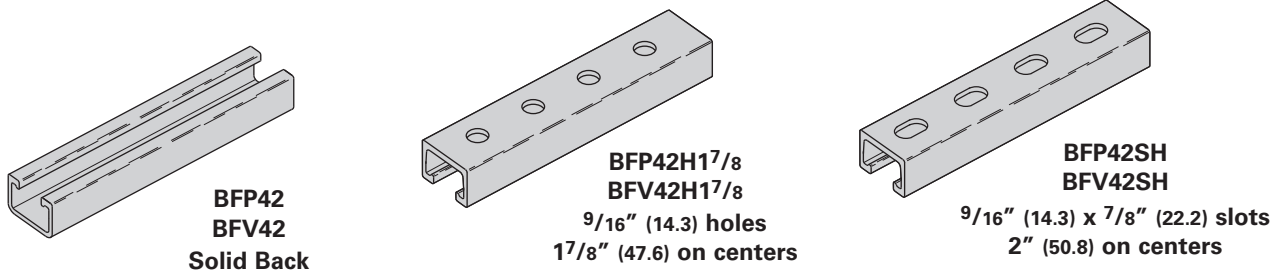

Part No.	Material	Description	Color	Weight	
				Lbs./ft.	kg/m
BFP42*	Polyester Resin	Solid Back	Gray	.48	(.71)
BFV42*	Vinyl Ester Resin	Solid Back	Beige	.48	(.71)
BFP42H1^{7/8}*	Polyester Resin	Holes in Back	Gray	.46	(.68)
BFV42H1^{7/8}*	Vinyl Ester Resin	Holes in Back	Beige	.46	(.68)
BFP42SH*	Polyester Resin	Slots in Back	Gray	.47	(.70)
BFV42SH*	Vinyl Ester Resin	Slots in Back	Beige	.47	(.70)

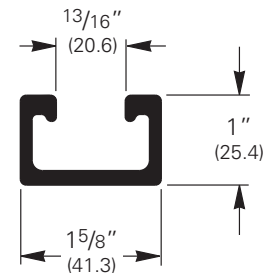

* Insert -10 for 10'-0" (3.05 m) length or -20 for 20'-0" (6.09 m) length

BFP42A BFV42A

- Channel lengths: 10 Ft. (3.05 m) and 20 Ft. (6.09 m)
- Fiberglass strut meets specification of ASTM D-4385 Levels III and IV.

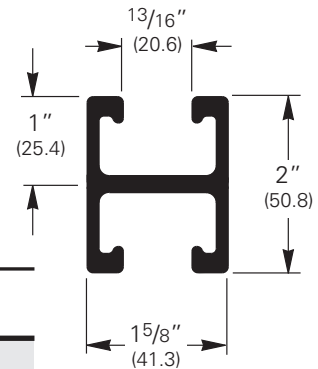
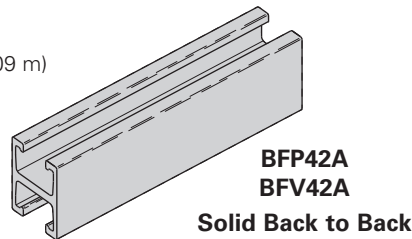

Part No.	Material	Description	Color	Weight	
				Lbs./ft.	kg/m
BFP42A*	Polyester Resin	Back To Back	Gray	.85	(1.26)
BFV42A*	Vinyl Ester Resin	Back To Back	Beige	.85	(1.26)

* Insert -10 for 10'-0" (3.05 m) length or -20 for 20'-0" (6.09 m) length

Published design loads on page 229 are based on usage at 70°F (21°C) and must be reduced for continuous exposure to higher temperatures. Refer to the chart below for high temperature applications.

Temperature	Design Load Multiplier
75°F (24°C)	100%
100°F (38°C)	90%
125°F (52°C)	78%
150°F (66°C)	68%
175°F (79°C)	60%
200°F (93°C)	52%

Field Cutting Sealant Kits

RSK010

- Pint Sealing Kit (473 cm³) includes sealant and brush applicator
- Seals exposed fibers after field cutting
- UV resistant



APPROPRIATE PROTECTIVE CLOTHING AND RESPIRATORY PROTECTION DEVICE SHOULD BE WORN WHEN FIELD CUTTING OR GRINDING FIBERGLASS.

Reference page 224 for general fitting specifications.

Beam Loading Data for Glass Reinforced Polyester Resin

Beam Span		Part No.	Maximum Allowable Beam Load		Deflection @ Maximum Allowable Beam Load		Allowable Load @ Deflection =				
			Lbs.	kN	in.	mm	1/240 Span		1/360 Span		
in.	mm							Lbs.	kN	Lbs.	kN
12"	(305)	BFP42	841	(3.74)	0.104	(2.64)	403	(1.79)	269	(1.19)	
		BFP42A	2325	(10.34)	0.060	(1.52)	1948	(8.66)	1299	(5.78)	
24"	(609)	BFP42	420	(1.87)	0.417	(10.59)	100	(0.44)	66	(0.29)	
		BFP42A	1161	(5.16)	0.239	(6.07)	486	(2.16)	323	(1.43)	
36"	(914)	BFP42	279	(1.24)	0.938	(23.82)	43	(0.19)	29	(0.13)	
		BFP42A	773	(3.44)	0.537	(13.64)	214	(0.95)	142	(0.63)	
48"	(1219)	BFP42	208	(0.92)	1.667	(42.34)	23	(0.10)	15	(0.06)	
		BFP42A	578	(2.57)	0.955	(24.26)	119	(0.53)	78	(0.34)	
60"	(1524)	BFP42	166	(0.74)	2.604	(66.14)	14	(0.06)	8	(0.03)	
		BFP42A	461	(2.05)	1.491	(37.87)	74	(0.33)	48	(0.21)	
72"	(1829)	BFP42	137	(0.61)	3.750	(95.25)	8	(0.03)	5	(0.02)	
		BFP42A	383	(1.70)	2.148	(54.56)	49	(0.22)	31	(0.14)	
96"	(2438)	BFP42	101	(0.45)	6.667	(169.34)	3	(0.01)	–	–	
		BFP42A	284	(1.26)	3.818	(96.98)	24	(0.10)	14	(0.04)	
120"	(3048)	BFP42	79	(0.35)	10.417	(264.59)	–	–	–	–	
		BFP42A	224	(0.99)	5.966	(151.53)	11	(0.05)	5	(0.02)	

Beam Loading Data for Glass Reinforced Vinyl Ester Resin

Beam Span		Part No.	Maximum Allowable Beam Load		Deflection @ Maximum Allowable Beam Load		Allowable Load @ Deflection =				
			Lbs.	kN	in.	mm	1/240 Span		1/360 Span		
in.	mm							Lbs.	kN	Lbs.	kN
12"	(305)	BFV42	988	(4.39)	0.112	(2.84)	440	(1.96)	293	(1.30)	
		BFV42A	2865	(12.74)	0.063	(1.60)	2278	(10.13)	1518	(6.75)	
24"	(609)	BFV42	493	(2.19)	0.448	(11.38)	109	(0.48)	73	(0.32)	
		BFV42A	1431	(6.36)	0.252	(6.40)	568	(2.52)	378	(1.68)	
36"	(914)	BFV42	328	(1.46)	1.009	(25.63)	48	(0.21)	31	(0.14)	
		BFV42A	953	(4.24)	0.566	(14.37)	251	(1.11)	166	(0.74)	
48"	(1219)	BFV42	245	(1.09)	1.793	(45.54)	26	(0.11)	16	(0.07)	
		BFV42A	713	(3.17)	1.006	(25.55)	139	(0.62)	92	(0.41)	
60"	(1524)	BFV42	195	(0.87)	2.802	(71.17)	15	(0.06)	9	(0.04)	
		BFV42A	569	(2.53)	1.572	(39.93)	87	(0.38)	57	(0.25)	
72"	(1829)	BFV42	162	(0.72)	4.035	(102.49)	9	(0.04)	5	(0.02)	
		BFV42A	473	(2.10)	2.264	(57.50)	58	(0.26)	37	(0.16)	
96"	(2438)	BFV42	120	(0.53)	7.173	(182.19)	3	(0.01)	1	(0.004)	
		BFV42A	351	(1.56)	4.025	(102.23)	29	(0.13)	17	(0.07)	
120"	(3048)	BFV42	94	(0.42)	11.207	(284.66)	–	–	–	–	
		BFV42A	278	(1.23)	6.288	(159.71)	14	(0.06)	7	(0.03)	

Loading Information

Beam Loads:

The above charts list the total allowable uniform load for various simple spans based on a minimum safety factor of 2. If the load is concentrated at center span, multiply the load from the above charts by 0.5 and the corresponding deflection by 0.8. All beams should be supported in a manner to prevent rotation at supports. Long, deep beams should be tied between supports to prevent twist. For channels with holes or slots use 90% of recommended load shown in channel loading chart.

Reference page 224 for general fitting specifications.

Fiberglass

BFV501 Series U-Bolts with Hex Nuts

- Design Load Safety Factor of 3
- Load A: Straight down loading
- Load B: Side loading
- Inner surface of U-Bolt is flat to provide additional contact surface area
- Material: Glass reinforced polyurethane

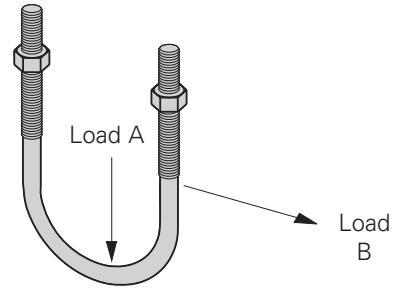

Part No.	Nominal Pipe Size		Thread Size	Design Load A		Design Load B		Maximum Torque		Wt./C	
	in.	mm		Lbs.	kN	Lbs.	kN	in.-Lbs.	N•m	Lbs.	kg
BFV501-1/2	1/2	(15)	3/8"-16	300	(1.33)	150	(.67)	30	(3.4)	3.5	(1.59)
BFV501-3/4	3/4	(20)	3/8"-16	300	(1.33)	150	(.67)	30	(3.4)	3.9	(1.77)
BFV501-1	1	(25)	3/8"-16	300	(1.33)	150	(.67)	30	(3.4)	4.4	(1.99)
BFV501-1 1/4	1 1/4	(32)	3/8"-16	300	(1.33)	150	(.67)	30	(3.4)	4.8	(2.18)
BFV501-1 1/2	1 1/2	(40)	3/8"-16	300	(1.33)	150	(.67)	30	(3.4)	5.2	(2.36)
BFV501-2	2	(50)	1/2"-13	600	(2.67)	200	(.89)	60	(6.8)	7.7	(3.49)
BFV501-2 1/2	2 1/2	(65)	1/2"-13	600	(2.67)	200	(.89)	60	(6.8)	10.2	(4.63)
BFV501-3	3	(80)	1/2"-13	600	(2.67)	200	(.89)	60	(6.8)	12.6	(5.71)
BFV501-3 1/2	3 1/2	(90)	1/2"-13	600	(2.67)	200	(.89)	60	(6.8)	15.1	(6.85)
BFV501-4	4	(100)	1/2"-13	600	(2.67)	200	(.89)	60	(6.8)	17.6	(7.98)

Channel Nuts

- Design Load Safety Factor of 3
- Overall Nut Height 5/8" (15.9)
- Maximum torque and slip resistance loads shown are when using stainless steel bolts. When using fiberglass hardware use Max. Torque for fiberglass bolts, and multiply slip resistance loads by .14 for 3/8"-16 and .60 for 1/2"-13 thread size.
- Material: Glass reinforced polyurethane
- Spring Material: Zinc plated steel

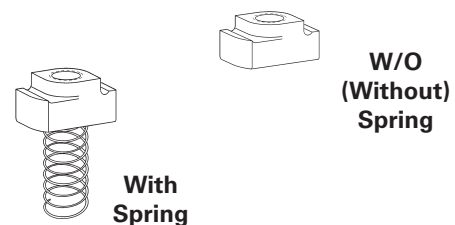

Part No.		Thread Size	Pull-Out		Slip Resistance		Max. Torque		Wt./C	
With Spring	W/O Spring		Lbs.	kN	Lbs.	N	in.-Lbs.	N•m	Lbs.	kg
BFV-224	BFV-224WO	1/4"-20	300	(1.33)	150	(.67)	200	(22.6)	2.4	(1.09)
BFV-223	BFV-223WO	5/16"-18	300	(1.33)	150	(.67)	200	(22.6)	2.5	(1.13)
BFV-228	BFV-228WO	3/8"-16	300	(1.33)	150	(.67)	200	(22.6)	2.3	(1.04)
BFV-225	BFV-225WO	1/2"-13	300	(1.33)	150	(.67)	200	(22.6)	2.1	(0.95)

Reference page 224 for general fitting specifications.

BFVHHCS Hex Head Cap Screws

- Design Load Safety Factor of 3
- Material: Glass reinforced polyurethane

Part No.	Thread Size	Design Load (in tension)		Max. Torque		Wt./C	
		Lbs.	kN	in.-Lbs.	N•m	Lbs.	kg
BFVHHCS 5/16 x 1	5/16"-18	190	(.84)	30	(3.4)	.4	(.18)
BFVHHCS 5/16 x 1 1/4	5/16"-18	190	(.84)	30	(3.4)	.5	(.23)
BFVHHCS 5/16 x 1 1/2	5/16"-18	190	(.84)	30	(3.4)	.6	(.27)
BFVHHCS 5/16 x 2	5/16"-18	190	(.84)	30	(3.4)	.8	(.36)
BFVHHCS 3/8 x 1	3/8"-16	300	(1.33)	45	(5.1)	.9	(.41)
BFVHHCS 3/8 x 1 1/4	3/8"-16	300	(1.33)	45	(5.1)	1.1	(.50)
BFVHHCS 3/8 x 1 1/2	3/8"-16	300	(1.33)	45	(5.1)	1.3	(.59)
BFVHHCS 3/8 x 2	3/8"-16	300	(1.33)	45	(5.1)	1.3	(.59)
BFVHHCS 3/8 x 2 1/2	3/8"-16	300	(1.33)	45	(5.1)	1.5	(.68)
BFVHHCS 1/2 x 1	1/2"-13	490	(2.18)	110	(12.4)	1.4	(.63)
BFVHHCS 1/2 x 1 1/4	1/2"-13	490	(2.18)	110	(12.4)	1.8	(.81)
BFVHHCS 1/2 x 1 1/2	1/2"-13	490	(2.18)	110	(12.4)	2.2	(1.00)
BFVHHCS 1/2 x 2	1/2"-13	490	(2.18)	110	(12.4)	3.0	(1.36)
BFVHHCS 1/2 x 2 1/2	1/2"-13	490	(2.18)	110	(12.4)	3.7	(1.68)
BFVHHCS 1/2 x 3	1/2"-13	490	(2.18)	110	(12.4)	4.5	(2.04)

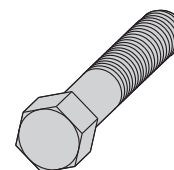

BFVHN Hex Nuts

- 3/4" & 1" sizes are available. Contact inside sales for details
- Material: Glass reinforced polyurethane

Part No.	Thread Size	Nut Thickness		Wt./C	
		in.	mm	Lbs.	kg
BFVHN 5/16	5/16"-18	17/64	(6.7)	.2	(.09)
BFVHN 3/8	3/8"-16	21/64	(8.3)	.3	(.13)
BFVHN 1/2	1/2"-13	7/16	(11.1)	.7	(.32)
BFVHN 5/8	5/8"-11	35/64	(13.9)	1.4	(.63)

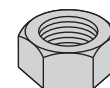

Reference page 224 for general fitting specifications.

Fiberglass

BFVATR All Threaded Rod

- Design Load Safety Factor of 3
- Design Load can be increased by 40% if a second ATR nut is used.
- Use ATR nuts in place of hex nuts with 3/8"-16 and 1/2"-13 threaded rod in order to obtain minimum required thread engagement of 17/32" (13.5) to obtain design load shown below.
- Material: Glass reinforced vinyl ester

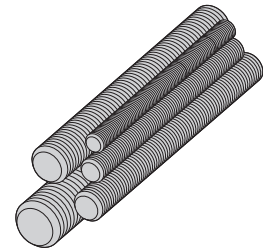

Part No.	Thread Size	Design Load (in tension)		Max. Torque		Wt./Ft.	
		Lbs.	kN	in.-Lbs.	N*m	Lbs.	kg
BFVATR 3/8 x 48"	3/8"-16	350	(1.55)	48	(5.4)	.08	(.04)
BFVATR 1/2 x 48"	1/2"-13	650	(2.89)	96	(10.8)	.13	(.06)
BFVATR 5/8 x 48"	5/8"-11	1000	(4.45)	192	(21.7)	.21	(.09)

BFVATRHN Threaded Rod Nuts

- ATR Nut is required with 3/8"-16 and 1/2"-13 ATR to provide additional thread engagement which is critical to ATR load carrying capacity.
- Material: Glass reinforced polyurethane

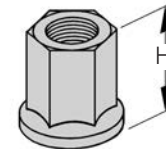

Part No.	Thread Size	H		Wt./C	
		in.	mm	Lbs.	kg
BFVATRHN 3/8	3/8"-16	3/4	(19)	.8	(.36)
BFVATRHN 1/2	1/2"-13	7/8	(22)	1.7	(.77)

BFVFW Flat Washers

- Material: PVC

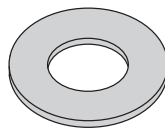

Part No.	Hole Size in.	Wt./C	
		Lbs.	kg
BFVFW 3/8	3/8	.5	(.22)
BFVFW 1/2	1/2	.5	(.22)
BFVFW 5/8	5/8	.5	(.22)
BFVFW 3/4	3/4	.5	(.22)
BFVFW 1	1	.5	(.22)

BFV655 Series Rod Couplings

- Material: Glass reinforced polyurethane



Part No.	Thread Size	Wt./C	
		Lbs.	kg
BFV655-3/8	3/8"-16	7.4	(3.35)
BFV655-1/2	1/2"-13	11.3	(5.12)
BFV655-5/8	5/8"-11	16.7	(7.57)

BFVSL Series Stop-Lock Kits

- Material: Glass Reinforced Polyurethane

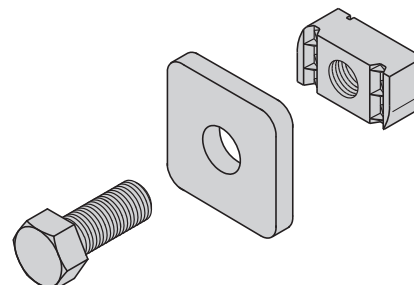

Part No.	Thread Size	Wt./C	
		Lbs.	kg
BFVSL-3/8	3/8"-16	7.4	(3.35)
BFVSL-1/2	1/2"-13	11.3	(5.12)

Reference page 224 for general fitting specifications.

BFV100 thru BFV300 Adjustable Pipe Clamps

- Completely Non-Metallic
- Adjustable to U.S. & Metric pipe diameters
- Fits OD Sizes 3/4" (19.0) to 3 1/2" (88.9)
- Easy To Install
- No special tools required
- Design Load Safety Factor of 3
- Material: Glass reinforced polyurethane
- Not recommended for vertical installation without additional Stop-Lock Kit. Kit includes one square washer, channel nut and hex head cap screw.

Order (Stop-Lock Kit on page 232) BFVSL-3/8 for 3/8"-16 hardware or BFVSL-1/2 for 1/2"-13 hardware.

Mount kit below clamp when used in vertical strut to prevent clamp slipping.

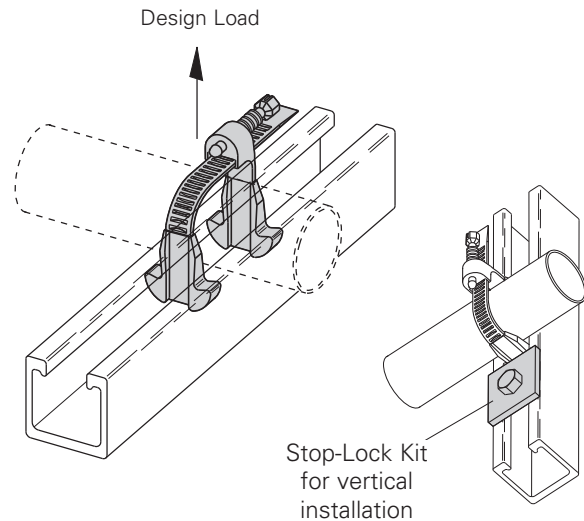

Part No.	Nominal Pipe Sizes		Pipe O.D. Range		Design Load		Max. Torque	
	in.	mm	in.	mm	Lbs.	kN	in.-Lbs.	N•m
BFV100	1/2 - 1 1/2	(15 - 40)	.75 - 1.90	(21.3 - 48.3)	135	(.60)	10	(1.13)
BFV200	1 1/2 - 2	(40 - 51)	1.90 - 2.37	(48.3 - 60.3)	135	(.60)	36	(4.07)
BFV300	2 1/2 - 3	(63 - 76)	2.87 - 3.50	(73.0 - 88.9)	145	(.64)	36	(4.07)

BFV2000 Series Non-Metallic Pipe Clamps

- For rigid and PVC conduit.
- Standard hardware includes slotted round head machine screw and square nut in 316 stainless steel
- Design Load Safety Factor of 3
- Material: Glass reinforced PPO
- Not recommended for vertical installation without additional Stop-Lock Kit. Kit includes one square washer, channel nut and hex head cap screw.
- Order (Stop-Lock Kit on page 232) BFVSL-3/8 for 3/8"-16 hardware or BFVSL-1/2 for 1/2"-13 hardware. Mount kit below clamp when used in vertical strut to prevent clamp slipping.
- If non-metallic hardware is required, add N to the part number.

Example: BFV2008N

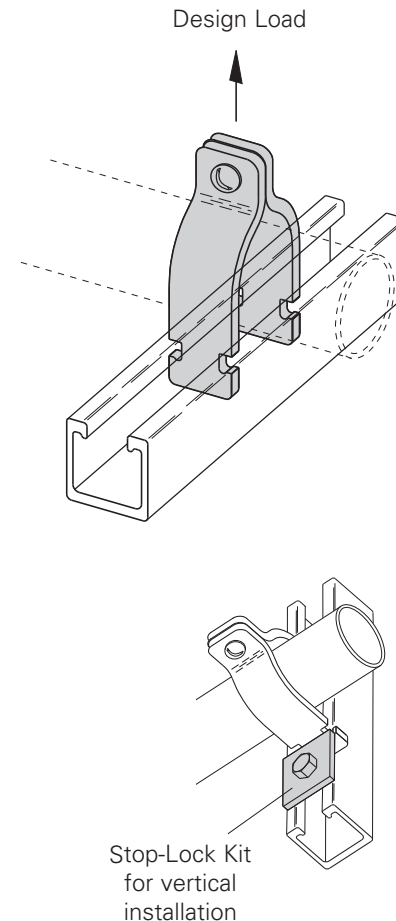

Part No.	Nominal Pipe Size		Design Load		Maximum Torque	
	in.	mm	Lbs.	kN	in.-Lbs.	N•m
BFV2008	1/2	(15)	300	(1.33)	10	(1.13)
BFV2009	3/4	(20)	300	(1.33)	10	(1.13)
BFV2010	1	(25)	300	(1.33)	10	(1.13)
BFV2011	1 1/4	(32)	300	(1.33)	10	(1.13)
BFV2012	1 1/2	(40)	300	(1.33)	10	(1.13)
BFV2013	2	(50)	300	(1.33)	10	(1.13)
BFV2014	2 1/2	(65)	300	(1.33)	10	(1.13)
BFV2015	3	(80)	300	(1.33)	10	(1.13)
BFV2016	3 1/2	(90)	300	(1.33)	10	(1.13)
BFV2017	4	(100)	300	(1.33)	10	(1.13)

Reference page 224 for general fitting specifications.

Fiberglass

BFP2400 Series 2-Hole Pipe Clamps

- Design Load Safety Factor of 3
- Material: Glass reinforced polyester

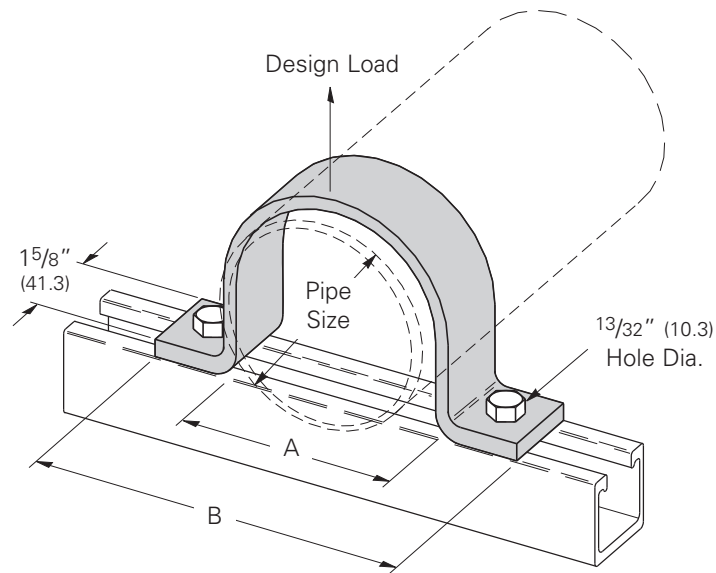

Part No.	Nominal Pipe Size		A		B		Design Load	
	in.	mm	in.	mm	in.	mm	Lbs.	kN
BFP2400-2	2	(50)	2 ³ / ₈	(60)	5 ¹ / ₂	(140)	115	(0.51)
BFP2400-3	3	(80)	3 ¹ / ₂	(89)	6 ³ / ₄	(171)	130	(0.58)
BFP2400-4	4	(100)	4 ¹ / ₂	(114)	7 ³ / ₄	(197)	150	(0.66)
BFP2400-6	6	(150)	6 ⁵ / ₈	(168)	10	(254)	150	(0.66)

BFV751 & BFV751J Beam Clamp

- Design Load Safety Factor of 3
- BFV751J (clip included) must be used when installed on tapered flange beams.
- Material: Glass reinforced polyurethane
- Setscrew material: Stainless Steel 316 ASTM F593 Group 2, S4

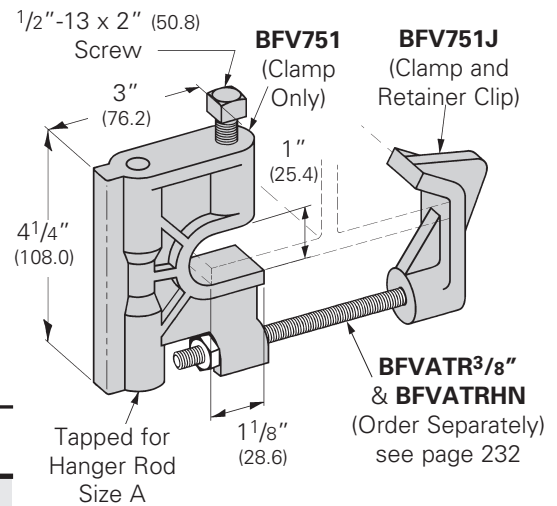

Part No.	For Hanger Rod Size A	Design Load		Torque	
		Lbs.	kN	ft-lbs	N-m
BFV751-3/8	3/8"-16	500	(2.22)	10	(13)
BFV751J-3/8	3/8"-16	500	(2.22)	10	(13)
BFV751-1/2	1/2"-13	500	(2.22)	10	(13)
BFV751J-1/2	1/2"-13	500	(2.22)	10	(13)
BFV751-5/8	5/8"-11	500	(2.22)	10	(13)
BFV751J-5/8	5/8"-11	500	(2.22)	10	(13)

Reference page 224 for general fitting specifications.

BFV755 Beam Clamp

- Design Load Safety Factor of 3
- Material: Glass reinforced polyurethane
- Setscrew material: Stainless Steel 316 ASTM F593 Group 2, S4

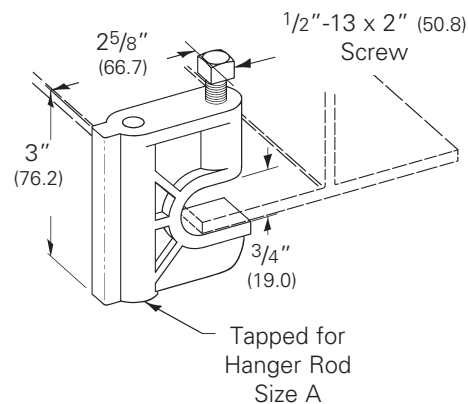

Part No.	For Hanger Rod Size A	Design Load Lbs. kN	Torque ft-lbs N-m
BFV755-3/8	3/8"-16	400 (1.78)	10 (13)
BFV755-1/2	1/2"-13	400 (1.78)	10 (13)

BFV3104 Series Clevis Hangers

- Design Load Safety Factor of 3 at 120°F (49°C).
- Insulation may be required at higher temperatures.
- Order hanger rod and nuts separately.
- Material: Glass reinforced polyurethane for BFV3104-1 thru BFV3104-6
- Material: Glass reinforced polyester & vinyl ester for BFV3104-8 thru BFV3104-12

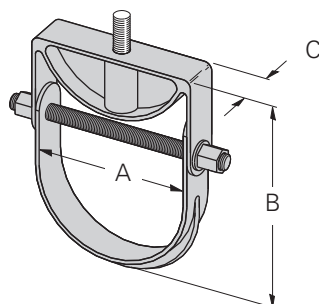

BFV3104-1 thru BFV3104-6

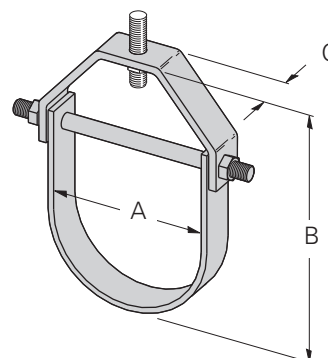

BFV3104-8 thru BFV3104-12

Part No.	Nominal Pipe Size		A		B		C		Hanger Rod Size	Design Load	
	in.	mm	in.	mm	in.	mm	in.	mm		Lbs.	kN
BFV3104-1	1	(50)	1 1/2	(38)	4 1/4	(108)	1 1/4	(32)	1/2"-13	670	(2.98)
BFV3104-1 1/2	1 1/2	(65)	2	(51)	5 1/8	(130)	1 1/4	(32)	1/2"-13	670	(2.98)
BFV3104-2	2	(50)	2 1/2	(63)	6 1/2	(165)	1 1/4	(32)	1/2"-13	730	(3.25)
BFV3104-2 1/2, 3, 4	2 1/2-4	(65-100)	5 1/8	(130)	10	(254)	1 1/2	(38)	1/2"-13	1150	(5.11)
BFV3104-6	6	(150)	6 3/4	(171)	12 5/16	(313)	2	(51)	1/2"-13	1170	(5.20)

Part No.	Nominal Pipe Size		A		B		C		Hanger Rod Size	Design Load	
	in.	mm	in.	mm	in.	mm	in.	mm		Lbs.	kN
BF*3104-8	8	(200)	9 1/4	(235)	16 5/8	(422)	3	(76)	5/8"-11	350	(1.55)
BF*3104-10	10	(250)	11 3/8	(289)	19 7/8	(505)	4	(101)	5/8"-11	450	(2.01)
BF*3104-12	12	(300)	13 1/2	(343)	22 3/8	(568)	5	(127)	5/8"-11	600	(2.69)

*Specify P for polyester or V for Vinyl ester.

Reference page 224 for general fitting specifications.

Fiberglass

BF*409 Series Brackets 6" (152mm) to 24" (609mm) Long

- Design Load Safety Factor of 3 based on uniform loading
- MH1 - From top of bracket to center of mounting hole
- MH2 - From bottom of bracket to center of mounting hole

Part No.	A		Design Load	
	in.	mm	Lbs.	kN
BF*409-6	10	(250)	1400	(6.22)
BF*409-9	13	(330)	1000	(4.45)
BF*409-12	16	(406)	800	(3.56)
BF*409-18	22	(559)	675	(3.00)
BF*409-24	28	(711)	450	(2.00)

* Insert P for Glass Reinforced Polyester Resin or V for Glass Reinforced Vinyl Ester Resin

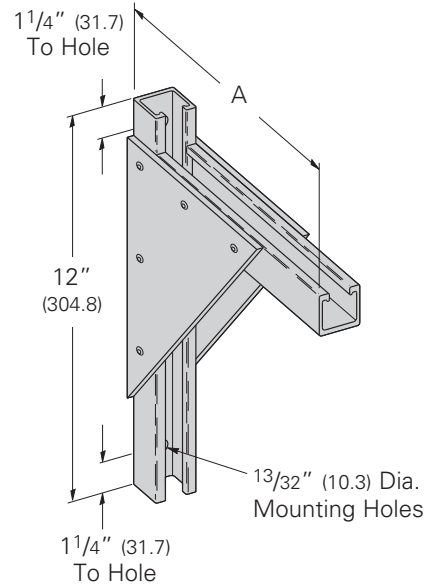

BF*494 Series Brackets 24" (609mm) to 36" (914mm) Long

- Design Load Safety Factor of 3 based on uniform loading
- MH1 - From top of bracket to center of mounting hole
- MH2 - From bottom of bracket to center of mounting hole
- Material: Glass reinforced vinyl ester or polyester

Part No.	A		B		Design Load	
	in.	mm	in.	mm	Lbs.	kN
BF*494-24	28	(711)	23	(584)	750	(3.33)
BF*494-30	34	(863)	26	(660)	750	(3.33)
BF*494-36	40	(1016)	29	(736)	750	(3.33)

* Insert P for glass reinforced polyester resin or V for glass reinforced vinyl ester resin

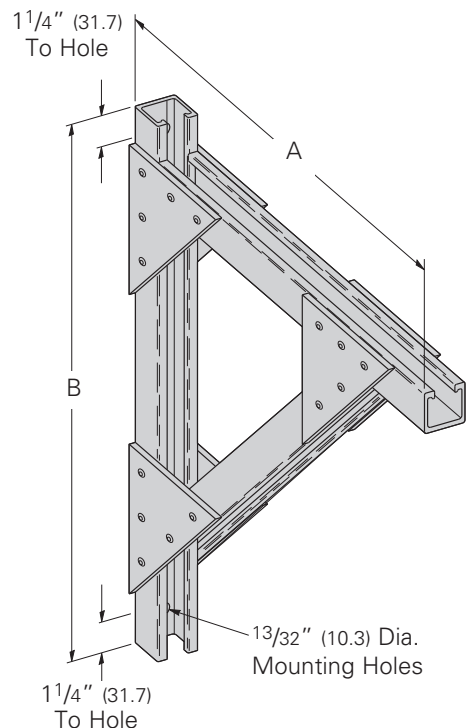

Reference page 224 for general fitting specifications.

BFV201 Square Washer for 3/8" bolt

- Material: Injection molded glass reinforced polyurethane

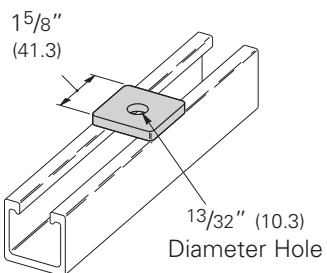

BFV202 Square Washer for 1/2" bolt

- Material: Injection molded glass reinforced polyurethane

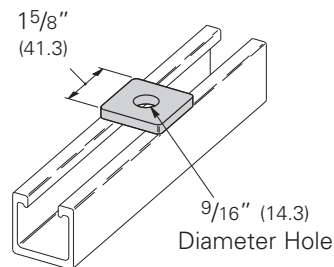

BFV340 Two Hole Flat Plate

- Material: Injection molded glass reinforced polyurethane

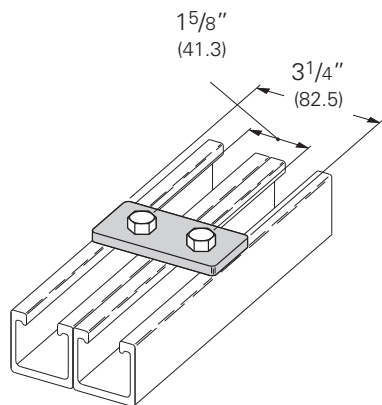

BFV129 Two Hole Splice Plate

- Material: Injection molded glass reinforced polyurethane

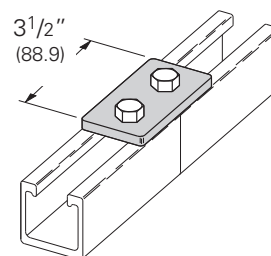

BFV141 Three Hole Flat Plate

- Material: Injection molded glass reinforced polyurethane

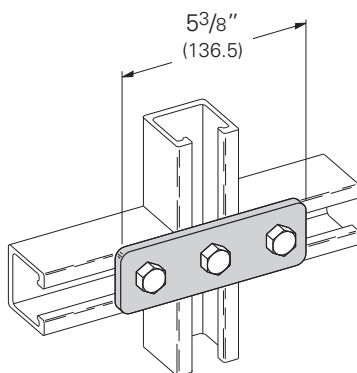

BFV557 Three Hole Flat Plate

- Material: Injection molded glass reinforced polyurethane

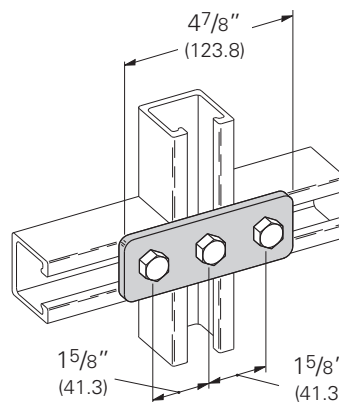

Reference page 224 for general fitting specifications.

Fiberglass

BFV341 Four Hole Splice Plate

- Material: Injection molded glass reinforced polyurethane

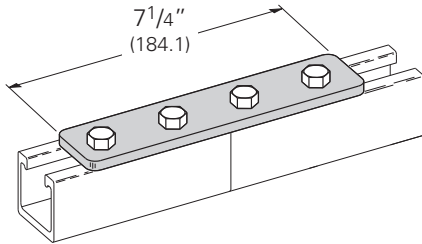

BFV342 Five Hole Flat Plate

- Material: Injection molded glass reinforced polyurethane

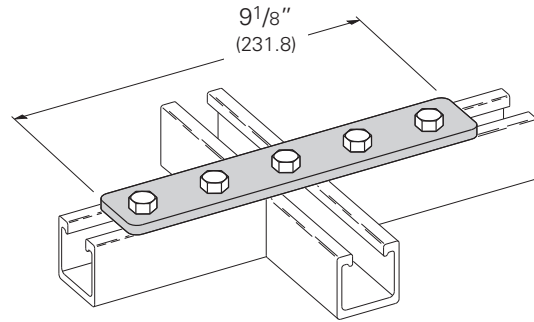

BFV140 Three Hole Flat Corner Plate

- Material: Injection molded glass reinforced polyurethane

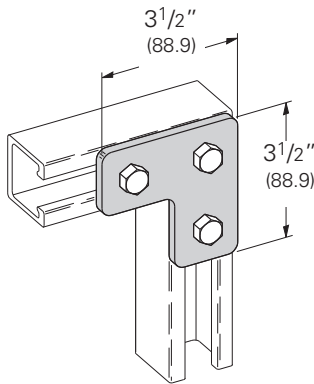

BFV143 Four Hole Flat Corner Plate

- Material: Injection molded glass reinforced polyurethane

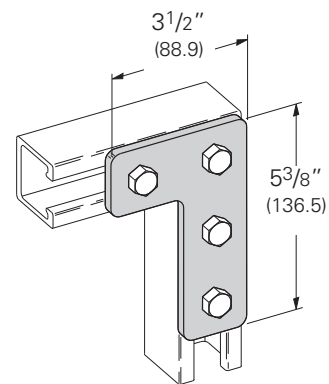

BFV132 Five Hole Flat Cross Plate

- Material: Injection molded glass reinforced polyurethane

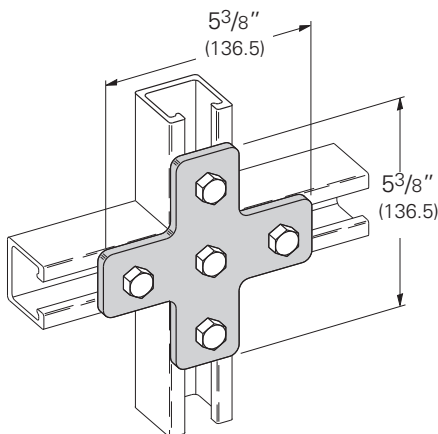

BFV133 Four Hole Flat Tee Plate

- Material: Injection molded glass reinforced polyurethane

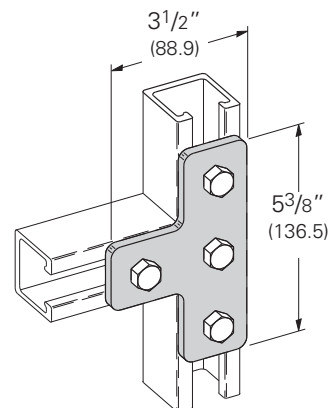

Reference page 224 for general fitting specifications.

BFV135
Three Hole Flat Gusset Corner Plate

- Material: Injection molded glass reinforced polyurethane

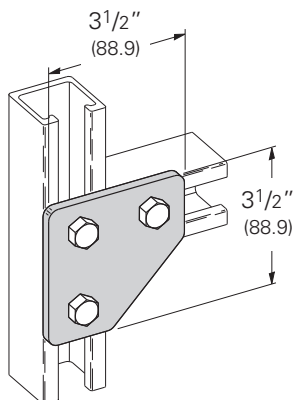

BFV142
Four Hole Flat Gusset Corner Plate

- Material: Injection molded glass reinforced polyurethane

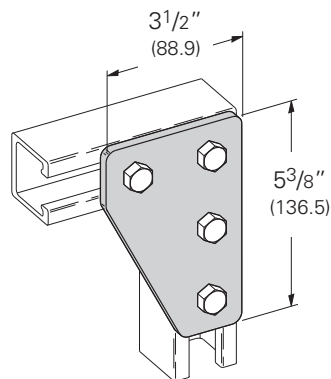

BFV337
Three Hole Flat Gusset Tee Plate

- Material: Injection molded glass reinforced polyurethane

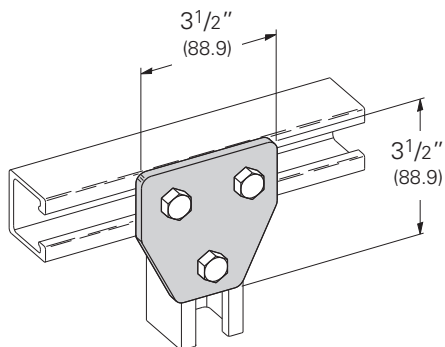

BFV136
Four Hole Flat Gusset Tee Plate

- Material: Injection molded glass reinforced polyurethane

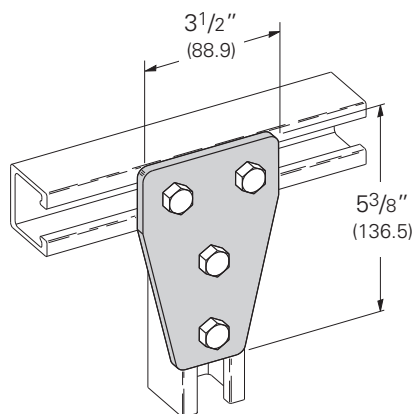

BFV532
Five Hole Flat Gusset Tee Plate

- Material: Injection molded glass reinforced polyurethane

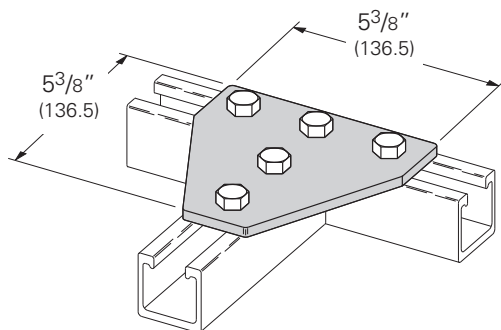

BFV334
Seven Hole Flat Gusset Cross Plate

- Material: Injection molded glass reinforced polyurethane

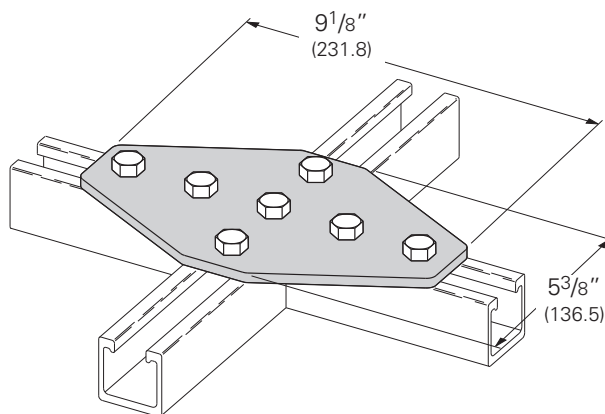

Reference page 224 for general fitting specifications.

Fiberglass

BFV101 Two Hole 90° Corner Angle

- Material: Injection molded glass reinforced polyurethane

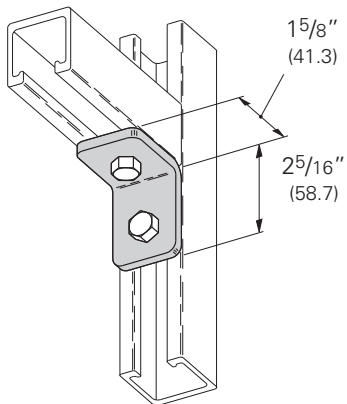

BFV103 Three Hole 90° Corner Angle

- Material: Injection molded glass reinforced polyurethane

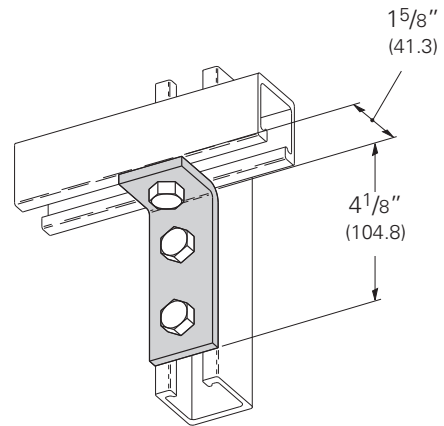

BFV104 Four Hole 90° Corner Angle

- Material: Injection molded glass reinforced polyurethane

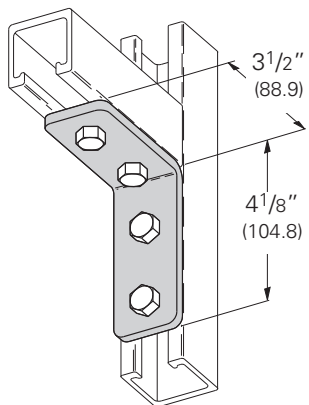

BFV118 Four Hole 90° Gussetted Shelf Angle

- Material: Injection molded glass reinforced polyurethane

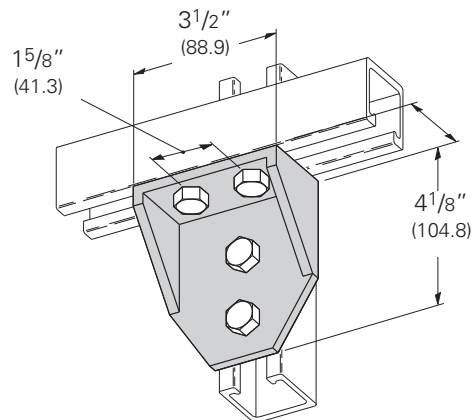

BFV558 Four Hole 90° Corner Angle

- Material: Injection molded glass reinforced polyurethane

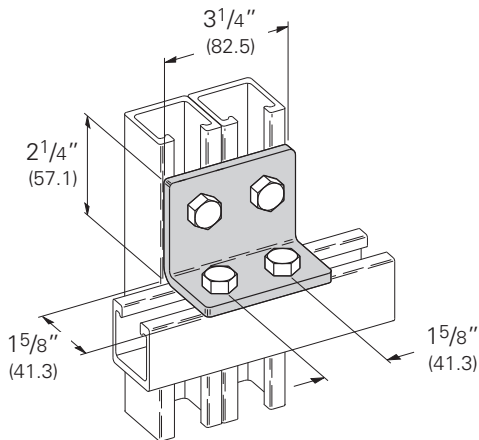

BFV371-2G Three Hole 90° Gussetted Corner Angle

- Material: Injection molded glass reinforced polyurethane

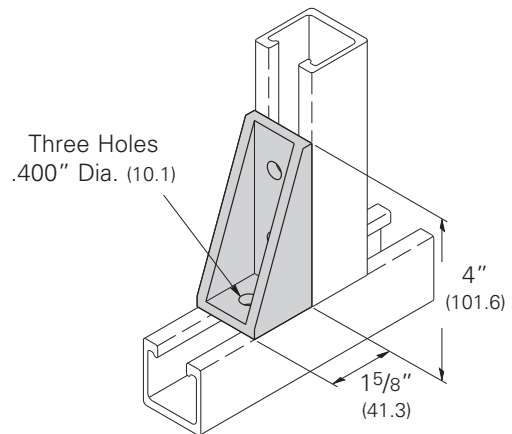

Reference page 224 for general fitting specifications.

BFV280SQ Post Base for BF*22

- Material: Glass reinforced polyurethane

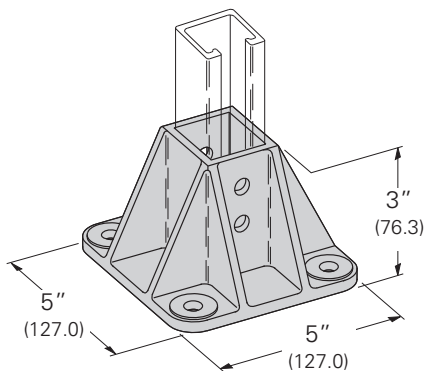

BFV281SQ Post Base for BF*22A

- Material: Glass reinforced polyurethane

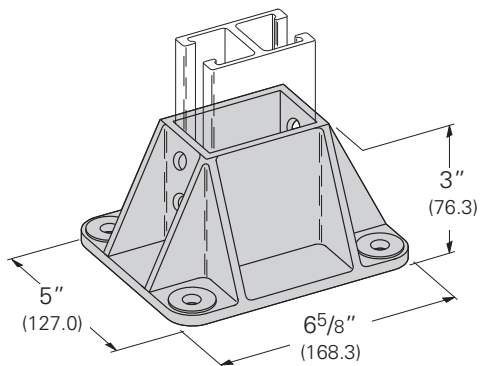

BFV650 Channel Spacer

- Spacer I.D. accommodates 3/8" rod or bolts.

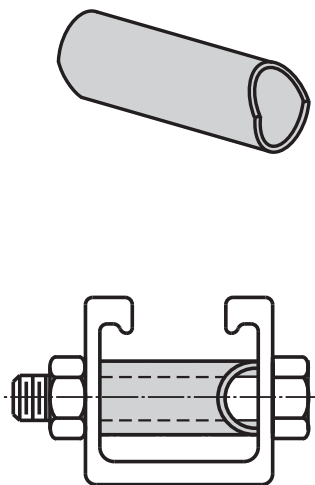

Used when attaching fittings to side walls of channel. This channel spacer prevents wall compression in heavy load conditions.

B217P Plastic Closure Strip

- Available in 10 Ft. (3.05 m) lengths.
- Material: PVC

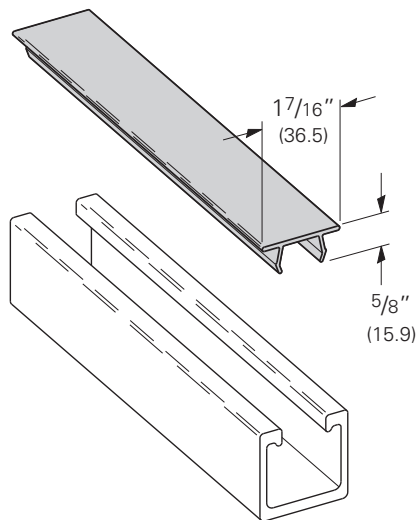

Reference page 224 for general fitting specifications.

Mini Channel & Fittings



Our mini channels and fittings provide for an economical method of supporting light load requirements on a strut system.

Channel

Channels are cold formed on our modern rolling mills from 18 Ga. (1.2 mm) low carbon steel strips plain steel (ASTM A1008 33,000 PSI min. yield) and pre-galvanized steel strips, (ASTM A653 33,000 PSI min. yield). A continuous slot with inturred lips provides the ability to make attachments at any point. Channel combinations are made with new state of the art, high-tech welding equipment.

Lengths

Standard lengths are 10' (3.05 m) and 20' (6.09 m) for B62 series, and 10' (3.05 m) for B72 series. Custom lengths are available.

Fittings

Mini fittings are formed from hot rolled pickled and oiled strip or sheet steel (ASTM A1011, HSLAS, Grade 50, Class1). The following dimensions apply to all fittings except as noted on the drawings:

Hole Size – $9/32''$ (7.14 mm) Dia.

Hole Spacing – $13/32''$ (10.3 mm) from end and $1\ 1/16''$ (27.0 mm) on center.

Width – $13/16''$ (20.6 mm)

Thickness – $1/8''$ (3.2 mm)

Materials & Finishes*

*Unless otherwise noted.

Finish Code	Finish	Specification
PLN	Plain	ASTM A1011, HSLAS, Grade 50, Class 1
ZN	Electro-Plated Zinc	ASTM B633 SC3 Type II
GRN	DURA-GREEN™	
GLV	Pre-Galvanized	ASTM A653 33,000 PSI min. yield
HDG	Hot-Dipped Galvanized	ASTM A123

Metric

Metric dimensions are shown in parentheses. Unless noted, all metric dimensions are in millimeters.

B62 Channel

- Thickness: 18 Ga. (1.2 mm)
- Standard lengths: 10' (3.05 m) & 20' (6.09 m)
- Standard finishes: Plain, DURA GREEN™, Pre-Galvanized
- Weight: .42 Lbs./Ft. (.62 kg/m)

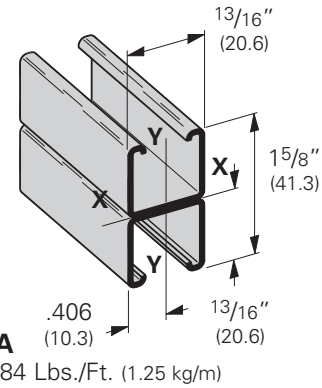
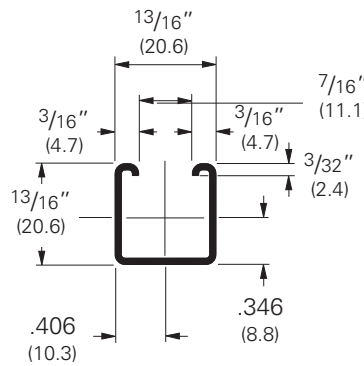
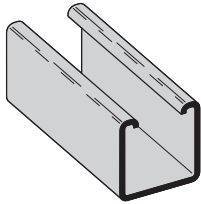

Section Properties

Channel	Weight lbs./ft. kg/m	Areas of Section sq. in. cm ²	X - X Axis				Y - Y Axis			
			Moment of Inertia (I) in. ⁴ cm ⁴	Section Modulus (S) in. ³ cm ³	Radius of Gyration (r) in. cm	Moment of Inertia (I) in. ⁴ cm ⁴	Section Modulus (S) in. ³ cm ³	Radius of Gyration (r) in. cm		
B62	.420 (.62)	.123 (.80)	.0103 (.43)	.0221 (.36)	.289 (.73)	.0134 (.56)	.0330 (.54)	.330 (.84)		
B62A	.839 (1.25)	.247 (1.59)	.0500 (2.08)	.0616 (1.01)	.450 (1.14)	.0269 (1.12)	.0663 (1.09)	.330 (.84)		

Calculations of section properties are based on metal thicknesses as determined by the AISI Cold-Formed Steel Design Manual.

Beam Loading

Beam Span In. mm	Channel Style	Uniform Load and Deflection				Uniform Load @ Deflection =			
		Lbs. kN		In. mm		1/240 Span		1/360 Span	
12 (305)	B62	364 (1.62)	.027 (.68)	364 (1.62)	364 (1.62)				
	B62A	420* (1.87)	.006 (.15)	420* (1.87)	420* (1.87)				
24 (609)	B62	182 (0.81)	.109 (2.77)	167 (0.74)	111 (0.49)				
	B62A	420* (1.87)	.051 (1.29)	420* (1.87)	420* (1.87)				
36 (914)	B62	121 (0.54)	.245 (6.22)	74 (0.33)	50 (0.22)				
	B62A	341 (1.51)	.141 (3.58)	341 (1.51)	242 (1.07)				
48 (1219)	B62	91 (0.40)	.436 (11.07)	42 (0.18)	28 (0.12)				
	B62A	256 (1.14)	.250 (6.35)	204 (0.91)	136 (0.60)				
60 (1524)	B62	73 (0.32)	.681 (17.30)	27 (0.12)	18 (0.08)				
	B62A	205 (0.91)	.391 (9.93)	131 (0.58)	87 (0.39)				
72 (1829)	B62	61 (0.27)	.981 (24.92)	19 (0.08)	12 (0.05)				
	B62A	170 (0.75)	.563 (14.30)	91 (0.40)	61 (0.27)				

Based on simple beam condition using an allowable design stress of 25,000 psi (172 MPa) in accordance with MFMA, with adequate lateral bracing (see page 12 for further explanation). Actual yield point of cold rolled steel is 42,000 psi. To determine concentrated load capacity at mid span, multiply uniform load by 0.5 and corresponding deflection by 0.8. *Failure determined by weld shear.

Column Loading

Unbraced Height In. mm	Channel Style	Max. Column Loading K = .80		Max. Column Loading (Loaded @ C.G.)							
		Loaded @ C.G.		Loaded @ Slot Face		K = .65		K = 1.0		K = 1.2	
		Lbs. kN	Lbs. kN	Lbs. kN	Lbs. kN	Lbs. kN	Lbs. kN	Lbs. kN	Lbs. kN		
12 (305)	B62	2052 (9.13)	820 (3.65)	2161 (9.61)	1890 (8.41)	1715 (7.63)					
	B62A	4666 (20.75)	1449 (6.44)	4710 (20.95)	4593 (20.43)	4503 (20.03)					
24 (609)	B62	1350 (6.00)	645 (2.87)	1624 (7.22)	1020 (4.54)	818 (3.64)					
	B62A	4275 (19.01)	1367 (6.08)	4453 (19.81)	3982 (17.71)	3624 (16.12)					
36 (914)	B62	818 (3.64)	471 (2.09)	1053 (4.68)	633 (2.81)	515 (2.29)					
	B62A	3624 (16.12)	847 (3.77)	4023 (17.89)	2965 (13.19)	2179 (9.69)					
48 (1219)	B62	589 (2.62)	369 (1.64)	745 (3.31)	456 (2.03)	365** (1.62)					
	B62A	2713 (12.06)	504 (2.24)	3421 (15.21)	1765 (7.85)	1225 (5.45)					
60 (1524)	B62	456 (2.03)	300 (1.33)	579 (2.57)	347** (1.54)	271** (1.20)					
	B62A	1765 (7.85)	323 (1.44)	2647 (11.77)	1129 (5.02)	784** (3.49)					
72 (1829)	B62	365** (1.62)	248 (1.10)	470 (2.09)	271** (1.20)	-					
	B62A	1225 (5.45)	224 (0.99)	1856 (8.25)	784** (3.49)	545** (2.42)					

**Where the slenderness ratio $\frac{KL}{r}$ exceeds 200, and K = end fixity factor, L = actual length and r = radius of gyration.

Reference page 242 for general fitting specifications.

B72 Channel

- Thickness: 18 Ga. (1.2 mm)
- Standard lengths: 10' (3.05 m) & 20' (6.09 m)
- Standard finishes: Plain, DURA GREEN™, Pre-Galvanized
- Weight: .29 Lbs./Ft. (.43 kg/m)

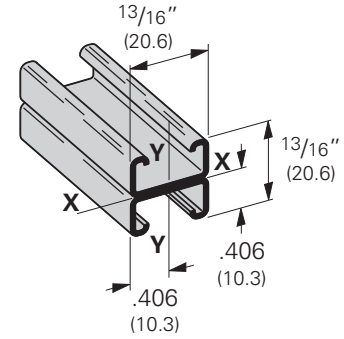
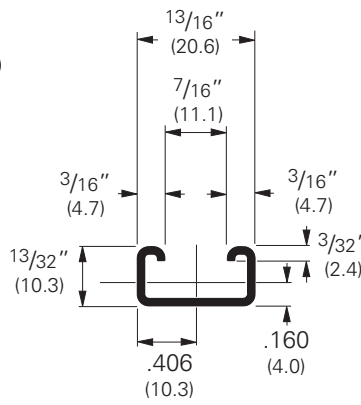
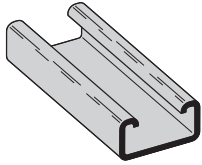

B72A
Wt. .58 Lbs./Ft. (.87 kg/m)

Section Properties

Channel	Weight lbs./ft. kg/m	Areas of Section sq. in. cm ²	X - X Axis				Y - Y Axis			
			Moment of Inertia (I) in. ⁴ cm ⁴	Section Modulus (S) in. ³ cm ³	Radius of Gyration (r) in. cm	Moment of Inertia (I) in. ⁴ cm ⁴	Section Modulus (S) in. ³ cm ³	Radius of Gyration (r) in. cm		
B72	.287 (.43)	.084 (.54)	.0018 (.07)	.0073 (.12)	.146 (.37)	.0077 (.32)	.0190 (.31)	.302 (.77)		
B72A	.574 (.85)	.169 (1.09)	.0078 (.32)	.0192 (.31)	.215 (.55)	.0155 (.65)	.0382 (.63)	.303 (.77)		

Calculations of section properties are based on metal thicknesses as determined by the AISI Cold-Formed Steel Design Manual.

Beam Loading

Beam Span In. mm	Channel Style	Uniform Load and Deflection				Uniform Load @ Deflection =			
		Lbs.	kN	In.	mm	1/240 Span	1/360 Span	Lbs.	kN
12 (305)	B72	116	(0.51)	.051	(1.29)	113	(0.50)	75	(0.32)
	B72A	210*	(0.93)	.020	(.51)	210*	(0.93)	210*	(0.93)
24 (609)	B72	58	(0.26)	.206	(5.23)	28	(0.12)	19	(0.08)
	B72A	159	(0.71)	.125	(3.17)	127	(0.56)	85	(0.38)
36 (914)	B72	39	(0.17)	.465	(11.81)	13	(0.06)	8	(0.03)
	B72A	106	(0.45)	.281	(7.14)	57	(0.25)	38	(0.17)
36 (1219)	B72	29	(0.13)	.827	(21.00)	7	(0.03)	5	(0.02)
	B72A	80	(0.35)	.500	(12.70)	32	(0.14)	21	(0.09)
60 (1524)	B72	23	(0.10)	1.292	(32.81)	5	(0.02)	3	(0.01)
	B72A	64	(0.28)	.782	(19.86)	20	(0.09)	14	(0.06)

Based on simple beam condition using an allowable design stress of 25,000 psi (172 MPa) in accordance with MFMA, with adequate lateral bracing (see page 12 for further explanation). Actual yield point of cold rolled steel is 42,000 psi. To determine concentrated load capacity at mid span, multiply uniform load by 0.5 and corresponding deflection by 0.8. *Failure determined by weld shear.

Column Loading

Unbraced Height In. mm	Channel Style	Max. Column Loading K = .80				Max. Column Loading (Loaded @ C.G.)					
		Loaded @ C.G.		Loaded @ Slot Face		K = .65		K = 1.0		K = 1.2	
		Lbs.	kN	Lbs.	kN	Lbs.	kN	Lbs.	kN	Lbs.	kN
12 (305)	B72	1598	(7.11)	539	(2.40)	1712	(7.61)	1410	(6.27)	1181	(5.25)
	B72A	3600	(16.01)	986	(4.38)	3700	(16.46)	3433	(15.27)	3229	(14.36)
24 (609)	B72	701	(3.12)	320	(1.42)	1050	(4.67)	450	(2.00)	313**	(1.39)
	B72A	2710	(12.05)	802	(3.57)	3113	(13.85)	2043	(9.09)	1421	(6.32)
36 (914)	B72	313**	(1.39)	188	(0.83)	473	(2.10)	201**	(0.89)	—	—
	B72A	1421	(6.32)	569	(2.53)	2135	(9.50)	909	(4.04)	631**	(2.81)
36 (1219)	B72	177**	(0.79)	122	(0.54)	267**	(1.19)	—	—	—	—
	B72A	799	(3.55)	404	(1.80)	1211	(5.39)	512**	(2.28)	355**	(1.58)
60 (1524)	B72	113**	(0.50)	85	(0.38)	171**	(0.76)	—	—	—	—
	B72A	512**	(2.28)	298	(1.32)	775	(3.45)	327**	(1.45)	—	—

**Where the slenderness ratio $\frac{KL}{r}$ exceeds 200, and K = end fixity factor, L = actual length and r = radius of gyration.

Reference page 242 for general fitting specifications.

Mini Channel Nuts & Fittings

Nuts for B62, B72 Channel

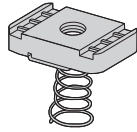

Spring Nut

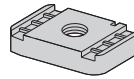

Nut Without Spring

B62		B72		Thread Size	Thickness		Wt./C	
With Spring	Without Spring	With Spring	Without Spring		In.	mm	Lbs.	kg
N621	N621WO	N7221	N621WO	#8-32	.150	(3.81)	1.0	(.45)
N622	N622WO	N7222	N622WO	#10-24	.150	(3.81)	1.0	(.45)
N627	N627WO	N7227	N627WO	#10-32	.150	(3.81)	1.0	(.45)
N624	N624WO	N7224	N624WO	1/4-20	.150	(3.81)	1.0	(.45)
BMM-3L	BMM-3	BMM-3S	BMM-3	M3.5 x 0.6	.150	(3.81)	1.0	(.45)
BMM-4L	BMM-4	BMM-4S	BMM-4	M4 x 0.7	.150	(3.81)	1.0	(.45)
BMM-5L	BMM-5	BMM-5S	BMM-5	M5 x 0.8	.150	(3.81)	1.0	(.45)
BMM-6L	BMM-6	BMM-6S	BMM-6	M6 x 1	.150	(3.81)	1.0	(.45)

Mini Fittings

B6202 Square Washer

- Standard finishes: ZN, GRN
- Wt./C 2 Lbs. (.9 kg)

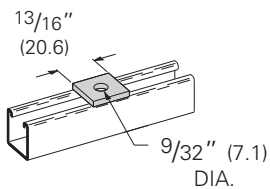

B6129 Two Hole Splice Plate

- Standard finishes: ZN, GRN
- Wt./C 5 Lbs. (2.2 kg)

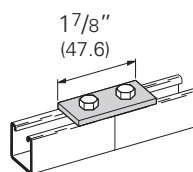

B6340 Two Hole Splice Plate

- Standard finishes: ZN, GRN
- Wt./C 5 Lbs. (2.2 kg)

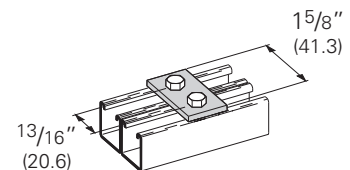

Reference page 242 for general fitting specifications.

Mini Fittings

B6141 Three Hole Splice Plate

- Standard finishes: ZN, GRN
- Wt./C 7 Lbs. (3.2 kg)

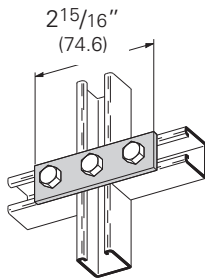

B600-62 Three Hole Flat Adapter Plate

- Standard finishes: ZN, GRN
- Wt./C 19 Lbs. (8.6 kg)

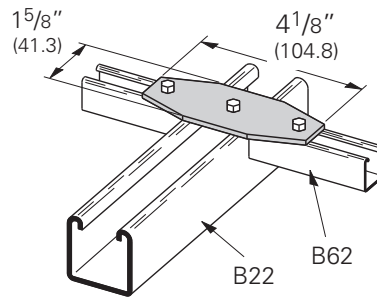

B6557 Three Hole Splice Plate

- Standard finishes: ZN, GRN
- Wt./C 7 Lbs. (3.2 kg)

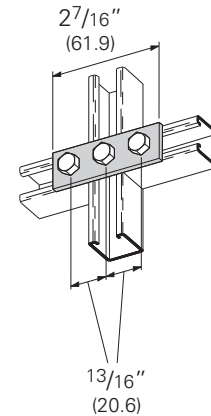

B6341 Four Hole Splice Plate

- Standard finishes: ZN, GRN
- Wt./C 11 Lbs. (5.0 kg)

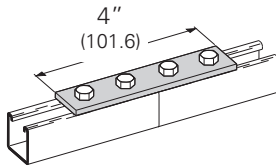

B6138 Two Hole Swivel Plate

- Standard finishes: ZN, GRN
- Wt./C 7 Lbs. (3.2 kg)

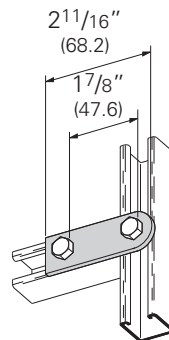

B6139 Three Hole Swivel Plate

- Standard finishes: ZN, GRN
- Wt./C 10 Lbs. (4.5 kg)

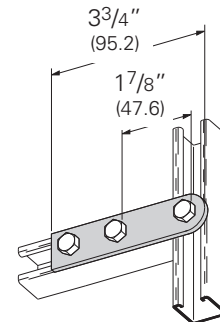

B6504 Four Hole Splice Plate

- Standard finishes: ZN, GRN
- Wt./C 10 Lbs. (4.5 kg)

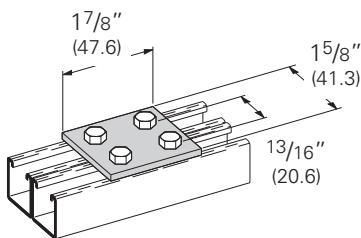

B6140 Three Hole Corner Plate

- Standard finishes: ZN, GRN
- Wt./C 8 Lbs. (3.6 kg)

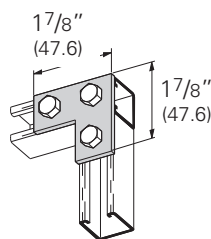

B6143 Four Hole Corner Plate

- Standard finishes: ZN, GRN
- Wt./C 11 Lbs. (5.0 kg)

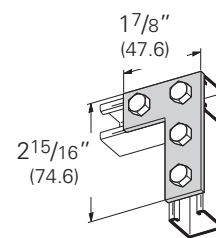

Reference page 242 for general fitting specifications.

B6133
Four Hole Tee Plate

- Standard finishes: ZN, GRN
- Wt./C 11 Lbs. (5.0 kg)

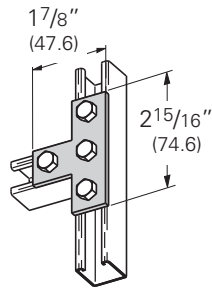

B6132
Five Hole Cross Plate

- Standard finishes: ZN, GRN
- Wt./C 13 Lbs. (5.9 kg)

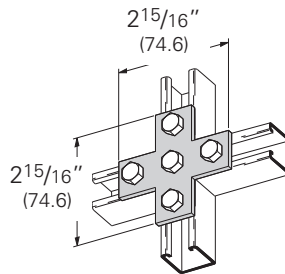

B6135
Three Hole Corner Gusset Plate

- Standard finishes: ZN, GRN
- Wt./C 9 Lbs. (4.1 kg)

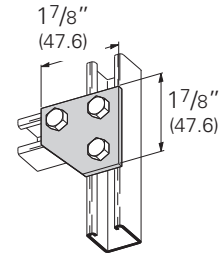

B6142
Four Hole Corner Gusset Plate

- Standard finishes: ZN, GRN
- Wt./C 15 Lbs. (6.8 kg)

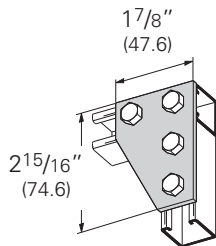

B6337
Three Hole Tee Gusset Plate

- Standard finishes: ZN, GRN
- Wt./C 10 Lbs. (4.5 kg)

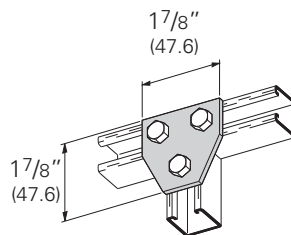

B6136
Four Hole Tee Gusset Plate

- Standard finishes: ZN, GRN
- Wt./C 15 Lbs. (6.8 kg)

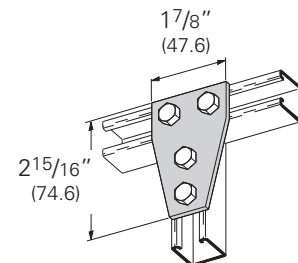

B6532
Five Hole Tee Gusset Plate

- Standard finishes: ZN, GRN
- Wt./C 22 Lbs. (10.0 kg)

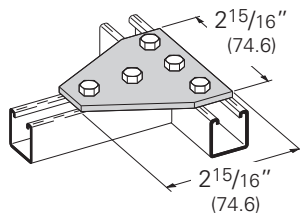

B6101
Two Hole Corner Angle

- Standard finishes: ZN, GRN
- Wt./C 5 Lbs. (2.2 kg)

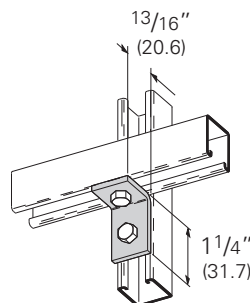

B6230
Two Hole Corner Angle

- Standard finishes: ZN, GRN
- Wt./C 5 Lbs. (2.2 kg)

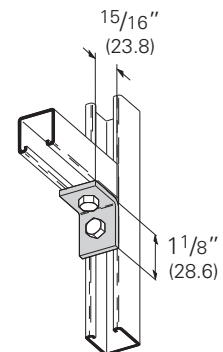

Reference page 242 for general fitting specifications.

Mini Fittings

B6102 Three Hole Corner Angle

- Standard finishes: ZN, GRN
- Wt./C 8 Lbs. (3.6 kg)

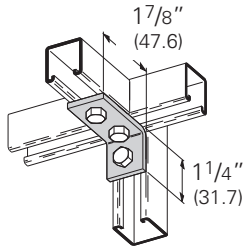

B6103 Three Hole Corner Angle

- Standard finishes: ZN, GRN
- Wt./C 8 Lbs. (3.6 kg)

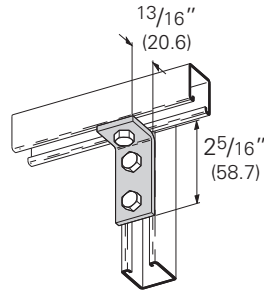

B6232 Three Hole Corner Angle

- Standard finishes: ZN, GRN
- Wt./C 7 Lbs. (3.2 kg)

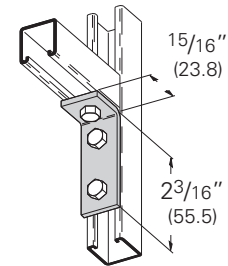

B6374 Three Hole Corner Angle

- Standard finishes: ZN, GRN
- Wt./C 7 Lbs. (3.2 kg)

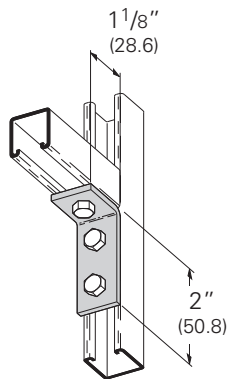

B6104 Four Hole Corner Angle

- Standard finishes: ZN, GRN
- Wt./C 10 Lbs. (4.5 kg)

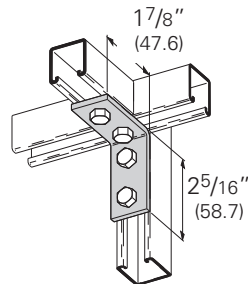

B6558 Four Hole Corner Angle

- Standard finishes: ZN, GRN
- Wt./C 10 Lbs. (4.5 kg)

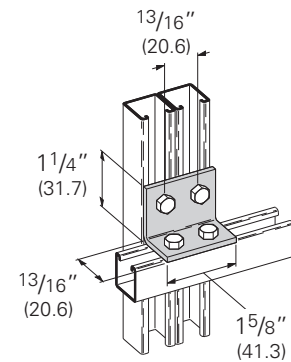

B6357 Four Hole Offset Bent Tee

- Standard finishes: ZN, GRN
- Wt./C 11 Lbs. (5.0 kg)

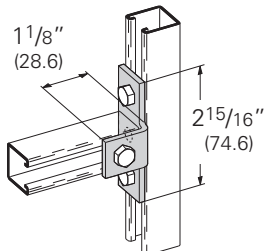

B6239 Five Hole Offset Bent Tee

- Standard finishes: ZN, GRN
- Wt./C 14 Lbs. (6.3 kg)

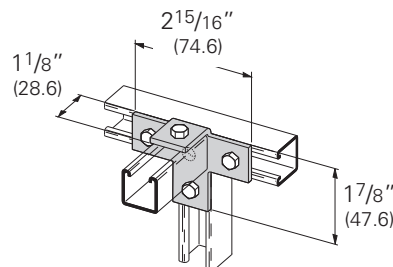

B6144R & L Four Hole Shelf Bracket

- Standard finishes: ZN, GRN
- Wt./C 19 Lbs. (8.6 kg)

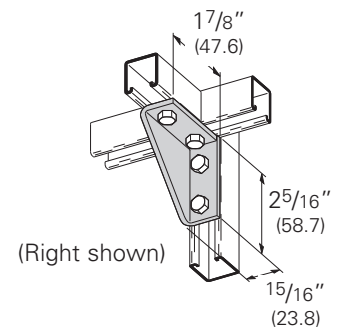

Reference page 242 for general fitting specifications.

B6134R & L Four Hole Corner Gusset

- Standard finishes: ZN, GRN
- Wt./C 15 Lbs. (6.8 kg)

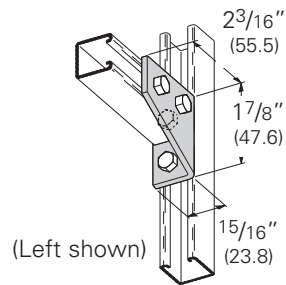

B6234R & L Four Hole Corner Gusset

- Standard finishes: ZN, GRN
- Wt./C 15 Lbs. (6.8 kg)

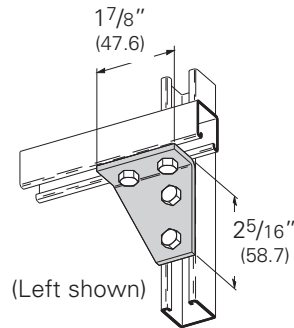

B6118 Four Hole Gussetted Shelf Angle

- Standard finishes: ZN, GRN
- Wt./C 15 Lbs. (6.8 kg)

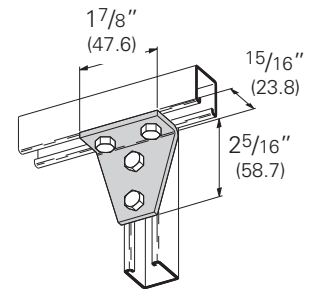

B6533 Five Hole Gussetted Shelf Angle

- Standard finishes: ZN, GRN
- Wt./C 22 Lbs. (10.0 kg)

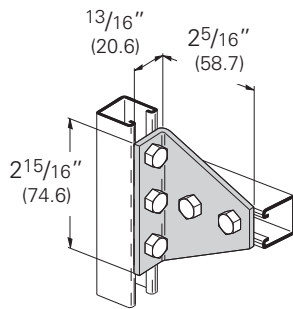

B6126 Four Hole Gussetted Three Way Shelf Angle

- Standard finishes: ZN, GRN
- Wt./C 15 Lbs. (6.8 kg)

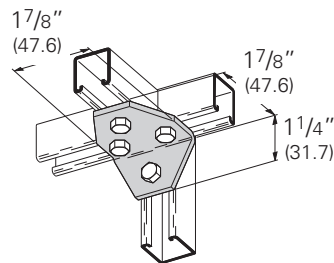

B6127 Five Hole Gussetted Three Way Shelf Angle

- Standard finishes: ZN, GRN
- Wt./C 18 Lbs. (8.1 kg)

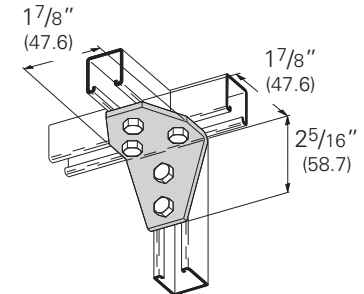

B6112 Four Hole Adjustable Corner Angle

- Standard finishes: ZN, GRN
- Wt./C 32Lbs. (14.5 kg)

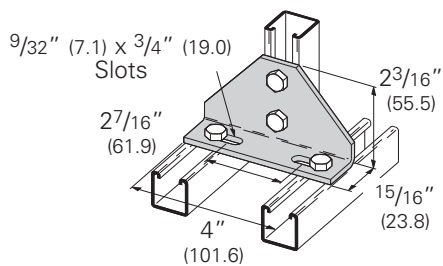

B589-62 Two Hole 90° Adapter Angle

- Standard finishes: ZN, GRN
- Wt./C 11 Lbs. (5.0 kg)

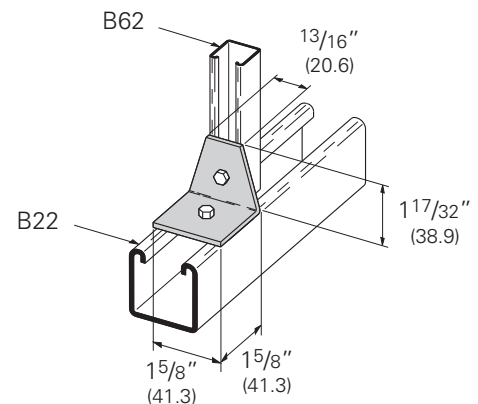

Reference page 242 for general fitting specifications.

Mini Fittings

B6147-B6152 Two Hole Open Angle

- Standard finishes: ZN, GRN

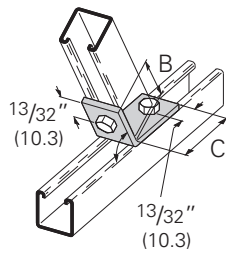

Part No.	A	B		C		Wt./C	
		In.	mm	In.	mm	Lbs.	kg
B6147	82 ¹ / ₂ °	2 ¹ / ₃₂ "	(51.6)	2 ⁷ / ₃₂ "	(21.4)	8.0	(3.6)
B6148	75°	2 ¹ / ₃₂ "	(51.6)	2 ⁷ / ₃₂ "	(21.4)		
B6149	67 ¹ / ₂ °	2"	(50.8)	7 ⁷ / ₈ "	(22.2)		
B6150	60°	1 ³¹ / ₃₂ "	(50.0)	1 ⁵ / ₁₆ "	(23.8)		
B6151	52 ¹ / ₂ °	1 ⁷ / ₈ "	(47.6)	1 ¹ / ₁₆ "	(27.0)		
B6152	37 ¹ / ₂ °	2"	(50.8)	2 ⁹ / ₃₂ "	(23.0)		

B6154 Two Hole Open Angle

- Standard finishes: ZN, GRN
- Wt./C 8 Lbs. (3.6 kg)

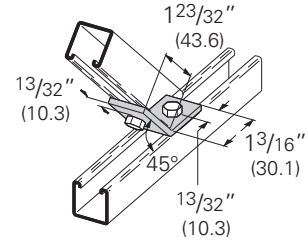

B6162-B6165 Two Hole Open Angle

- Standard finishes: ZN, GRN

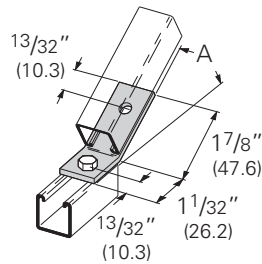

Part No.	A	Wt./C	
		Lbs.	kg
B6162	30°	8.0	(3.6)
B6163	22 ¹ / ₂ °		
B6164	15°		
B6165	7 ¹ / ₂ °		

B6155 Two Hole Closed Angle

- Standard finishes: ZN, GRN
- Wt./C 8 Lbs. (3.6 kg)

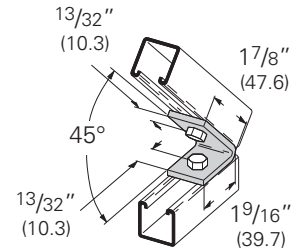

B6156-B6161 Two Hole Closed Angle

- Standard finishes: ZN, GRN

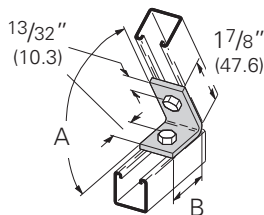

Part No.	A	B		Wt./C	
		In.	mm	Lbs.	kg
B6156	82 ¹ / ₂ °	1 ⁹ / ₃₂ "	(32.5)	8.0	(3.6)
B6157	75°	1 ⁵ / ₁₆ "	(33.3)		
B6158	67 ¹ / ₂ °	1 ³ / ₈ "	(34.9)		
B6159	60°	1 ¹³ / ₃₂ "	(35.7)		
B6160	52 ¹ / ₂ °	1 ¹⁵ / ₃₂ "	(37.3)		
B6161	37 ¹ / ₂ °	1 ²¹ / ₃₂ "	(42.0)		

Reference page 242 for general fitting specifications.

B601-62 Two Hole 45° Adapter Angle

- Standard finishes: ZN, GRN
- Wt./C 14 Lbs. (6.3 kg)

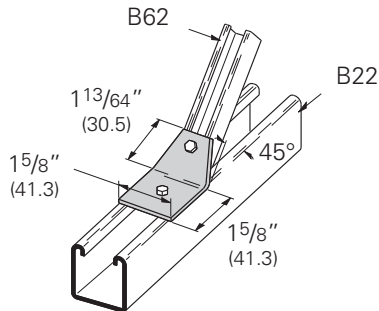

B6167 Four Hole Splice Clevis for B72

- Standard finishes: ZN, GRN
- Wt./C 24 Lbs. (10.9 kg)

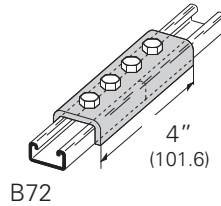

B6172 Four Hole Splice Clevis for B62

- Standard finishes: ZN, GRN
- Wt./C 36 Lbs. (16.3 kg)

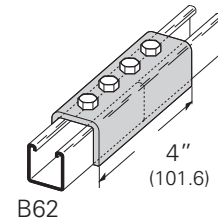

B7116 Three Hole U-Support

- Standard finishes: ZN, GRN
- Wt./C 10 Lbs. (4.5 kg)

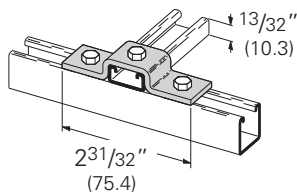

B6107 Three Hole U-Support

- Standard finishes: ZN, GRN
- Wt./C 12 Lbs. (5.4 kg)

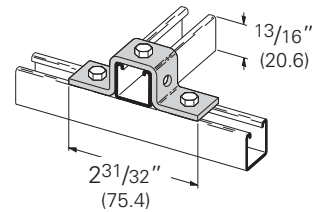

B6107-62A Three Hole U-Support

- Standard finishes: ZN, GRN
- Wt./C 16 Lbs. (7.2 kg)

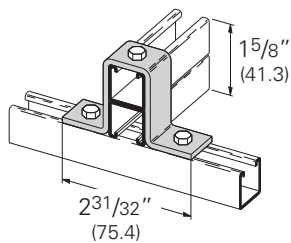

B6594 Five Hole U-Support

- Standard finishes: ZN, GRN
- Wt./C 13 Lbs. (5.9 kg)

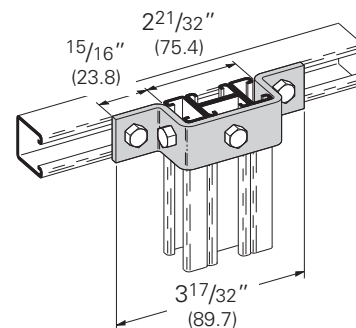

Reference page 242 for general fitting specifications.

Mini Fittings

B6173 Four Hole Clevis

- Standard finishes: ZN, GRN
- Wt./C 9 Lbs. (4.1 kg)

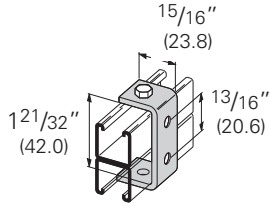

B6526 Two Hole Offset Z-Support

- Standard finishes: ZN, GRN
- Wt./C 5 Lbs. (2.2 kg)

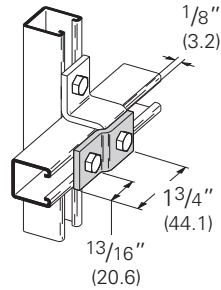

B6105 Two Hole Offset Z-Support for B62

- Standard finishes: ZN, GRN
- Wt./C 7 Lbs. (3.2 kg)

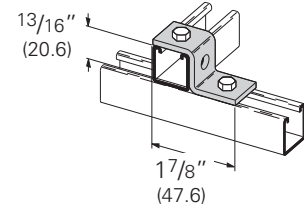

B7105 Two Hole Offset Z-Support for B72

- Standard finishes: ZN, GRN
- Wt./C 7 Lbs. (3.2 kg)

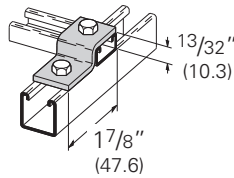

B6110 Two Hole Offset Z-Support for B62A

- Standard finishes: ZN, GRN
- Wt./C 9 Lbs. (4.1 kg)

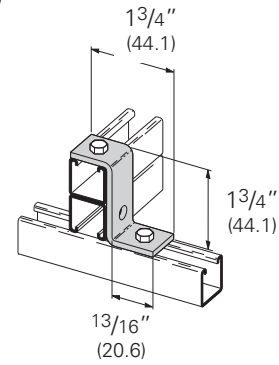

B6108 Two Hole Offset Z-Support

- Standard finishes: ZN, GRN
- Wt./C 7 Lbs. (3.2 kg)

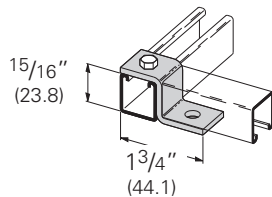

B598-62 Two Hole Z-Adapter Plate

- Standard finishes: ZN, GRN
- Wt./C 28 Lbs. (12.7 kg)

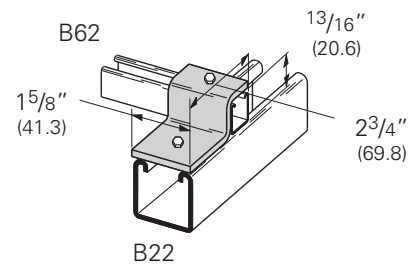

Reference page 242 for general fitting specifications.

B6205 End Cap for B62

- Material: ASTM A1008 SS Gr. 33 Type 1
- Standard finishes: ZN, GRN
- Wt./C 3 Lbs. (1.3 kg)

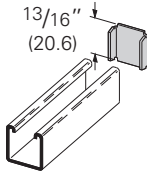

B7205 End Cap for B72

- Material: ASTM A1008 SS Gr. 33 Type 1
- Standard finishes: ZN, GRN
- Wt./C 1 Lb. (.4 kg)

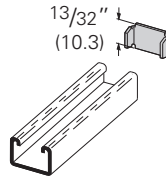

B6211 Z-Beam Clamp

- 5/16"-18 Setscrew included
- 13/16" (20.6) Max. Flange Thickness
- Material: ASTM A36
- Standard finishes: ZN, GRN
- Wt./C 13 Lbs. (5.9 kg)

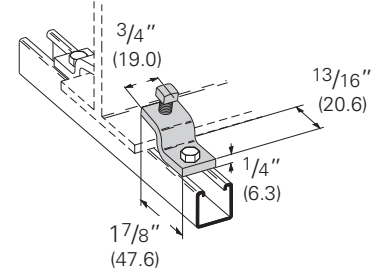

B6409-6, 9 Bracket

- Safety Factor of 2
- Uniform Design Load 40 Lbs. (.18 kN)
- Standard finishes: ZN, GRN

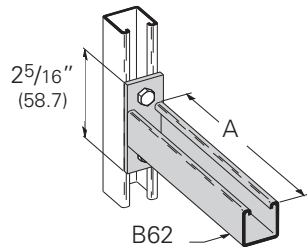

Part No.	A		Wt./C	
	In.	mm	Lbs.	kg
B6409-6	6"	(152.4)	28.0	(12.7)
B6409-9	9"	(228.6)	35.0	(15.8)

B2350-B2355 One Hole Double Tubing Strap

- Material: ASTM A1008 SS Gr. 33 Type 1
- Standard finishes: ZN, GRN

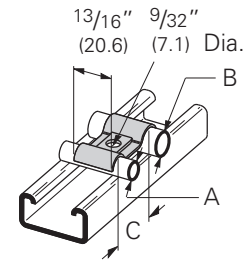

Part No.	O.D. Size A		O.D. Size B		C		Wt./C	
	In.	mm	In.	mm	In.	mm	Lbs.	kg
B2350	1/4"	(6.3)	1/4"	(6.3)	3/4"	(19.0)	1.2	(.5)
B2351	3/8"	(9.5)	3/8"	(9.5)	1"	(25.4)	2.0	(.9)
B2352	1/2"	(12.7)	1/2"	(12.7)	1 1/4"	(31.7)	2.9	(1.3)
B2353	1/4"	(6.3)	3/8"	(9.5)	7/8"	(22.2)	1.6	(.7)
B2354	1/4"	(6.3)	1/2"	(12.7)	1"	(25.4)	2.1	(.9)
B2355	3/8"	(9.5)	1/2"	(12.7)	1 1/8"	(28.6)	2.5	(1.1)

B2308-B2315 One Hole Tubing Strap

- Material: Sizes 1/4" - 1/2", ASTM A611 Gr. C 5/8" - 1", ASTM A1008 SS Gr. 33 Type 1
- Standard finishes: ZN, GRN

Part No.	O.D. Size A		B		C		Wt./C	
	In.	mm	In.	mm	In.	mm	Lbs.	kg
B2308	1/4"	(6.3)	1 1/32"	(26.2)	.048	(1.2)	1.2	(.5)
B2309	5/16"	(7.9)	1 3/32"	(27.8)	.048	(1.2)	1.4	(.6)
B2310	3/8"	(9.5)	1 3/16"	(30.1)	.048	(1.2)	1.6	(.7)
B2311	1/2"	(12.7)	1 21/64"	(33.7)	.048	(1.2)	1.9	(.8)
B2312	5/8"	(15.9)	1 25/64"	(35.3)	.062	(1.6)	2.7	(1.2)
B2313	3/4"	(19.0)	1 39/64"	(40.9)	.075	(1.9)	4.3	(1.9)
B2314	7/8"	(22.2)	1 51/64"	(45.6)	.075	(1.9)	4.9	(2.2)
B2315	1"	(25.4)	2 1/32"	(51.6)	.075	(1.9)	5.2	(2.3)

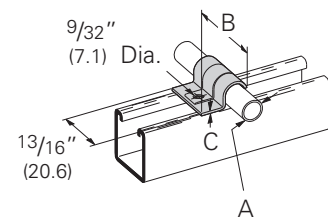

Reference page 242 for general fitting specifications.

Continuous Concrete Inserts



Continuous slot concrete inserts are designed to provide a pre-set support system cast in concrete ceilings, walls, and floors to allow flexibility of attachment at any point along the channel. This provides an excellent support system for pipe, conduit, and cable trays.

Continuous concrete inserts, manufactured from our standard channels, have formed anchors spaced on 4 inch (101.6 mm) centers. The $\frac{3}{16}$ " (4.8 mm) nail-holes are provided for securing the inserts to the forms.

Available in lengths from 3 inches (7.62 cm) to 240 inches (609.6 cm), concrete inserts are shipped complete with end caps and styrofoam filler strips which prevent seepage of concrete into the insert. Styrofoam is easily removed by pulling the convenient pull-tab.

Materials & Finishes*

*Unless otherwise noted.

Finish Code	Finish	Specification
PLN	Plain	ASTM A1011 33,000 PSI min. yield
GRN	DURA GREEN™	
ZN	Electro-Plated Zinc	ASTM B633 SC1 Type III
GALV	Pre-Galvanized	ASTM A653 33,000 PSI min. yield
HDG	Hot-Dipped Galvanized	ASTM A123
SS4	Stainless Steel Type 304	ASTM A240
SS6	Stainless Steel Type 316	ASTM A240

Spot Inserts

Spot inserts provide for economical single attachment points with full flexibility of fastener sizing, but with limited adjustment. These products are made from steel strips in accordance with ASTM A1011, 33,000 PSI min. yield. Standard finish is electro-plated zinc (ASTM B633).

Special Concrete Inserts

Pre-stressed inserts, inserts with studs welded to the back of the channel, and other types of special inserts are available.

Test Data

Independent Testing Laboratory test data available upon request.

Metric

Metric dimensions are shown in parentheses. Unless noted, all metric dimensions are in millimeters.

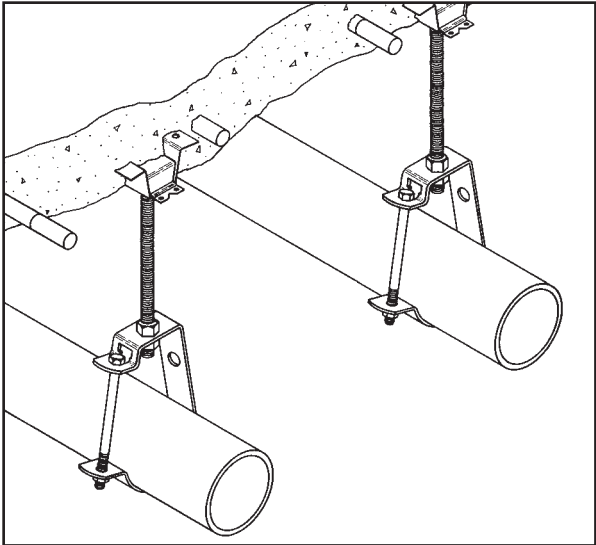
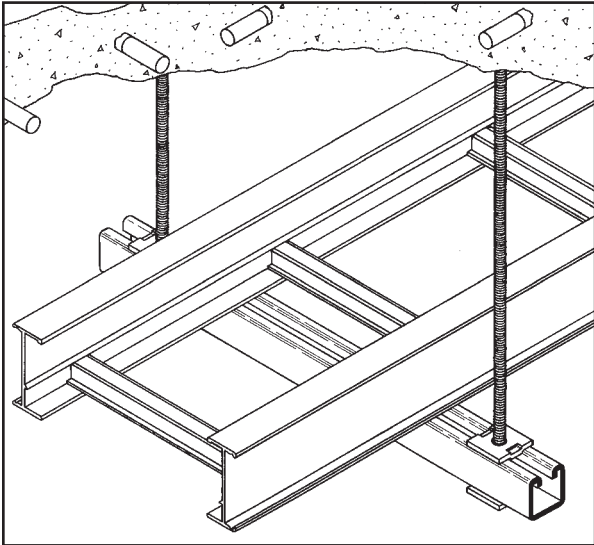

Continuous concrete inserts, installed in the ceiling, can be used to support trapeze hangers, suspended pipe racks, cable trays and single or multiple pipe hangers.

When installed in walls, continuous concrete inserts can be used as a support for tunnel stanchions, equipment braces, brackets and pipe racks.

Use spot inserts for single pipe-support or trapeze type hangers. Spot Inserts offer full flexibility of rod and fastener sizings.

Our channel can be attached to continuous concrete inserts in walls or ceilings. Channel can also be attached to concrete walls and floors with expansion anchors.

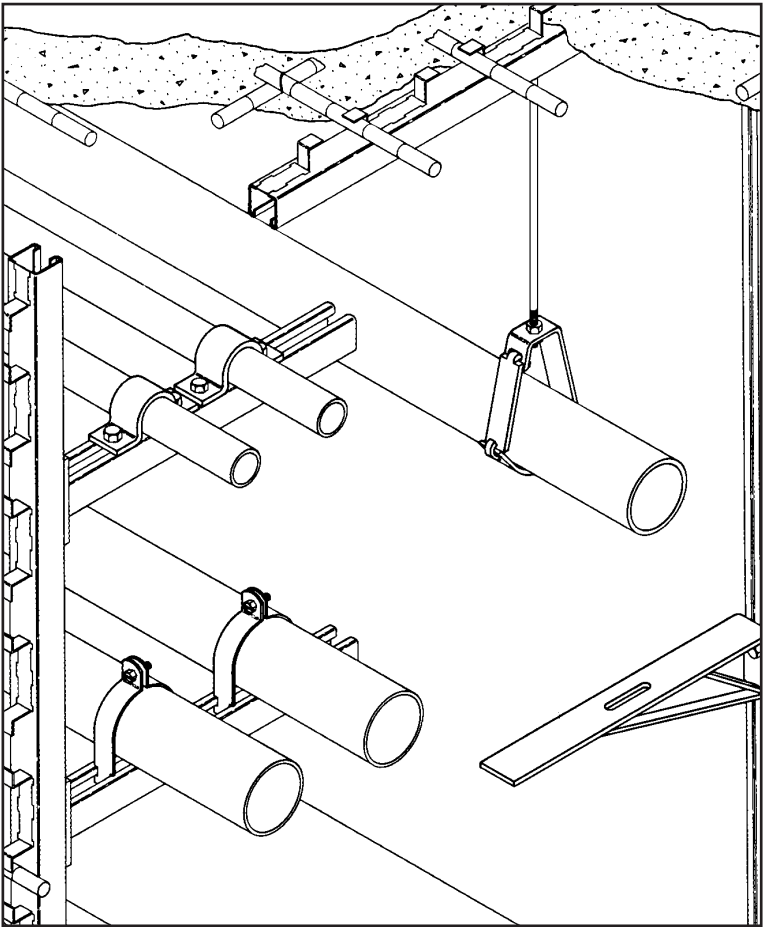

Concrete Inserts

Reference page 254 for general fitting and standard finish specifications.

Continuous Concrete Inserts

B22I Continuous Concrete Insert

- Design Load for B22-I-12 thru B22-I-240 is 2,000 lbs. (8.89 kN) per foot of concrete insert length with safety factor of 3 in 3000 psi concrete.
- Loads concentrated within the last 2 inches (50.8 mm) of concrete inserts 8" (203.2 mm) and longer should not exceed 1,000 lbs. (4.45kN).
- Concrete insert should be secured to the forms on 16" (406.4 mm) to 24" (609.6 mm) intervals.
- B22-I continuous concrete inserts are made from B22 channel. Use channel nuts designed for use in B22 channel.
- B22-I concrete inserts are supplied with styrofoam fillers. B3322 end caps are furnished with inserts through 8" (203.2 mm) long, and B205 end caps are furnished with inserts 12" (304.8 mm) and longer.
- Material: Plain Steel ASTM A1011 33,000 PSI min. yield or Pre-Galvanized Steel ASTM A653SS 33,000 PSI min. yield.
- Finish: Plain, DURA GREEN™, Pre-Galv, HDG

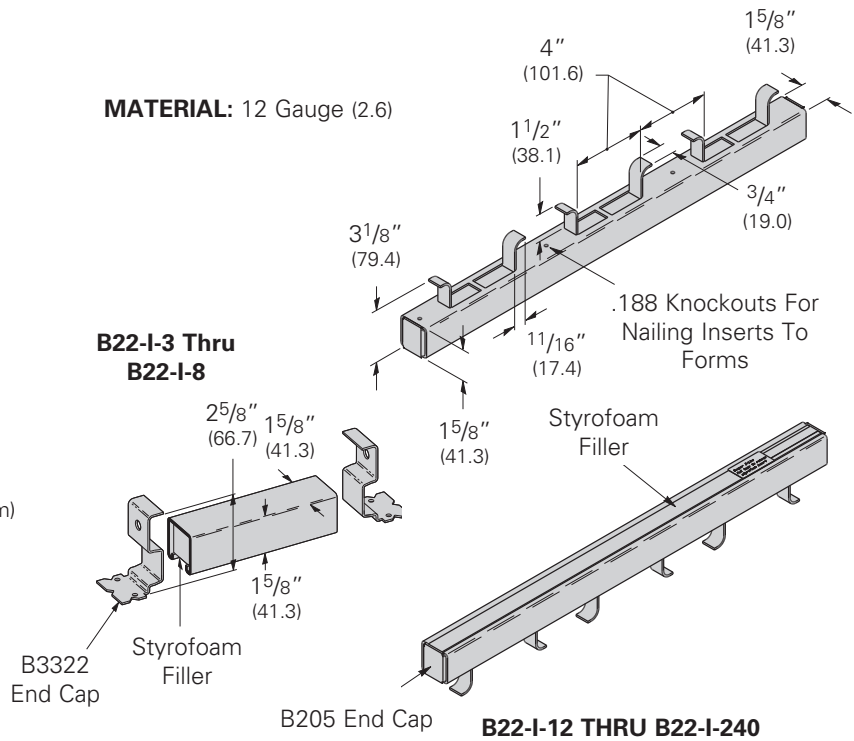

Part No.	Length		Wt./C		Design Load	
	in.	mm	Lbs.	kg	Lbs.	kN
B22-I-3	3"	(76)	72	(32.6)	500	(2.22)
B22-I-4	4"	(101)	88	(39.9)	800	(3.56)
B22-I-6	6"	(152)	120	(54.4)	1000	(4.45)
B22-I-8	8"	(203)	152	(68.9)	1200	(5.34)

Part No.	Length		Wt./C	
	in.	mm	Lbs.	kg
B22-I-12	12"	(305)	224	(101.6)
B22-I-16	16"	(406)	289	(131.1)
B22-I-20	20"	(508)	353	(160.1)
B22-I-24	24"	(609)	420	(190.5)
B22-I-32	32"	(813)	553	(250.8)
B22-I-36	36"	(914)	620	(281.2)
B22-I-40	40"	(1016)	686	(311.1)
B22-I-48	48"	(1219)	820	(371.9)
B22-I-60	60"	(1524)	1018	(461.7)
B22-I-72	72"	(1829)	1218	(552.5)
B22-I-84	84"	(2133)	1417	(642.7)
B22-I-96	96"	(2438)	1616	(733.0)
B22-I-108	108"	(2743)	1816	(823.7)
B22-I-120	120"	(3048)	2016	(914.4)
B22-I-144	144"	(3657)	2416	(1095.9)
B22-I-168	168"	(4267)	2816	(1277.3)
B22-I-192	192"	(4877)	3216	(1458.7)
B22-I-216	216"	(5486)	3616	(1640.2)
B22-I-240	240"	(6096)	4016	(1821.6)

Reference page 254 for general fitting and standard finish specifications

Continuous Concrete Inserts

B32I Continuous Concrete Insert

- Design Load for B32-I-12 thru B32-I-240 is 2,000 lbs. (8.89 kN) per foot of concrete insert length with safety factor of 3 in 3000 psi concrete.
- Loads concentrated within the last 2 inches (50.8 mm) of concrete inserts 8" (203.2 mm) and longer should not exceed 1,000 lbs. (4.45kN).
- Concrete insert should be secured to the forms on 16" (406.4 mm) to 24" (609.6 mm) intervals.
- B32-I continuous concrete inserts are made from B32 channel. Use channel nuts designed for use in B32 channel.
- B32-I concrete inserts are supplied with styrofoam fillers. B3332 end caps are furnished with inserts through 8" (203.2 mm) long, and B206 end caps are furnished with inserts 12" (304.8 mm) and longer.
- Material: Plain Steel ASTM A1011 33,000 PSI min. yield or Pre-Galvanized Steel ASTM A653SS 33,000 PSI min. yield.
- Finish: Plain, DURA GREEN™, Pre-Galv, HDG

MATERIAL: 12 Gauge (2.6)

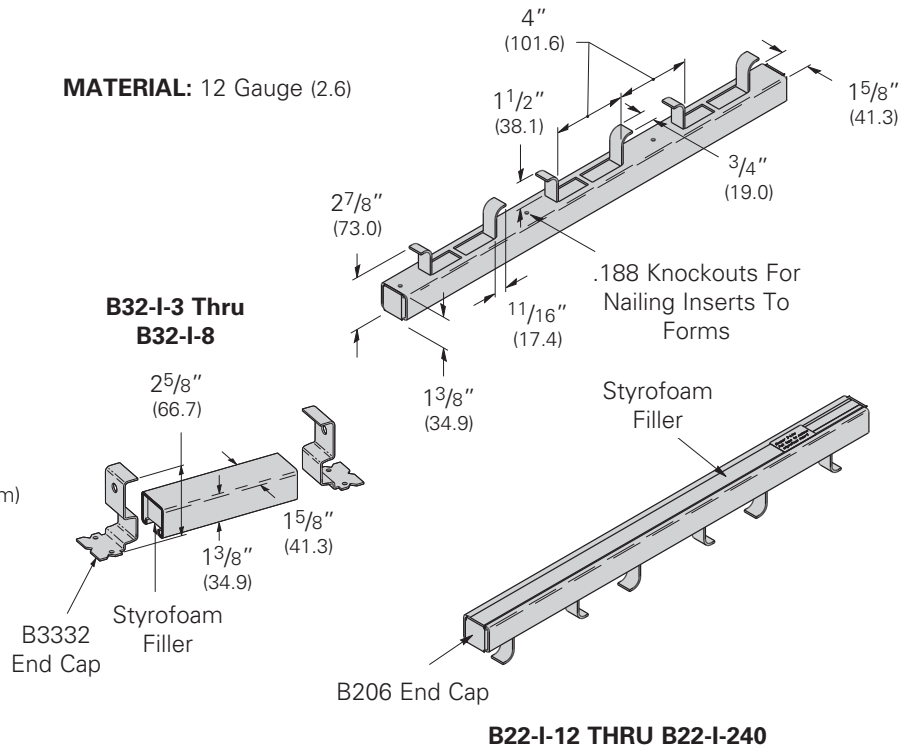

Part No.	Length		Wt./C		Design Load	
	in.	mm	Lbs.	kg	Lbs.	kN
B32-I-3	3"	(76)	65	(29.5)	500	(2.22)
B32-I-4	4"	(101)	80	(36.3)	800	(3.56)
B32-I-6	6"	(152)	108	(49.0)	1000	(4.45)
B32-I-8	8"	(203)	137	(62.1)	1200	(5.34)

Part No.	Length		Wt./C	
	in.	mm	Lbs.	kg
B32-I-12	12"	(305)	202	(91.6)
B32-I-16	16"	(406)	262	(118.8)
B32-I-20	20"	(508)	316	(143.3)
B32-I-24	24"	(609)	376	(170.5)
B32-I-32	32"	(813)	496	(225.0)
B32-I-36	36"	(914)	556	(252.2)
B32-I-40	40"	(1016)	616	(279.4)
B32-I-48	48"	(1219)	736	(333.8)
B32-I-60	60"	(1524)	915	(415.0)
B32-I-72	72"	(1829)	1095	(496.7)
B32-I-84	84"	(2133)	1274	(577.9)
B32-I-96	96"	(2438)	1453	(659.0)
B32-I-108	108"	(2743)	1633	(740.7)
B32-I-120	120"	(3048)	1813	(822.3)
B32-I-144	144"	(3657)	2173	(985.6)
B32-I-168	168"	(4267)	2533	(1148.9)
B32-I-192	192"	(4877)	2893	(1312.2)
B32-I-216	216"	(5486)	3253	(1475.5)
B32-I-240	240"	(6096)	3613	(1638.8)

Reference page 254 for general fitting and standard finish specifications.

Continuous Concrete Inserts

B52I Continuous Concrete Insert

- Design Load for B52-I-12 thru B52-I-240 is 1,500 lbs. (6.67 kN) per foot of concrete insert length with safety factor of 3 in 3000 psi concrete.
- Loads concentrated within the last 2 inches (50.8 mm) of concrete inserts 8" (203.2 mm) and longer should not exceed 750 lbs. (3.33kN).
- Concrete insert should be secured to the forms on 16" (406.4 mm) to 24" (609.6 mm) intervals.
- B52-I continuous concrete inserts are made from B52 channel. Use channel nuts designed for use in B52 channel.
- B52-I concrete inserts are supplied with styrofoam fillers. B3352 end caps are furnished with inserts through 8" (203.2 mm) long, and B220 end caps are furnished with inserts 12" (304.8 mm) and longer.
- Material: Plain Steel ASTM A1011 33,000 PSI min. yield or Pre-Galvanized Steel ASTM A653SS 33,000 PSI min. yield.
- Finish: Plain, DURA GREEN™, Pre-Galv, HDG

MATERIAL: 12 Gauge (2.6)

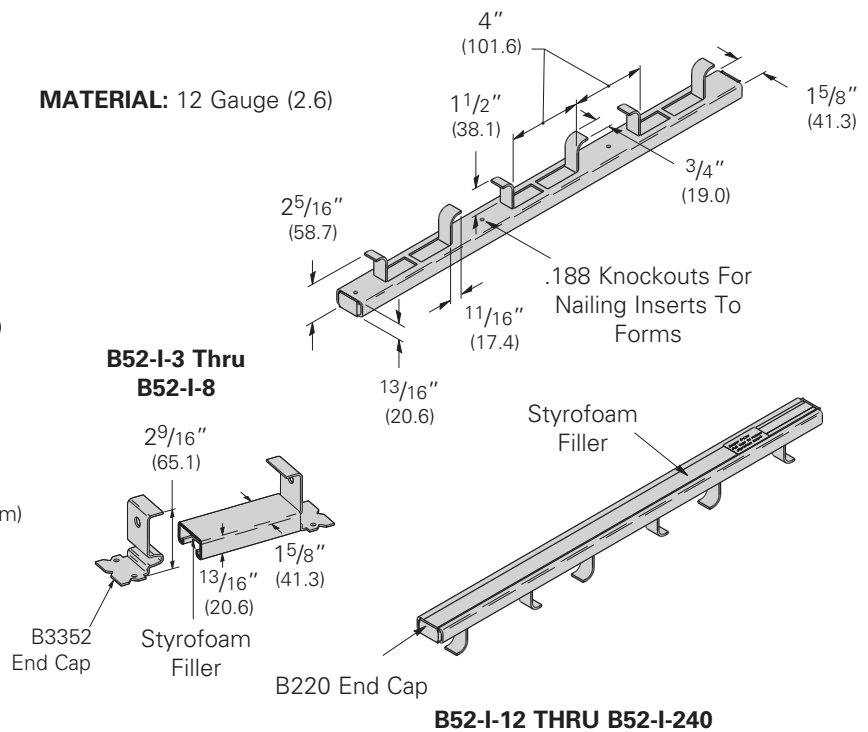

Part No.	Length		Wt./C		Design Load	
	in.	mm	Lbs.	kg	Lbs.	kN
B52-I-3	3"	(76)	53	(24.0)	400	(1.78)
B52-I-4	4"	(101)	63	(28.6)	500	(2.22)
B52-I-6	6"	(152)	85	(38.5)	750	(3.33)
B52-I-8	8"	(203)	106	(48.1)	1000	(4.45)

Part No.	Length		Wt./C	
	in.	mm	Lbs.	kg
B52-I-12	12"	(305)	157	(71.2)
B52-I-16	16"	(406)	202	(91.6)
B52-I-20	20"	(508)	237	(107.5)
B52-I-24	24"	(609)	282	(127.9)
B52-I-32	32"	(813)	373	(169.2)
B52-I-36	36"	(914)	419	(190.0)
B52-I-40	40"	(1016)	464	(210.4)
B52-I-48	48"	(1219)	556	(252.2)
B52-I-60	60"	(1524)	692	(313.9)
B52-I-72	72"	(1829)	829	(376.0)
B52-I-84	84"	(2133)	965	(437.7)
B52-I-96	96"	(2438)	1107	(502.1)
B52-I-108	108"	(2743)	1237	(561.1)
B52-I-120	120"	(3048)	1374	(623.2)
B52-I-144	144"	(3657)	1648	(747.5)
B52-I-168	168"	(4267)	1922	(871.8)
B52-I-192	192"	(4877)	2196	(996.1)
B52-I-216	216"	(5486)	2470	(1120.4)
B52-I-240	240"	(6096)	2744	(1244.6)

Reference page 254 for general fitting and standard finish specifications

B2500 Spot Insert

- Design Load 600 Lbs. (2.67 kN)
- Safety Factor of 5
- Order N2500 Nuts Separately
- Material: Steel ASTM A1011
33,000 PSI min. yield
- Standard finish: ZN
- Wt./C 46 Lbs. (20.8 kg)

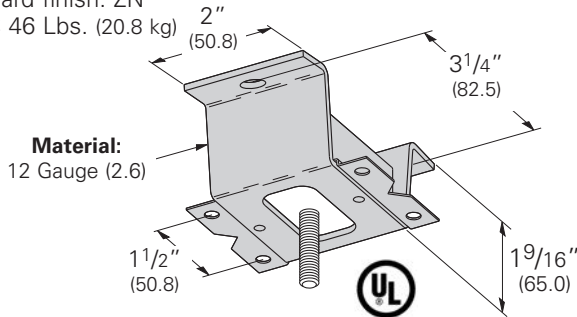

N2500 Insert Square Nut

- For use in B2500 Spot Insert
- Material: Steel ASTM A36
- Standard finish: ZN

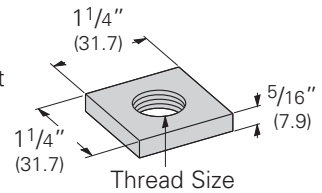

Part No.	Thread Size	Wt./C	
		Lbs.	kg
N2500-1/4	1/4"-20	13	(5.9)
N2500-5/16	5/16"-18	13	(5.9)
N2500-3/8	3/8"-16	12	(5.4)
N2500-1/2	1/2"-13	12	(5.4)
N2500-5/8	5/8"-11	11	(5.0)
N2500-3/4	3/4"-10	10	(4.5)
N2500-7/8	7/8"-9	9	(4.1)

B2503 Heavy Duty Spot Insert

- Designed for use where heavy loads are required in curtain wall applications
- Design Load is 5000 Lbs. (22.2 kN) with a Safety Factor of 3
- Loading based on two N225 channel nuts spaced 3" (76.2 mm) on center and a minimum of 2" (50.8 mm) from the end of the insert
- Styrofoam end caps prevent concrete seepage into the channel
- 12" (304.8 mm) long insert is anchored into the concrete at a depth of 5 1/2" (139.7 mm)
- Material: 12 Gauge (2.6 mm) thick steel
- Standard finish: ZN
- Wt./C 42 Lbs. (19.0 kg)

B2505 Thru B2508 Spot Insert

- Safety Factor of 5
- To support 10" (250) pipe use B2505 insert with 5/8"-11 Channel Nuts.
- To support up to and including 8" (200) pipes use B2506, B2507 and B2508 inserts with the desired Channel Nuts.
- Standard finish: ZN

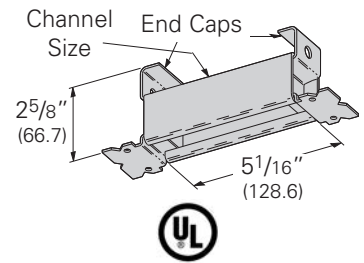

Part No.	Channel Style	End Cap Part No.	Design Load		Maximum Pipe Size	Wt./C	
			Lbs.	kN		Lbs.	kg
B2505	B22	B3322	1200	(5.34)	10" (250)	96	(43.5)
B2506	B32	B3332	1000	(4.45)	8" (200)	88	(39.9)
B2507	B42	B3342	1000	(4.45)	8" (200)	77	(34.9)
B2508	B52	B3352	1000	(4.45)	8" (200)	69	(31.3)

B2501 Light Duty Spot Insert

- Safety Factor of 2
- The concrete attachment problem solver for light duty applications.
- Fast and easy applications.
- No concrete leakage problems.
- One piece unitized construction.
- Color coded cap on thread for rod size identification and to prevent concrete seepage. (1/4"-Yellow, 3/8"-Red, 1/2"-Blue)

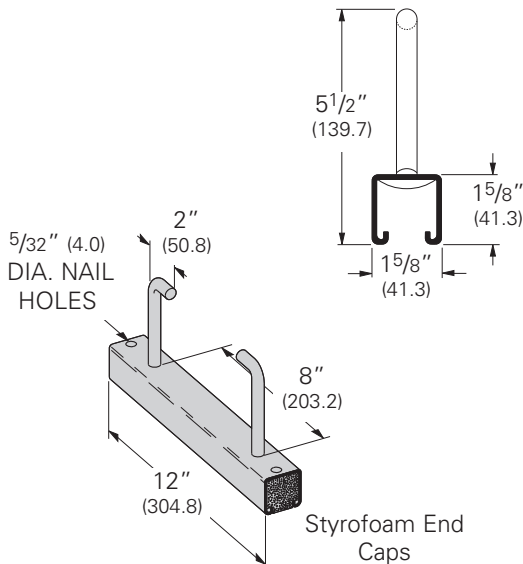
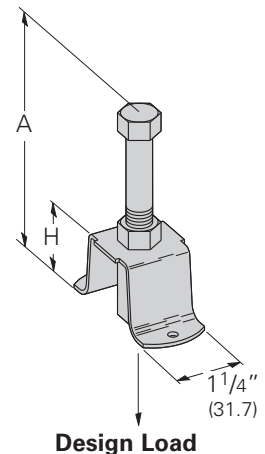

Part No. & Size	Height A		Height H		Design Load		Wt./C	
	In.	mm	In.	mm	Lbs.	kN	Lbs.	kN
B2501-1/4	2 7/16"	(61.9)	7/8"	(22.2)	250	(1.11)	16	(7.2)
B2501-3/8	3 1/16"	(77.8)	1 7/8"	(47.6)	610	(2.71)	22	(9.9)
B2501-1/2	4 1/8"	(104.8)	1 7/8"	(47.6)	880	(3.91)	26	(11.7)

Reference page 254 for general fitting and standard finish specifications.

Insert Accessories

B205, B206, B220 X Type End Caps

- UL listed for raceway use only
- Material: 12 Gauge (2.6)
- Standard finish: ZN

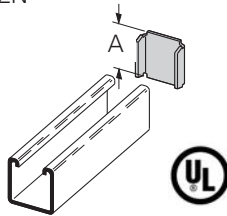

Part No.	Use With	A		Wt./C	
		In.	mm	Lbs.	kg
B205	B22	1 ²¹ / ₃₂ "	(42.0)	10	(4.5)
B206	B32	1 ¹³ / ₃₂ "	(35.7)	8	(3.6)
B220	B52	2 ⁷ / ₃₂ "	(21.4)	4	(1.8)

B3322, B3332, B3342, B3352 Y Type End Caps

- UL listed for raceway use only
- Material: 14 Gauge (1.9)
- Standard finish: ZN

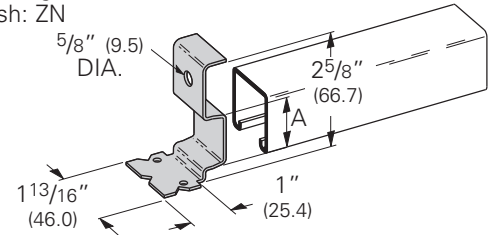

Part No.	Use With	A		Wt./C	
		In.	mm	Lbs.	kg
B3322	B22	1.270	(32.2)	15	(6.8)
B3332	B32	1.000	(25.4)	15	(6.8)
B3342	B42	.645	(16.4)	15	(6.8)
B3352	B52	.460	(11.7)	15	(6.8)

B380 Joint Splice Plate

- Used at splice points to prevent concrete seepage in long continuous runs of concrete inserts.
- Material: 18 Gauge (1.2)
- Standard finish: GALV

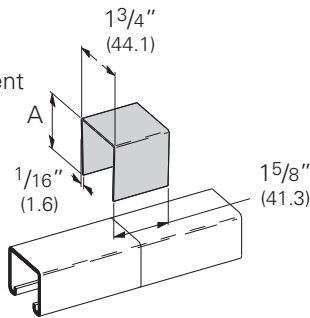

Part No.	Use With	A		Wt./C	
		In.	mm	Lbs.	kg
B380-22	B22	1 ⁵ / ₈ "	(41.3)	11	(5.0)
B380-32	B32	1 ³ / ₈ "	(34.9)	10	(4.5)
B380-42	B42	1"	(25.4)	9	(4.1)
B380-52	B52	1 ³ / ₁₆ "	(20.6)	7	(3.2)

B22IFS-B52IFS Styrofoam Filler Strip

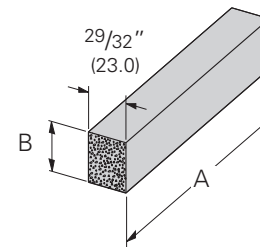

Part No.	A		B		Wt./C
	Ft.	mm	In.	mm	
B22-IFS	4'	(1219)	1 ⁷ / ₃₂ "	(309)	10 (4.5)
B32-IFS	4'	(1219)	1"	(254)	9 (4.1)
B52-IFS	4'	(1219)	2 ¹ / ₃₂ "	(167)	7 (3.2)

Concrete Inserts

Pipe Sleeve Fasteners

- Allows for rigid attachment of pipe sleeves to wall and floor forms for concrete pouring.
- Accommodates Schedule 40, Schedule 80, or 5/16" (8) and smaller wall thickness.
- Simply installed with a hammer.

Part No.	Sleeve Diameter	Wall Thickness
BD40	All Dia.	5/16" & under
BE-5-8	6"	Schedule 80 pipe
BE-9-12	9" - 14"	Schedule 80 pipe

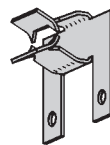

BD40

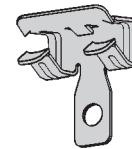

BE-5-8 & BE-9-12

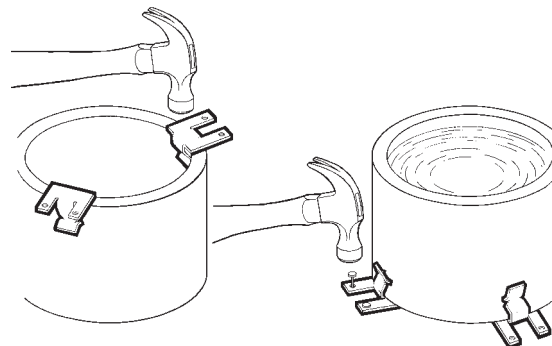

Reference page 254 for general fitting and standard finish specifications

Wedge Anchors †

- Heavy and medium duty all purpose anchor.
- For use in solid concrete and grout filled block.
- Anchors can be installed through the fixture, no need for hole spotting.
- **UL** (Underwriters Laboratories) Listed
- **FM** (Factory Mutual) Approved
- Available in Zinc Plated Carbon Steel or Type 304 Stainless Steel.

† Not ICC-ES Certified



Wedge Anchor - Data	1/4"	3/8"	1/2"	5/8"
ANSI Drill Bit Size (in.)	1/4	3/8	1/2	5/8
Fixture Clearance Hole (in.)	5/16	7/16	9/16	11/16
Thread Size (UNC)	1/4"-20	3/4"-16	1/2"-13	5/8"-11
Washer O.D. (in.)	5/8	13/16	11/16	13/4
Wrench Size	7/16	9/16	3/4	15/16
Max. Tightening Torque (ft-lbs)	8	28	60	90
Min. Embedment Depth (in.)	1 1/8	1 5/8	2 1/4	2 3/4
Load Capacity Tension (lbs) *	415	775	1200	1570
Load Capacity Shear (lbs) *	325	635	1050	1705

* Based on concrete compression strength of 4,000 psi using applied safety factor of 4.

Catalog Number	Size	Thread Length
----------------	------	---------------

Zinc Plated Carbon Steel

AWA-25-175	1/4" x 1 3/4"	3/4"
AWA-25-225	1/4" x 2 1/4"	1 1/4"
AWA-25-325	1/4" x 3 1/4"	2 1/4"
AWA-37-225	3/8" x 2 1/4"	1 1/4"
AWA-37-275	3/8" x 2 3/4"	1 5/8"
AWA-37-300	3/8" x 3"	1 7/8"
AWA-37-350	3/8" x 3 1/2"	2 3/8"
AWA-37-375	3/8" x 3 3/4"	2 5/8"
AWA-37-500	3/8" x 5"	3 7/8"
AWA-50-275	1/2" x 2 3/4"	1 3/8"
AWA-50-375	1/2" x 3 3/4"	2 3/8"
AWA-50-450	1/2" x 4 1/2"	3 1/8"
AWA-50-550	1/2" x 5 1/2"	4 1/8"
AWA-50-700	1/2" x 7"	5 5/8"
AWA-62-275	5/8" x 3 1/2"	2"
AWA-62-375	5/8" x 4 1/2"	3"
AWA-62-450	5/8" x 5"	3 1/2"
AWA-62-550	5/8" x 6"	4 1/2"
AWA-62-700	5/8" x 7"	5 1/2"

Stainless Steel

AWA-25-175SS4	1/4" x 1 3/4"	3/4"
AWA-25-225SS4	1/4" x 2 1/4"	1 1/4"
AWA-25-325SS4	1/4" x 3 1/4"	2 1/4"
AWA-37-225SS4	3/8" x 2 1/4"	1 1/4"
AWA-37-275SS4	3/8" x 2 3/4"	1 5/8"
AWA-37-300SS4	3/8" x 3"	1 7/8"
AWA-37-350SS4	3/8" x 3 1/2"	2 3/8"
AWA-37-375SS4	3/8" x 3 3/4"	2 5/8"
AWA-37-500SS4	3/8" x 5"	3 7/8"
AWA-50-275SS4	1/2" x 2 3/4"	1 3/8"
AWA-50-375SS4	1/2" x 3 3/4"	2 3/8"
AWA-50-450SS4	1/2" x 4 1/2"	3 1/8"
AWA-50-550SS4	1/2" x 5 1/2"	4 1/8"
AWA-50-700SS4	1/2" x 7"	5 5/8"
AWA-62-275SS4	5/8" x 3 1/2"	2"
AWA-62-375SS4	5/8" x 4 1/2"	3"
AWA-62-450SS4	5/8" x 5"	3 1/2"
AWA-62-550SS4	5/8" x 6"	4 1/2"
AWA-62-700SS4	5/8" x 7"	5 1/2"

Seismic Wedge Anchors

- Fully threaded, torque-controlled wedge anchor which is designed for consistent performance in cracked and uncracked concrete.
- For use in concrete, structural sand lightweight concrete, and concrete over metal deck.
- Nominal drill bit size is the same as the anchor diameter.
- **ICC-ES Listed**, ESR-2502, Category 1.
- **UL** (Underwriters Laboratories) Listed
- **FM** (Factory Mutual) Approved
- Zinc Plated Carbon Steel with stainless steel expansion clip for premium performance.

Consult factory for sizes and other information.



Reference page 254 for general fitting and standard finish specifications.

Anchors

Concrete Screw Bolts

- For use in racking, shelving, material handling, structural anchorage, masonry and food & beverage facilities.
- One piece heavy-duty anchor with a finished hex-head.
- Fast installation and immediate loading reduces downtime.
- For proper performance, screw anchors must be installed with the corresponding bits. The bits have a matched tolerance range designed to provide optimum performance.
- **ICC-ES Listed, ESR 2526**, qualified for static, seismic and wind loading in concrete.
- **ICC-ES Listed, ESR 4042**, qualified for static, wind and seismic loading in grouted masonry.

Catalog Number	Anchor Length	Thread Length
Screw Type Anchor - Steel		
ACB-25-175	1/4" x 1 3/4"	1 5/8"
ACB-25-225	1/4" x 2 1/4"	2"
ACB-25-300	1/4" x 3"	2 3/4"
ACB-37-175	3/8" x 1 3/4"	1 1/2"
ACB-37-250	3/8" x 2 1/2"	2 1/4"
ACB-37-300	3/8" x 3"	2 3/4"
ACB-37-400	3/8" x 4"	3 3/4"



Catalog Number	Drill Size	Usable Length	Overall Length
Drill Bits - Straight Shank Type			
1372	1/4"	4"	6"
1380	3/8"	4"	6"
Drill Bits - SDS Type			
1314	1/4"	4"	6"
1316	3/8"	4"	6"



Straight Shank Drill Bit



SDS Hex Drill Bit

Note: Matched tolerance bits must be used for installation.

Concrete Screw Bolts - Data	1/4"	3/8"
ACB Drill Bit Size (in.)	1/4	3/8
Min. Embedment Depth (in.)	1	1 1/2
Load Capacity Tension (lbs) *	385	835
Load Capacity Shear (lbs) *	480	1125

* Based on concrete compression strength of 4000 psi in uncracked concrete using applied safety factor of 4.0. For additional loading information contact factory. For ultimate strength design data in cracked and uncracked concrete, see ICC-ES ESR-3889.

Reference page 254 for general fitting and standard finish specifications

Concrete Screws

- Light to medium duty anchor for use in concrete, masonry block and brick base materials.
- Concrete screws are engineered with matched tolerance bits and installation tools to optimize performance.
- High low thread design for greater stability and grip.
- No hole spotting required.
- One drill bit is packaged in each box of concrete screws.
- Blue fluorocarbon coating for corrosion resistance.

Catalog Number	Size
----------------	------

Hex Head Concrete Screws

ACS-18-125H †	3/16" x 1 1/4"
ACS-18-175H †	3/16" x 1 3/4"
ACS-18-225H	3/16" x 2 1/4"
ACS-18-275H	3/16" x 2 3/4"
ACS-18-325H	3/16" x 3 1/4"
ACS-18-375H	3/16" x 3 3/4"
ACS-18-400H	3/16" x 4"
ACS-25-125H †	1/4" x 1 1/4"
ACS-25-175H †	1/4" x 1 3/4"
ACS-25-225H	1/4" x 2 1/4"
ACS-25-275H	1/4" x 2 3/4"
ACS-25-325H	1/4" x 3 1/4"
ACS-25-375H	1/4" x 3 3/4"
ACS-25-400H	1/4" x 4"

Flat Head Concrete Screws

ACS-18-125F †	3/16" x 1 1/4"
ACS-18-175F †	3/16" x 1 3/4"
ACS-18-225F	3/16" x 2 1/4"
ACS-18-275F	3/16" x 2 3/4"
ACS-25-125F †	1/4" x 1 1/4"
ACS-25-175F †	1/4" x 1 3/4"
ACS-25-225F	1/4" x 2 1/4"
ACS-25-275F	1/4" x 2 3/4"

† Not ICC-ES listed

Hex Head

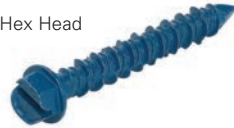

Hex Head - Data	3/16"	1/4"
ANSI Drill Bit Size (in.)	5/32	3/16
Fixture Clearance Hole (in.)	1/4	5/16
Head Height (in.)	7/64	9/64
Head Width (in.)	1/4	5/16
Washer O.D. (in.)	11/32	13/32
Washer Thickness (in.)	1/32	1/32
Hex Driver (in.)	1/4	5/16

Flat Head



Flat Head - Data	3/16"	1/4"
ANSI Drill Bit Size (in.)	5/32	3/16
Fixture Clearance Hole (in.)	1/4	5/16
Phillips Head O.D. (in.)	3/8	1/2
Phillips Head Height (in.)	9/64	3/16
Phillips Bit Size	2	3

Embedment Depth	Nominal Anchor Dia. / Loading*			
	3/16" Tension	3/16" Shear	1/4" Tension	1/4" Shear
1 3/4"	360	240	555	375

* Based on concrete compression strength of 4000 psi using applied safety factor of 4.0. For additional loading information contact factory.

ICC-ES Listed, ESR 3068, qualified for static, wind and loading in concrete.

ICC-ES Listed, ESR 1678, qualified for static, wind and seismic loading in grouted concrete.

ICC-ES Listed, ESR 3213, qualified for use in chemically treated wood.

ICC-ES Listed, ESR 3042, qualified for use in wood.



Straight Shank Drill Bit



SDS Hex Drill Bit

Catalog Number	Bit Size	Usable Length
----------------	----------	---------------

Straight Shank Drill Bits

2782SD	5/32" x 4 1/2"	3"
2786SD	3/16" x 4 1/2"	3"

SDS Hex Drill Bits

2793	5/32" x 5"	3"
2796	3/16" x 5"	3"



Catalog Number	Description
----------------	-------------

Setting Tool

2791	Concrete Screw Tool Kit
-------------	-------------------------

Reference page 254 for general fitting and standard finish specifications.

Anchors

Wood-Knocker™† II Anchors

- Wood-Knocker concrete inserts are installed on wooden forms used to support newly poured concrete floors, roof slabs, or walls.
- When the forms are stripped, the color-coded flange is visibly embedded in the concrete surface.
- The unique, six-sided impact plate offers resistance to rotation within the concrete as threaded rod is being installed.
- Suitable for overhead installations such as suspending cable tray, pipe hangers, strut, and conduit.
- Color coded by size for all trades.
- Lowest in-place cost.
- **ICC-ES** Certified. See ICC-ESR-3657
- **UL** (Underwriters Laboratories) Listed
- **FM** (Factory Mutual) Approved



Wood-Knocker™ II Anchors

Catalog Number	Rod Diameter	Color
ACPW-25-2	1/4"	Brown
ACPW-37-2	3/8"	Green
ACPW-3750-2	3/8"-1/2"	Gray
ACPW-50-2	1/2"	Yellow
ACPW-62-2	5/8"	Red
ACPW-75-2	3/4"	Purple

Wood Knocker™ - Data	1/4"	3/8"	1/2"	5/8"	3/4"
Insert Thread Length (in.)	3/8	5/8	11/16	15/16	1 1/8
Plastic Flange Diameter (in.)	1 3/8	1 3/8	1 3/8	1 5/8	1 5/8
Thread Size (UNC)	1/4"-20	3/8"-16	1/2"-13	5/8"-11	3/4"-10
Overall Length (in.)	1 7/8	1 7/8	1 7/8	1 7/8	1 7/8
Min. Insert Spacing (in.)	9	9	9	12	12
Min. End Distance (in.)	6	6	6	9	9
Load Capacity Tension (lbs) *	1240	1605	1605	1550	1550
Load Capacity Shear (lbs) *	495	1775	2465	3785	3785

* Based on normal weight concrete with minimum compression strength of 3000 psi. Allowable load capacities are calculated using applied safety factor of 4.0. For additional loading information contact factory.
Minimum embedment depth is 2".

† Wood-Knocker™ is a registered trademark used by DeWalt

Reference page 254 for general fitting and standard finish specifications

Bang-It™† + Anchors

- Bang-It concrete inserts are designed for installation in and through metal composite deck used to support newly poured concrete floors or roof slabs.
- After installation, the protective sleeve of the insert protrudes below the surface of the deck, allowing overhead attachment of threaded rod.
- The unique, six sided impact plate offers resistance to rotation within the concrete as threaded rod is being installed.
- Suitable for overhead installations such as suspending cable tray, pipe hangers, strut, and conduit.
- Color coded by size for all trades.
- **ICC-ES** Certified. See ICC-ESR-3657
- **UL** (Underwriters Laboratories) Listed
- **FM** (Factory Mutual) Approved
- Lowest in-place cost.



Bang-It™ + Anchors

Catalog Number	Rod Diameter	Color
ACPD-25	1/4"	Brown
ACPD-37	3/8"	Green
ACPD-3750-2	3/8"-1/2"	Gray
ACPD-50	1/2"	Yellow
ACPD-62	5/8"	Red
ACPD-75	3/4"	Purple

Carbide Hole Saw for Bang-It™ + Anchors

Catalog Number	Description
ACPD-HS813-2	13/16" diameter for 1/4", 3/8", & 1/2" sizes
ACPD-HS1188-2	13/16" diameter for 5/8" & 3/4" sizes

Bang-It™ - Data	1/4"	3/8"	1/2"	5/8"	3/4"
Metal Hole Saw Diameter (in.)	13/16	13/16	13/16	13/16	13/16
Drilling Speed (rpm)	700-900	700-900	700-900	500-700	500-700
Insert Thread Length (in.)	3/8	5/8	11/16	15/16	11/8
Length of Sleeve (in.)	33/8	33/8	33/8	33/8	33/8
Thread Size (UNC)	1/4"-20	3/8"-16	1/2"-13	5/8"-11	3/4"-10
Embedment Depth (in.)	2	2	2	2	2
Upper Deck Tension Load (lbs) *	1115	1915	2370	2935	2935
Lower Deck Tension Load (lbs) *	830	830	830	930	990
Upper Deck Shear Load (lbs) *	835	1115	1115	1115	1115
Lower Deck Shear Load (lbs) *	625	840	840	840	840

* Based on sand lightweight and normal weight concrete with minimum compressio strength of 3000 psi over steel deck.

Allowable load capacities are calculated using applied safety factor of 4.0.

For additional loading information contact factory.

Minimum insert spacing of 6", minimum end spacing 6".

† Bang-It™ is a registered trademark used by DeWalt

Reference page 254 for general fitting and standard finish specifications.

Anchors

Rapid Rod™ Hangers for Steel †

- One-piece, all steel threaded fastener system for suspending steel threaded rod.
- Suitable for overhead installations such as suspending cable tray, pipe hangers, strut and conduit.
- Side Mount (SW) available for side mounting applications.
- Lower in-place cost, when compared to beam clamps, lag bolts and drop-ins.
- Steel rapid rods can be installed with a screw gun or hammer drill.
- **UL** (Underwriters Laboratories) Listed
- **FM** (Factory Mutual) Approved
- Made of Zinc Plated carbon steel.



† Not ICC-ES Certified

Catalog Number	Rod Size	Shank Size & Length
----------------	----------	---------------------

Steel Rod Hanger - Point Style #3 For Purlins

ARS-25-100-2	1/4"	1/4" x 1"
ARS-37-100HN-2 **	3/8"	1/4" x 1" w/nuts
ARS-37-150-2	3/8"	1/4" x 1 1/2"
ARS-37-150HN-2 **	3/8"	1/4" x 1 1/2" w/nuts
ARS-37-200-2	3/8"	1/4" x 2"

Steel Rod Hanger - Side Mount - Point Style #3 For Purlins

ARS-25-100SW-2	1/4"	1/4" x 1" w/nuts
ARS-37-100SW-2	3/8"	1/4" x 1" w/nuts

Steel Rod Hanger - Point Style #5 For Purlins

ARS-37-150HDHN-2 **	3/8"	#12-24 x 1 1/2" w/nuts
---------------------	------	------------------------

** For UL & FM listings, steel rapid rod should be installed with a retaining nut.

Catalog Number	Tool Description
7187-2	Steel Socket



Steel Rapid Rod - Data

Description	Rod Size	Min. Thickness	Max. Thickness	Load (Material Thickness)	Load Direction	Pipe Size	Pipe Thickness	Pipe Size	Pipe Thickness
ARS-25-100-2	1/4"	0.060	0.250	593 (0.125")	-	-	-	-	-
ARS-37-100HN-2	3/8"	0.060	0.250	1172 (0.125")	V	4"	0.125"	4"	12 ga.
ARS-37-150-2	3/8"	0.188	0.250	593 (0.125")	V	4"	0.060"	-	-
ARS-37-150HN-2	3/8"	0.060	0.250	1172 (0.125")	V	4"	0.060"	-	-
ARS-37-200-2	3/8"	0.060	0.250	593 (0.125")	V	4"	0.125"	-	-
ARS-25-100SW-2	3/8"	0.060	0.250	642 (0.111")	H	4"	-	-	-
ARS-37-100SW-2	3/8"	0.060	0.250	702 (0.111")	H	4"	0.060"	4"	16 ga.
ARS-37-150HDHN-2	3/8"	0.060	0.250	1452 (0.111")	V	4"	0.125"	4"	12 ga.

Loads shown for ASTM A36 steel beams and ASTM A572 steel purlins include a safety factor of 4.

For UL & FM listings, steel rapid rod must be installed with a retaining nut. UL & FM load rating for 3/8" rapid rod is 365 lbs. and can support up to a maximum 4" pipe.

Steel Rapid Rod - Data

Point Style	#3	#5
Self-Drilling Range (in.)	1/16 - 1/4	1/16 - 1/2
Screw Size (UNC) *	1/4"-20	1/4"-20

* Dimensions for self-drilling (embedded) portion of anchor.

Reference page 254 for general fitting and standard finish specifications

Rapid Rod™ Hangers for Concrete †

Rapid Rod™ Hangers for Wood †

- One-piece, all steel threaded fastener system for suspending steel threaded rod.
- Suitable for overhead installations such as suspending cable tray, pipe hangers, strut and conduit.
- Side Mount (SW) available for side mounting applications.
- Lower in-place cost, when compared to beam clamps, lag bolts and drop-ins.
- Wood rapid rods can be installed with a screw gun or hammer drill.
- Concrete Rapid Rod hangers can be installed with an adjustable torque, battery powered screw gun or hammer drill.
- **UL** (Underwriters Laboratories) Listed
- **FM** (Factory Mutual) Approved
- Made of Zinc Plated carbon steel.



ARC Series

ARW Series

ARW-SW Series

Catalog Number	Rod Size	Shank Size & Length
----------------	----------	---------------------

Concrete Rod Hanger - ANSI Wedge-Bolt OT Thread Shank Style

ARC-25-125	1/4"	1/4" x 15/8"
ARC-37-150	3/8"	1/4" x 15/8"
ARC-37-275	3/8"	3/8" x 23/4"

For side mount concrete applications use ARW-25-100SW or ARW-37-200SW with 3/16" drill bit.

Wood Rod Hanger - Point Style Type 17

ARW-25-200	1/4"	1/4" x 2"
ARW-37-100	3/8"	1/4" x 1"
ARW-37-200	3/8"	1/4" x 2"
ARW-37-250	3/8"	5/16" x 2 1/2"
ARW-50-250	1/2"	5/16" x 2 1/2"

Wood Rod Hanger - Side Mount - Point Style Type 17

ARW-25-100SW	1/4"	1/4" x 1"
ARW-37-200SW	3/8"	1/4" x 2"

Catalog Tool Number Description

Tools

7187-2	Wood Socket
7195-2	1/4" Concrete Socket
7197-2	3/8" Concrete Socket
5874	Concrete Tapper Sleeve Assy.
5866	1/4" X 6" Hex Shank SDS Drill Bit



7187



7195



7197

Reference page 254 for general fitting and standard finish specifications.

Rapid Rod Hangers - Concrete

Concrete Rapid Rod - Data	1/4"	3/8"	3/8"
ANSI Drill Bit (in.)	1/4	1/4	1/4
Thread Length (in.)	15/8	15/8	2 1/2
Min. Embedment Depth (in.)	15/8	15/8	2 1/2
Load Capacity Tension (lbs.) *	815	815	1050
Load Capacity Shear (lbs.) *	380	525	525

* Based on concrete compression strength of 4000 psi using applied safety factor of 4.0. For additional loading information contact factory.

FM approved load capacity for 3/8" anchor is 365 lbs., maximum 4" pipe size.

Rapid Rod Hangers - Wood

Wood Rapid Rod - Data	1/4" Thread Forming	3/8" Thread Forming
Pre-Drill Diameter (in.)	1/8	1/8
Point Style	Type 17	Type 17

Wood Rapid Rod - Embedment & Load Data (lbs.)

Rod/Anchor Size	Embedment Depth	Fir	Pine	Spruce
1/4"	1"	170	160	160
3/8"	2"	375	375	375
1/2"	2 1/2"	665	775	775

Minimum load ratings are based on a safety factor of 4.

UL approved load capacity for 3/8" rod sizes and 1/4" screw size is 260 lbs., maximum 3" pipe. UL approved load capacity for 3/8" rod sizes and 3/8" screw size is 375 lbs., maximum 4" pipe.

FM approval only applies to 3/8" x 2 1/2" screw size. Approved for 365 lbs., up to 4" pipe.

† Not ICC-ES Certified

Anchors

Self-Tapping Screw Anchors

- For use in normal-weight concrete, structural sand lightweight concrete and concrete over metal deck.
- Anchor design allows for shallow embedment and mechanically interlocks with base material.
- Internally threaded anchor for easy adjustment and removability of threaded rod or bolt.
- Fast anchor installation with a powered impact wrench.
- Suitable for overhead applications such as suspending cable tray, strut, pipe hangers and conduit.
- **FM** Approved.
- **ICC-ES** certified. See ICC-ES ESR-2272.
- Made of Zinc Plated carbon steel.
- Setting tool included.



ATM-37 Anchor

Catalog Number	Size	Thread Depth
Self-Tapping Screw Anchor		
ATM-37	3/8"	1 1/16"
Tool		
6407 SD	3/8"	--



6407 SD Tool

ICC-ES certified. See ICC-ES ESR-2272.

Self-Tapping Machine Screw - Data	3/8"
ANSI Drill Bit Size (in.)	1/2
Min. Concrete Thickness (in.)	4
Max. Tightening Torque (ft-lbs)	8
Min. Embedment Depth (in.)	1 5/8
Load Capacity Tension (lbs) *	590
Load Capacity Shear (lbs) *	260

* Based on concrete compression strength of 3000 psi in uncracked concrete using applied safety factor of 4.0.

For additional loading information contact factory. The shear capacity is controlled by steel strength and is ASTM A36 (or equivalent).

For ultimate strength design data in cracked and uncracked concrete, see ICC-ES ESR-2272.

Sleeve Type Expansion Anchors

- For use in concrete and masonry substrates.
- Suitable for solid and hollow core materials.
- Fits standard fixture holes - no need to undersize anchors for proper fit.
- Sleeve has 360° contact area and reduces concrete stress.
- **UL** Listed and **FM** Approved
- Zinc Plated Steel and (Type 304 Stainless Steel ** add SS4 to part number)



Hex Nut (HN) Style



Acorn Nut (AN) Style



Slotted Round Head (RS) Style

Sleeve Type Expansion - Data	1/4"	3/8"	1/2"	5/8"	3/4"
ANSI Drill Bit Size (in.)	1/4	3/8	1/2	5/8	3/4
Fixture Clearance Hole (in.)	5/16	7/16	9/16	11/16	15/16
Plow Bolt Size (UNC)	#10-24	5/16"-18	3/8"-16	1/2"-13	5/8"-11
Min. Embedment Depth (in.)	1/2	1 1/4	1 1/2	2	2 1/4
Load Capacity Tension (lbs) *	65	540	645	1405	1455
Load Capacity Shear (lbs) *	250	1030	1215	1215	2760



For loading information, see ICC-ES ESR-2502.

Rod Hanger (RH) Style

Sleeve Type Expansion - Data	Hanger Rod		
	1/4"	3/8"	1/2"
ANSI Drill Bit Size (in.)	1/4	3/8	1/2
Fixture Clearance Hole (in.)	NA	NA	NA
Plow Bolt Size (UNC)	#10-24	5/16"-18	3/8"-16
Coupling Height (in.)	7/8	1	1 1/4
Min. Embedment Depth (in.)	1/2	1 1/4	1 1/2
Load Capacity Tension (lbs) *	65	540	645
Load Capacity Shear (lbs) *	250	1030	1215

* Based on concrete compression strength of 4000 psi using applied safety factor of 4.0. For additional loading contact factory.

Catalog Number	Size	Thread Length
Hex Nut Style		
ASA-37-187HN	3/8" x 1 7/8" **	1 5/8"
ASA-37-300HN	3/8" x 3" **	1 5/8"
ASA-37-400HN	3/8" x 4"	1 5/8"
ASA-50-225HN	1/2" x 2 1/2" **	2 1/8"
ASA-50-300HN	1/2" x 3" **	2 1/4"
ASA-50-400HN	1/2" x 3 3/4" **	2 1/4"
ASA-50-525HN	1/2" x 5 1/4"	2 1/4"
ASA-50-600HN	1/2" x 6"	2 1/4"
ASA-62-225HN	5/8" x 2 1/2"	2 1/8"
ASA-62-300HN	5/8" x 3"	2 3/4"
ASA-62-425HN	5/8" x 4 1/4" **	2 3/4"
ASA-62-600HN	5/8" x 5 3/4"	2 3/4"
ASA-75-250HN	3/4" x 2 3/4"	2 1/8"
ASA-75-425HN	3/4" x 4 1/4"	3/8"
ASA-75-625HN	3/4" x 6 1/4"	3/8"

Acorn Nut Style

ASA-25-62AN	1/4" x 5/8"	1/2"
ASA-25-137AN	1/4" x 1 3/8"	1 1/8"
ASA-25-225AN	1/4" x 2 1/4"	1 1/8"

Slotted Round Head Style

ASA-25-112RS	1/4" x 1 3/8"	1"
ASA-25-200RS	1/2" x 2 1/4"	1 1/8"

Catalog Number	Size	Drill Diameter
Rod Hanger		
ASA-25-150RH	1/4" x 1 1/2"	5/16"
ASA-37-187RH	3/8" x 1 7/8"	3/8"
ASA-50-225RH	1/2" x 2 1/4"	1/2"

Reference page 254 for general fitting and standard finish specifications

Hollow Base Drop-in Anchors ‡

- For use in hollow base materials such as hollow concrete block, brick with weep holes, and precast hollow core plank.
- Can also be used in solid base materials.
- Smooth wall drop-in can be installed flush mounted or below the base material surface.
- Available in Zinc Plated finish.

Catalog Number	Rod Size	Overall Length	Sleeve Length
Hollow Base Drop-In			
ADH-25	1/4"	7/8"	5/8"
ADH-37	3/8"	15/16"	15/16"
ADH-50	1/2"	13/4"	1 1/4"
Setting Tools			
9323	1/4"	-	-
9343	3/8"	-	-
9353	1/2"	-	-

‡ Not ICC-ES certified



Anchor

Setting Tool

Hollow Base Drop-In - Data	1/4"	3/8"	1/2"
ANSI Drill Bit Size (in.)	3/8	5/8	3/4
Max. Tightening Torque (ft-lbs)	5	10	20
Thread Size (UNC)	1/4"-20	3/8"-16	1/2"-13
Thread Length In Cone (in.)	3/8	5/8	3/4
Min. Embedment Depth (in.)	3/4	1	1 1/2
Load Capacity Tension (lbs) *	230	415	805
Load Capacity Shear (lbs) *	240	510	805

* Based on concrete compression strength of 4000 psi using applied safety factor of 4.0. For additional loading information contact factory.

Wall Screws

- One-piece, all steel anchor with high-profile threads for easy fastening into wallboard and other masonry base materials.
- Deep cutting, corkscrew-like threads provide for smooth entry and a strong hold.
- No pre-drilling is required when fastening into wallboard or wood.
- Fastening into concrete, hollow or grout filled block, brick and plaster requires a pre-drilled 3/16" ANSI hole.
- Installed with a No. 8 drill bit or No. 2 Phillips driver.
- Made of case hardened carbon steel with chrome finish.

Catalog Number	Size	Head Type
Wall Screw		
AWS-CH	3/16" x 1 1/4"	Combo
AWS-OH	3/16" x 1 1/4"	Oval
AWS-PH	3/16" x 1 1/4"	Pan

‡ Not ICC-ES certified



Wall Screw - Data	Minimum Embedment Depth	Load Cap. Tension (lbs.) *	Load Cap. Shear (lbs.) *
Concrete *	3/4"	90	260
1/2" Wallboard	NA	20	60
5/8" Wallboard	NA	35	90
3/4" Plywood	NA	65	150
Grout-Filled Concrete Masonry	1"	55	165
Hollow Concrete Masonry	1"	60	165
Brick Masonry	3/4"	70	120

* Based on concrete compression strength of 4000 psi. Allowable load capacities are calculated using an applied safety factor of 4.0. For additional loading contact factory.

Plastic Screw Anchors

- Designed for use with lightweight fixtures.
- Recommended for use in concrete, block and brick.
- Recommended for light duty static applications where holding power is not critical.
- Not recommended for overhead use.
- Kit includes 100 anchors, 100 screws and one drill bit.
- Made of engineered plastic.

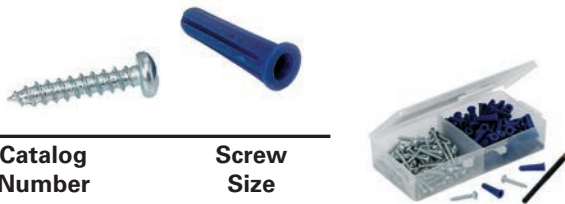

Catalog Number	Screw Size
APC-8K	#8 x 1"
APC-10K	#10 x 1"
APC-12K	#12 x 1"

Plastic Conical Anchor - Data	#8		#10 - #12	
	Tension (lbs.)	Shear (lbs.)	Tension (lbs.)	Shear (lbs.)
Nominal Weight Concrete *	85	70	140	90
Hollow Concrete Masonry **	60	45	70	55
Clay Brick Masonry ***	30	50	55	65
Minimum Embedment Depth	7/8"	7/8"	1"	1"

* Based on concrete compression strength of 4000 psi.

** Based on hollow concrete masonry with minimum compression strength of 1500 psi.

*** Based on clay brick masonry with minimum compression strength of 1500 psi.

Loads contain an applied safety factor of 4.0.

For additional loading information contact factory.

Reference page 254 for general fitting and standard finish specifications.

Slotted Angle

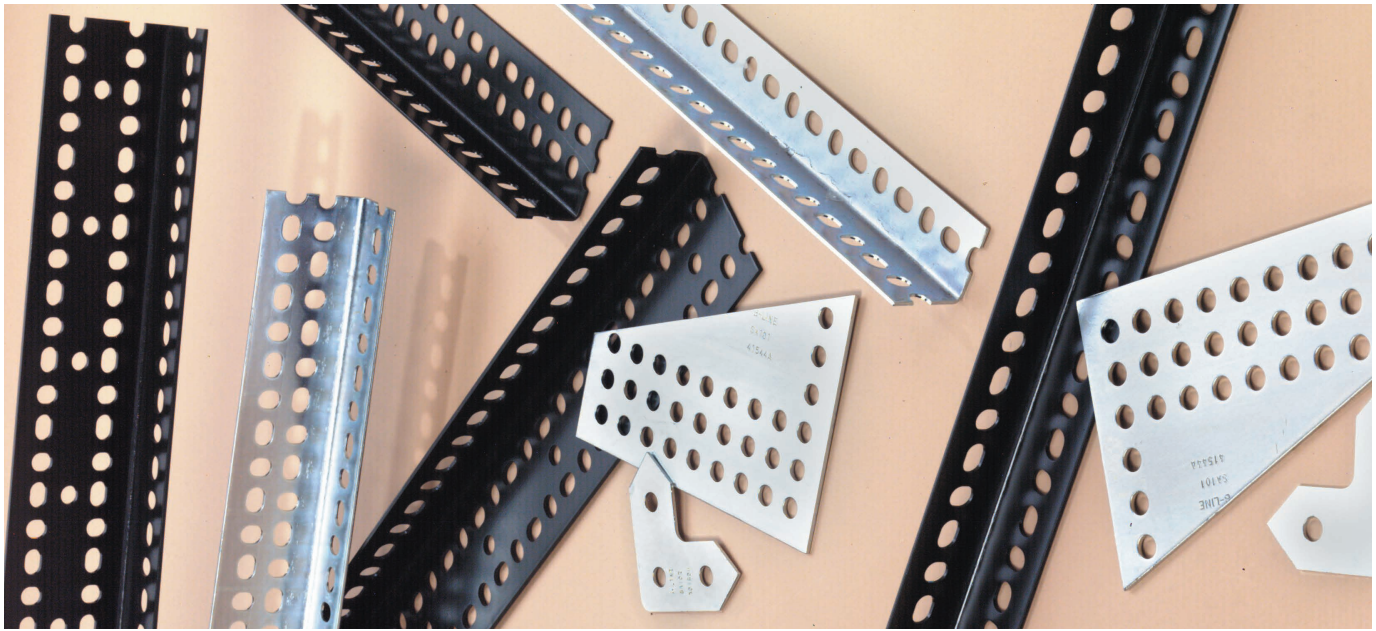

Our slotted angle is an all-purpose framing system, roll formed from high strength steel strips. It is designed to be used as economical shelving, racks or electrical and mechanical supports. The unique pattern of horizontal and vertical slots permits full flexibility. Three basic sizes are available for light, medium, and heavy duty applications.

Materials & Finishes*

Finish Code	Finish	Specification
PLN	Plain	ASTM A1011 33,000 PSI min. yield
ZN	Electro-Plated Zinc	ASTM B633 SC3
GRN	DURA GREEN™	
GALV	Pre-Galvanized	ASTM A653 33,000 PSI min. yield

*Unless otherwise noted.

Lengths

Standard lengths are 10' (3.05 m) and 12' (3.66 m). Slotted angle is shipped in ten piece bundles complete with 60 pieces of 3/8"-16 x 3/4" (19mm) hex head cap screws and 3/8" hex nuts.

Metric

Metric dimensions are shown in parentheses. Unless noted, all metric dimensions are in millimeters.

Slotted Angle Sizes

SA158

- 14 Gauge (1.9)
- $1\frac{5}{8}'' \times 1\frac{5}{8}''$
- Standard finishes: ZN, GRN
- Wt./Ft. .66 Lbs. (.98 kg/m)

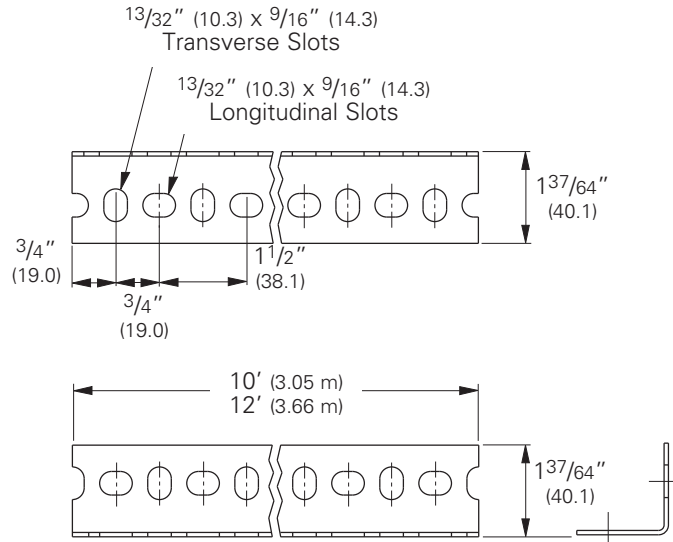
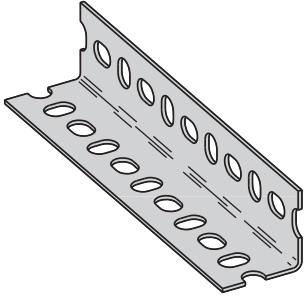

SA276

- 14 Gauge (1.9)
- $1\frac{5}{8}'' \times 2\frac{3}{8}''$
- Standard finishes: ZN, GRN
- Wt./Ft. .78 Lbs. (1.17 kg/m)

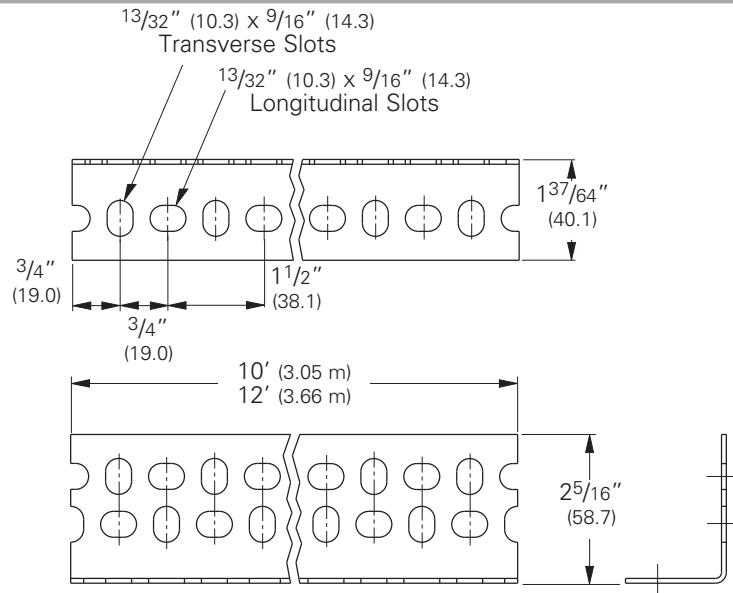
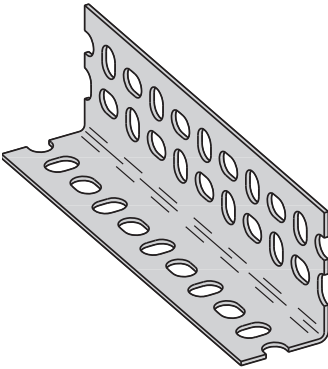

SA318

- 12 Gauge (2.6)
- $1\frac{5}{8}'' \times 3\frac{1}{8}''$
- Standard finishes: ZN, GRN
- Wt./Ft. 1.32 Lbs. (1.96 kg/m)

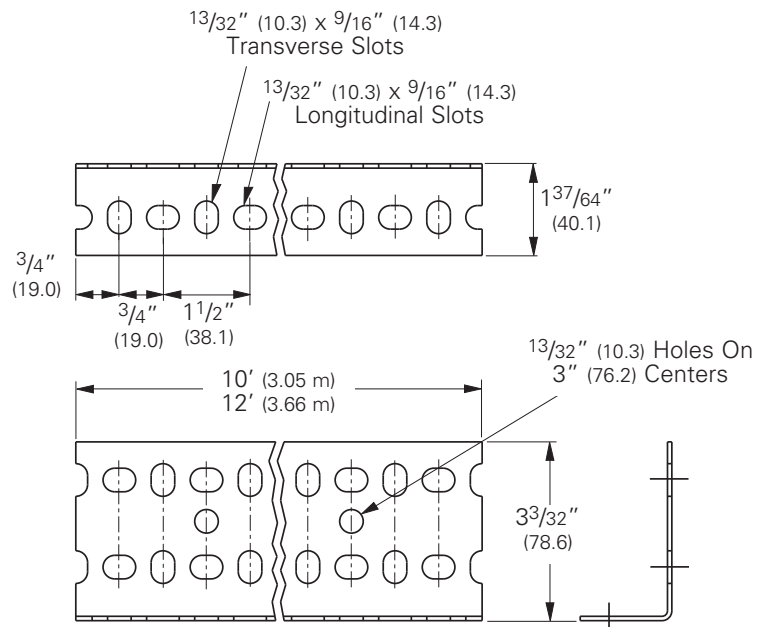
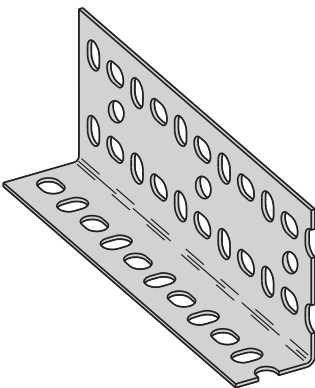

Reference page 264 for general fitting and standard finish specifications.

Slotted Angle Beam Loading & Combinations

Beam Sections

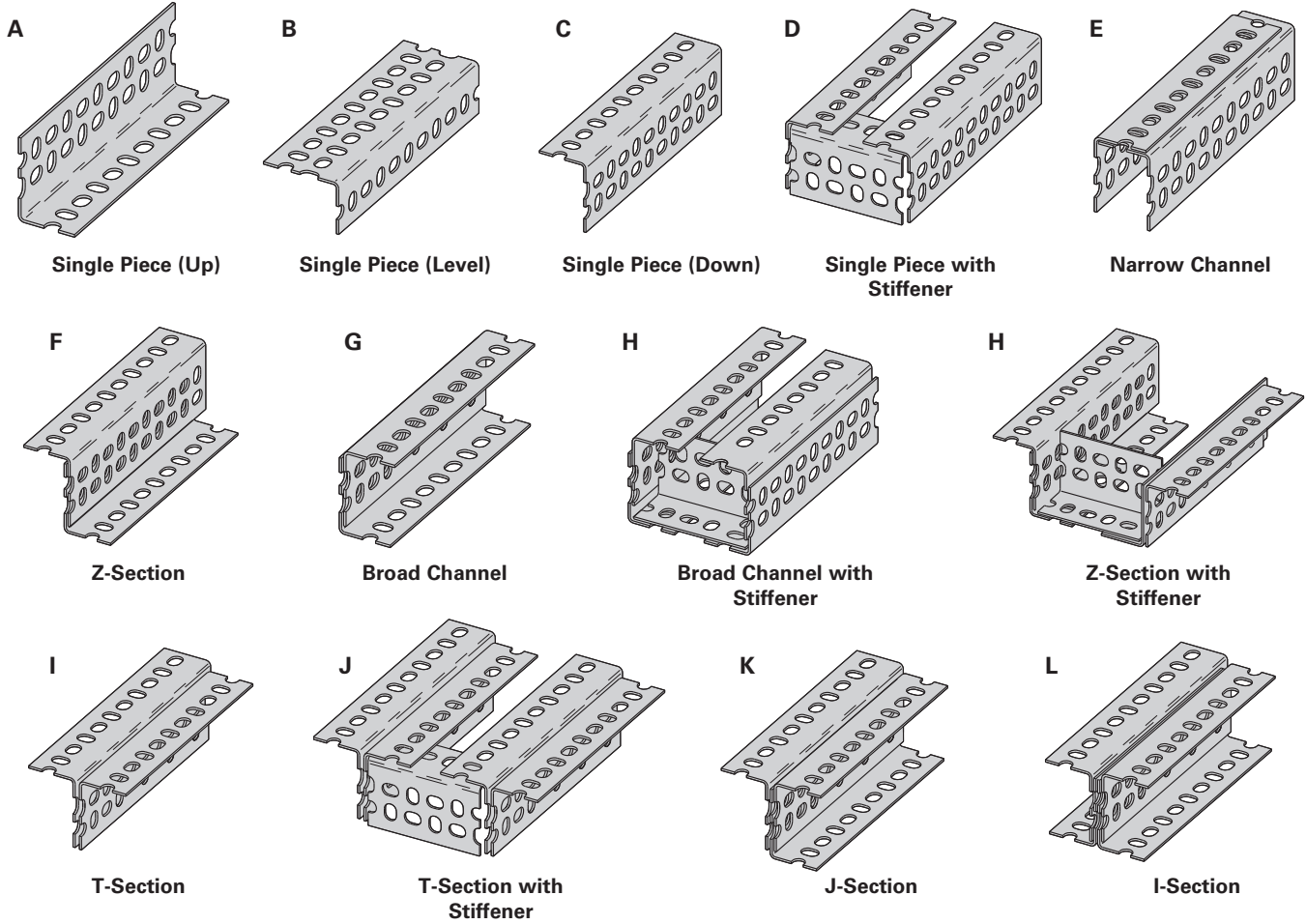

For greater strength required in some applications, Slotted angle may be fastened together to create combination shapes. A number of these combinations are illustrated above. Refer to the following table for load capacities of these combinations.

Beam Sections illustrated are single sections, except J, N, and P.

Beam Loading

SA158-1⁵/₈" (41.3) x 1⁵/₈" (41.3) x 14 Gauge (1.9)

	Beam Span													
	24" (609 mm)		36" (914 mm)		48" (1219 mm)		60" (1524 mm)		72" (1829 mm)		84" (2133 mm)		96" (2438 mm)	
	Lbs.	kN	Lbs.	kN	Lbs.	kN	Lbs.	kN	Lbs.	kN	Lbs.	kN	Lbs.	kN
A	825	(3.67)	525	(2.33)	340	(1.51)	230	(1.02)	180	(0.80)	-	-	-	-
B	1100	(4.89)	800	(3.56)	540	(2.40)	370	(1.64)	250	(1.11)	-	-	-	-
C	1100	(4.89)	800	(3.56)	540	(2.40)	370	(1.64)	250	(1.11)	-	-	-	-
D	1300	(5.78)	900	(4.00)	625	(2.78)	450	(2.00)	330	(1.47)	275	(1.22)	200	(0.89)
G	1900	(8.45)	1360	(6.05)	1050	(4.67)	825	(3.67)	660	(2.93)	530	(2.36)	400	(1.78)
H	2300	(10.23)	1850	(8.23)	1450	(6.45)	1100	(4.89)	950	(4.22)	800	(3.56)	700	(3.11)
I	2200	(9.78)	1650	(7.34)	1225	(5.45)	930	(4.14)	700	(3.11)	550	(2.44)	450	(2.00)

Based on simple beam condition with uniform loads on parallel beams. To determine concentrated load capacity at mid-span, multiply uniform load by 0.5.

Reference page 264 for general fitting and standard finish specifications.

Slotted Angle Beam Loading

Beam Loading

SA276-1⁵/₈" (41.3) x 2³/₈" (60.3) x 14 Gauge (1.9)

	Beam Span																	
	24" (609 mm)		36" (914 mm)		48" (1219 mm)		60" (1524 mm)		72" (1829 mm)		84" (2133 mm)		96" (2438 mm)		108" (2743 mm)		120" (3048 mm)	
	Lbs.	kN	Lbs.	kN	Lbs.	kN	Lbs.	kN	Lbs.	kN	Lbs.	kN	Lbs.	kN	Lbs.	kN	Lbs.	kN
A	–	–	680 (3.02)		450 (2.00)		340 (1.51)		–	–	–	–	–	–	–	–	–	–
B	–	–	830 (3.69)		550 (2.44)		360 (1.60)		210 (0.93)		150 (0.67)		–	–	–	–	–	–
C	–	–	1540 (6.85)		1060 (4.71)		800 (3.56)		610 (2.71)		480 (2.13)		340 (1.51)		250 (1.11)		–	–
D	–	–	1880 (8.36)		1280 (5.69)		970 (4.31)		820 (3.65)		650 (2.89)		550 (2.44)		420 (1.87)		340 (1.51)	
E	–	–	2110 (9.38)		1730 (7.69)		1460 (5.77)		1250 (5.56)		1090 (4.85)		920 (4.09)		820 (3.65)		680 (3.02)	
F	4290 (19.08)		2510 (11.16)		1790 (7.96)		1330 (5.91)		980 (4.36)		710 (3.16)		550 (2.44)		420 (1.87)		320 (1.42)	
G	4320 (19.21)		3000 (13.34)		2140 (9.52)		1600 (7.12)		1290 (5.74)		1040 (4.62)		820 (3.65)		640 (2.85)		490 (2.18)	
H	–	–	3480 (15.48)		2430 (10.81)		1890 (8.41)		1620 (7.20)		1430 (6.36)		1270 (5.65)		1160 (5.16)		1030 (4.58)	
I	5780 (25.71)		3640 (16.19)		2820 (12.54)		2200 (9.78)		1700 (7.56)		1350 (6.00)		1060 (4.71)		850 (3.78)		680 (3.02)	
J	–	–	3660 (16.28)		2840 (12.63)		2230 (9.92)		1720 (7.65)		1360 (6.05)		1090 (4.85)		874 (3.89)		700 (3.11)	
K	–	–	4910 (21.84)		3830 (17.03)		3000 (13.34)		2550 (11.34)		2190 (9.74)		1880 (8.36)		1640 (7.29)		1430 (6.36)	
K	–	–	6360 (28.29)		4590 (20.42)		3470 (15.43)		2910 (12.94)		2550 (11.34)		2240 (9.96)		2010 (8.94)		1840 (8.18)	

Based on simple beam condition with uniform loads on parallel beams. To determine concentrated load capacity at mid-span, multiply uniform load by 0.5.

Beam Loading

SA318-1⁵/₈" (41.3) x 3¹/₈" (79.4) x 12 Gauge (2.6)

	Beam Span																	
	24" (609 mm)		36" (914 mm)		48" (1219 mm)		60" (1524 mm)		72" (1829 mm)		84" (2133 mm)		96" (2438 mm)		108" (2743 mm)		120" (3048 mm)	
	Lbs.	kN	Lbs.	kN	Lbs.	kN	Lbs.	kN	Lbs.	kN	Lbs.	kN	Lbs.	kN	Lbs.	kN	Lbs.	kN
A	–	–	1140 (5.07)		850 (3.78)		690 (3.07)		–	–	–	–	–	–	–	–	–	–
B	–	–	1250 (5.56)		850 (3.78)		600 (2.67)		400 (1.78)		–	–	–	–	–	–	–	–
C	4800 (21.35)		2750 (12.23)		1800 (8.01)		1280 (5.69)		1000 (4.45)		790 (3.51)		610 (2.71)		–	–	–	–
D	–	–	3900 (17.35)		2690 (11.96)		2050 (9.12)		1700 (7.56)		1480 (6.58)		1280 (5.69)		1100 (4.89)		960 (4.27)	
E	–	–	4160 (18.50)		3560 (15.83)		3130 (13.92)		2750 (12.23)		2400 (10.67)		2170 (9.65)		1950 (8.67)		1780 (7.92)	
F	8180 (36.38)		5000 (22.24)		3650 (16.23)		2750 (12.23)		2200 (9.78)		1750 (7.78)		1350 (6.00)		1020 (4.54)		700 (3.11)	
G	10600 (47.15)		6050 (26.91)		4440 (19.75)		3330 (14.81)		2670 (11.88)		2120 (9.43)		1660 (7.38)		1210 (5.38)		1000 (4.45)	
H	–	–	6100 (27.13)		4620 (20.55)		3670 (16.32)		3110 (13.83)		2680 (11.92)		2380 (10.59)		2100 (9.34)		1950 (8.67)	
I	13700 (60.94)		7800 (34.69)		5900 (26.24)		4600 (20.46)		3800 (16.90)		3190 (14.19)		2630 (11.70)		2170 (9.65)		1810 (8.05)	
J	–	–	7900 (35.14)		6300 (28.02)		5050 (22.46)		4070 (18.10)		3240 (14.41)		2630 (11.70)		2170 (9.65)		1810 (8.05)	
K	–	–	10050(44.70)		8000 (35.58)		6320 (28.11)		5350 (23.80)		4650 (20.68)		4040 (17.97)		3520 (15.66)		3120 (13.88)	
K	–	–	12700(56.49)		9550 (42.48)		7540 (33.54)		6540 (29.09)		5730 (25.49)		5030 (22.37)		4520 (20.10)		4000 (17.79)	

Based on simple beam condition with uniform loads on parallel beams. To determine concentrated load capacity at mid-span, multiply uniform load by 0.5.

Reference page 264 for general fitting and standard finish specifications.

Slotted Angle Beam Loading & Combinations

Column Sections

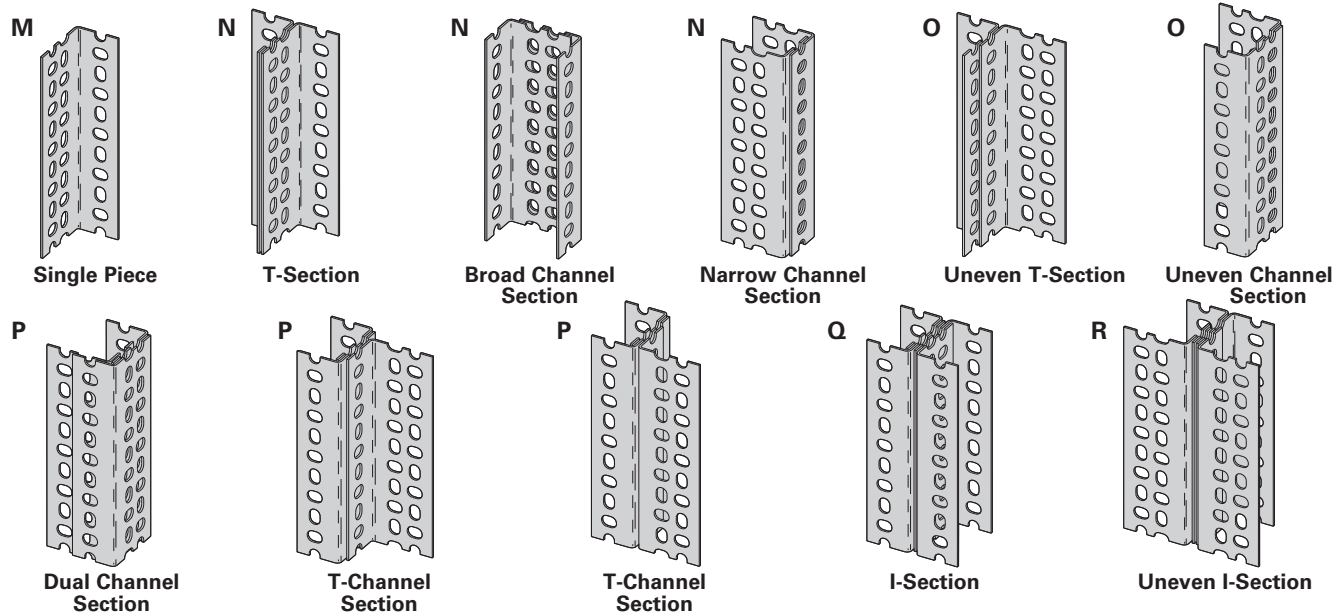

For greater strength required in some applications, Slotted Angle may be fastened together to create combination shapes. A number of these combinations are illustrated above. Refer to the following table for load capacities of these combinations.

Column Loading - SA158-1⁵/₈" (41.3) x 1⁵/₈" (41.3) x 14 Gauge (1.9)

Column Height

	36" (914 mm) Lbs. kN	48" (1219 mm) Lbs. kN	60" (1524 mm) Lbs. kN	72" (1829 mm) Lbs. kN
M	1450 (6.45)	1150 (5.11)	950 (4.22)	750 (3.33)
N	3850 (17.12)	3500 (15.57)	3000 (13.34)	2500 (11.12)

Column Loads assume no lateral support.

Column Loading - SA276-1⁵/₈" (41.3) x 2³/₈" (60.3) x 14 Gauge (1.9)

Column Height

	36" (914 mm) Lbs. kN	48" (1219 mm) Lbs. kN	60" (1524 mm) Lbs. kN	72" (1829 mm) Lbs. kN	84" (2133 mm) Lbs. kN	96" (2438 mm) Lbs. kN	108" (2743 mm) Lbs. kN	120" (3048 mm) Lbs. kN
M	2280 (10.14)	1970 (8.76)	1520 (6.76)	1070 (4.760)	660 (2.93)	- -	- -	- -
N	4760 (21.17)	4490 (19.97)	3995 (17.77)	3140 (13.97)	2340 (10.41)	1750 (7.78)	- -	- -
O	4940 (21.97)	4680 (20.82)	4310 (19.17)	3870 (17.21)	3665 (16.30)	2700 (12.01)	2060 (9.16)	1610 (7.16)
P	7270 (32.34)	6920 (30.78)	6370 (28.33)	5840 (25.98)	4930 (21.93)	3850 (17.12)	2870 (12.76)	2060 (9.16)
Q	9520 (42.35)	8970 (39.90)	7990 (35.54)	6280 (27.93)	4660 (20.73)	3500 (15.57)	- -	- -
R	9865 (43.88)	9330 (41.50)	8620 (38.34)	7715 (34.32)	6740 (29.98)	5365 (23.86)	4115 (18.30)	3210 (14.28)

Column Loads assume no lateral support.

Column Loading - SA318-1⁵/₈" (41.3) x 3¹/₈" (79.4) x 12 Gauge (2.6)

Column Height

	36" (914 mm) Lbs. kN	48" (1219 mm) Lbs. kN	60" (1524 mm) Lbs. kN	72" (1829 mm) Lbs. kN	84" (2133 mm) Lbs. kN	96" (2438 mm) Lbs. kN	108" (2743 mm) Lbs. kN	120" (3048 mm) Lbs. kN
M	3470 (15.43)	2870 (12.76)	1970 (8.76)	1280 (5.69)	- -	- -	- -	- -
N	7970 (35.45)	7360 (32.74)	6570 (29.22)	5270 (23.44)	3670 (16.32)	2580 (11.47)	- -	- -
O	8770 (39.01)	8580 (38.16)	8180 (36.38)	7690 (34.21)	6970 (31.00)	6260 (27.84)	5460 (24.29)	4460 (19.84)
P	12560 (55.87)	11970 (53.24)	11360 (50.53)	10480 (46.62)	9470 (42.12)	8370 (37.23)	6880 (30.60)	5370 (23.89)
Q	15940 (70.90)	14750 (65.61)	13160 (58.54)	10560 (46.97)	7370 (32.78)	5170 (23.00)	- -	- -
R	17550 (78.06)	17150 (76.29)	16360 (72.77)	15360 (68.32)	13970 (62.14)	12570 (55.91)	10970 (48.80)	8960 (39.85)

Column Loads assume no lateral support.

Reference page 264 for general fitting and standard finish specifications.

Slotted Angle Kits & Fittings

AHHK-1/4 & AHHK-3/8 Air Handler Hanging Kit

- Standard finishes: ZN
- Load Capacity Per Kit: 400 Lbs. (181.4 kg)

- ⑧ Hanging rods come in 72" lengths. Rods can be field cut for proper height requirement.

Item #	Description	Quantity	
		AHHK 1/4	AHHK 3/8
①	Rod Hanger Fitting	4	4
②	Lag Screw	4	4
③	Hex Head Cap Screw	4	4
④	Flat Washer (For HHCS)	4	4
⑤	Hex Nuts (For HHCS)	4	4
⑥	Hex Nuts (For Hanging Rods)	16	16
⑦	Flat Washer (See Note 1)	16	-
⑧	Hanging Rods (72" Long)	4	4
⑨	SA158 (36" Long)	2	2

Note 1: Flat washers are required for 1/4"-20 hanging rods only.

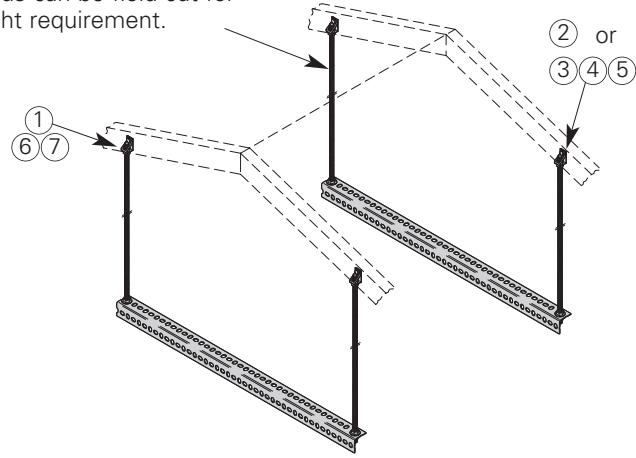

SA101 Connection Plate

- Standard finishes: ZN, GRN
- Wt./C 67 Lbs. (30.4 kg)

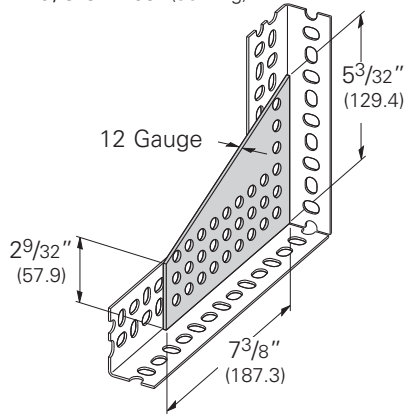

SA102 Angle Brace

- Standard finishes: ZN, GRN
- Wt./C 15 Lbs. (6.8 kg)

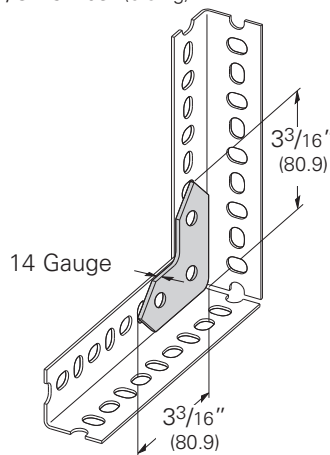

SA154 Rigid Caster

- Safety Factor of 1.5
- 300 Lbs. (136.1 kg) maximum load capacity
- Caster material: Phenolic
- Standard finishes: ZN, GRN
- Wt./Ea. 2.0 Lbs. (.91 kg)

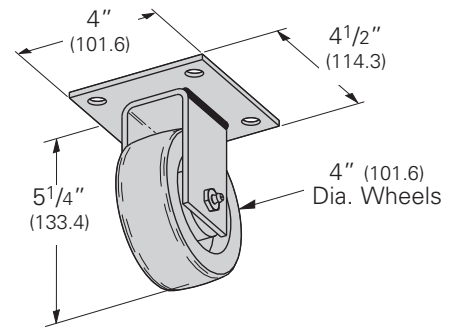

SA155 Swivel Caster

- Safety Factor of 1.5
- 300 Lbs. (136.1 kg) maximum load capacity
- Caster material: Phenolic
- Standard finishes: ZN, GRN
- Wt./Ea. 2.2 Lbs. (1.0 kg)

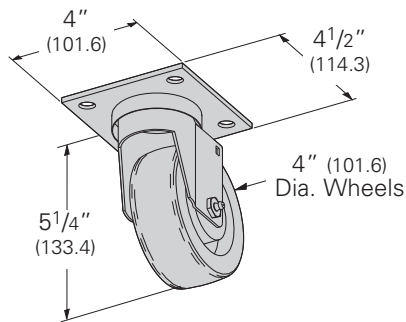

SA110 Slotted Angle Cutter

- Standard finishes:
- Wt./Ea. 16 Lbs. (7.26 kg)

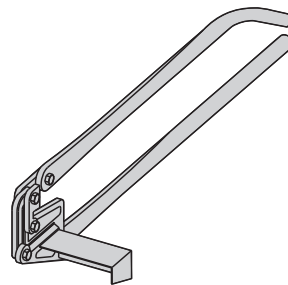

SA131 Slotted Strap

- Hole pattern is identical to the hole pattern in slotted angles
- Standard length: 10' (3.05 m)
- Standard finishes: Pre-Galv. (GALV)
- Material thickness: 14 gauge (1.9)

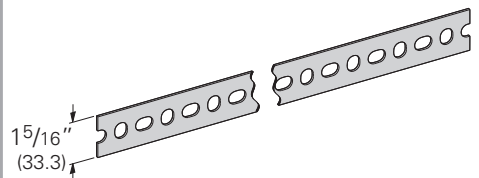

CLEATS: To reinforce load-bearing joints, cleats can be field made by cutting 2 1/4" (57.1) long segments from the widest slotted angle available. Use SA276 for light duty cleats and SA318 for heavy duty cleats.

SPLICE PLATES: To assemble two pieces of slotted angle using a butt joint requires a 6" (152.4) splice plate for reinforcement.

Reference page 264 for general fitting and standard finish specifications.

Reference Data

Metric Conversion Chart

To Convert From	To	Multiply By	To Convert From	To	Multiply By
Angle			Length		
degree	radian (rad)	0.01745329	foot (ft)	meter (m)	0.3048
radian (rad)	degree	57.29578	inch (in)	meter (m)	0.0254
Area			mil	meter (m)	0.0000254
foot ²	square meter (m ²)	0.09290304	inch (in)	millimeter (mm)	25.40000
inch ²	square meter (m ²)	0.00064516	inch (in)	micrometer (µm)	25400.00
circular mil	square meter (m ²)	0.0000000005067075	millimeter (mm)	inch (in)	0.0393701
sq. centimeter (cm ²)	square inch (in ²)	0.1550003	meter (m)	foot (ft)	3.280840
square meter (m ²)	foot ²	10.76391	meter (m)	inch (in)	39.37008
square meter (m ²)	inch ²	1550.003	meter (m)	mil	39370.08
square meter (m ²)	circular mil	1973523000.0	micrometer (µm)	inch (in)	0.00003937008
Temperature			Volume		
degree Fahrenheit	degree Celsius	$t^{°C} = (t^{°F} - 32) / 1.8$	foot ³	cubic meter (m ³)	0.02831685
degree Celsius	degree Fahrenheit	$t^{°F} = 1.8t^{°C} + 32$	inch ³	cubic meter (m ³)	0.00001638706
Force			cubic centimeter (cm ³)	cubic inch (in ³)	0.06102374
pounds-force (lbf)	newtons (N)	4.448222	cubic meter (m ³)	foot ³	35.31466
			cubic meter (m ³)	inch ³	61023.76
			gallon (U.S. liquid)	cubic meter (m ³)	0.003785412
			Section Properties		
			section modulus S (in ³)	S (m ³)	0.00001638706
			moment of inertia I (in ⁴)	I (m ⁴)	0.0000004162314
			modulus of elasticity E (psi)	E (Pa)	6894.757
			section modulus S (m ³)	S (in ³)	61023.74
			moment of inertia I (m ⁴)	I (in ⁴)	2402510.0
			modulus of elasticity E (Pa)	E (psi)	0.0001450377

To Convert From	To	Multiply By
Bending Moment or Torque		
lbf • ft	newton meter (N•m)	1.355818
lbf • in	newton meter (N•m)	0.1129848
N•m	lbf • ft	0.7375621
N•m	lbf • in	8.850748
Mass		
ounce (avoirdupois)	kilogram (kg)	0.02834952
pound (avoirdupois)	kilogram (kg)	0.4535924
ton (short, 2000 lb)	kilogram (kg)	907.1847
ton (long, 2240 lb)	kilogram (kg)	1016.047
kilogram (kg)	ounce (avoirdupois)	35.27396
kilogram (kg)	pound (avoirdupois)	2.204622
kilogram (kg)	ton (short, 2000 lb)	0.001102311
kilogram (kg)	ton (long, 2240 lb)	0.0009842064
Mass Per Unit Length		
lb/ft	kilogram per meter (kg/m)	1.488164
lb/in	kilogram per meter (kg/m)	17.85797
kg/m	lb/ft	0.6719689
kg/m	lb/in	0.5599741
Mass Per Unit Volume		
lb/ft ³	kilogram per cubic meter (kg/m ³)	16.01846
lb/in ³	kilogram per cubic meter (kg/m ³)	27679.9
kg/m ³	lb/ft ³	0.06242797
kg/m ³	lb/in ³	0.0000361273
lbs/ft ³	lbs/in ³	1728.0
Mass Per Unit Area		
lb/ft ²	kilogram per square meter (kg/m ²)	4.882428
kg/m ²	pound per square foot (lb/ft ²)	0.2048161
Pressure or Stress		
lbf/in ² (psi)	pascal (Pa)	6894.757
kip/in ² (ksi)	pascal (Pa)	6894757.0
lbf/in ² (psi)	megapascals (MPa)	0.006894757
pascal (Pa)	pound-force per square inch (psi)	0.0001450377
pascal (Pa)	kip per square inch (ksi)	0.0000001450377
megapascals (MPa)	lbf/in ² (psi)	145.0377

Abbreviations
Defl. = Deflection
S.F. = Safety Factor
Ft. = Feet
Pre-galv. = Pre-galvanized Steel
K Factor = Deflection ÷ load in Lbs./Ft.
o.c. = On Center
PVC = Poly Vinyl Chloride
In. = Inch
psi = Pounds per Square Inch
wt./c = Weight per 100 pieces

Metric Symbols
m = meter
cm = centimeter
mm = millimeter
µm = micrometer
kg = kilogram
N = newton
kN = kilonewton
Pa = pascal
MPa = megapascal

Design Load Data (For typical channel-fitting connections when USED IN PAIRS).

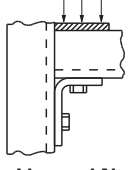
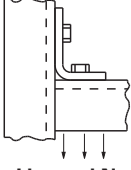
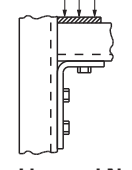
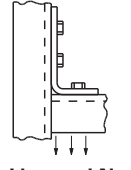
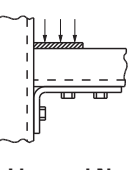
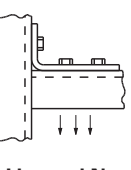
Channel Thickness	90° Fittings											
												
	Lbs.	kN	Lbs.	kN	Lbs.	kN	Lbs.	kN	Lbs.	kN	Lbs.	kN
12 ga. (2.6)	1500	(6.67)	1000	(4.45)	2000	(8.90)	1500	(6.67)	1500	(6.67)	1000	(4.45)
14 ga. (1.9)	1000	(4.45)	650	(2.89)	1500	(6.67)	1150	(5.12)	1000	(4.45)	650	(2.89)
16 ga. (1.5)	750	(3.34)	500	(2.22)	900	(4.00)	650	(2.89)	1000	(4.45)	500	(2.22)

Design load data includes a safety factor of 2.5 (safety factor = ratio of ultimate load to design load).

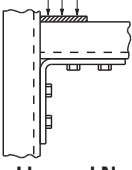
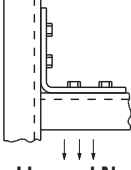
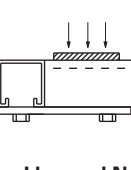
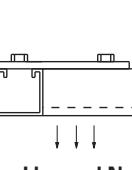
Channel Thickness	90° Fittings				Flat Fittings							
												
	Lbs.	kN	Lbs.	kN	Lbs.	kN	Lbs.	kN				
12 ga. (2.6)	2500	(11.12)	2000	(8.90)	3000	(13.34)	2500	(11.12)	1000	(4.45)	1000	(4.45)
14 ga. (1.9)	2000	(8.90)	1650	(7.34)	2000	(8.90)	1650	(7.34)	800	(3.56)	800	(3.56)
16 ga. (1.5)	1500	(6.67)	1250	(5.56)	1500	(6.67)	1250	(5.56)	600	(2.67)	600	(2.67)

Reference Data

General Notes for Strut-Type Channel Raceway

UL Category RIUU - Cooper B-Line, Inc. (DBA Eaton), Highland, IL 62249 December 11, 1998 (C)  File No. E29637
FLUORESCENT AND INCANDESCENT LIGHTING

Suitable for not more than the number of wires of the sizes and types indicated in the following tables. Intended to enclose circuits operating at potentials not exceeding 600 volts between conductors. In all cases, the B217-20 or B217P snap-in cover is required to complete raceway closure. When using B217-24 snap-in cover, the number of wires is limited to 7 or fewer conductors no larger than #12 AWG.

Eaton's B-Line series strut-type channel raceways and fittings are manufactured and tested to comply with the UL Standard for Safety for Strut-Type Channel Raceways and Fittings (UL 5B) in accordance with Article 384 of the 2002 National Electrical Code, NFPA 70.

1. Support spans for strut-type channel raceway shall not exceed 10 foot intervals.
2. No conductor larger than that for which the raceway is listed shall be installed in strut-type channel raceways. No wires under 14AWG or over 6AWG are allowed in any strut-type channel raceway. See tables 1, 2, and 3 (on pages 231 & 232) for a listing of the approved conductors for strut-type channel raceways.
3. The number of conductors permitted in strut-type channel raceway shall not exceed the percentage fill using Table 384-22 and the applicable outside diameter of specific types and sizes of wire given in the tables in chapter 9 of the National Electrical Code. Table 384-22 lists two different percent fill areas depending on the use of internal or external joiners. Use 40% area fill with external joiners and 25% area fill for internal joiners.
4. Items in the electrical section of Eaton's B-Line Business' Strut Systems Catalog identified by the UL symbol provide for electrical continuity. Other items require the use of a separate grounding wire.
5. If strut-type channel raceway is connected to another wiring system, the raceway must be field-tapped adjacent to the wire entry point to accept a #10-32 or larger grounding screw. A plated or stainless steel screw may be used. A sheet metal screw is not acceptable. Drill and tap the grounding wire hole before installing wires in raceway or move installed wires out of the way to avoid damage. After drilling and tapping, remove metal chips and burrs before installing screw.

TABLE 1: MAXIMUM NUMBER OF WIRES (Adjusted per NEC Table 384.22 for 40% fill)

Use this table to determine the type and number of conductors for use with B-Line series strut-type channel raceway using external joiners. This table applies for all installations except for the support and supply of electric discharge type lighting fixtures. See table 2 and 3 for further information.

Table 1 applies to steel and aluminum cover strips; contact B-Line or reference website for plastic closure strip informa-

Insulation Type	Wire Size AWG.	B11 B11K06	B12 B12K06	B22 B22K06	B24 B24K06	B32 B32K06
FEP, FEPB	14	172	127	81	81	67
	12	126	92	59	59	49
	10	90	66	42	42	35
	8	51	38	24	24	20
	6	24	17	11	12	9
RH, RHH, RHW	14	52	38	24	26	20
	12	45	33	21	22	17
	10	37	27	17	18	14
	8	20	14	9	10	7
	6	14	10	6	7	5
T, TW	14	124	91	58	58	48
	12	95	70	45	45	37
	10	69	51	33	33	27
	8	36	26	17	18	14
	6	21	15	9	10	8
THHN, THWN	14	178	131	84	84	69
	12	130	95	61	61	50
	10	82	60	38	38	32
	8	46	34	21	22	17
	6	33	24	15	16	12
THW	14	82	61	39	39	32
	12	66	49	31	31	26
	10	52	38	24	24	20
	8	29	21	13	14	11
	6	21	15	10	10	8
XHHW	14	124	91	58	58	48
	12	95	70	45	45	37
	10	71	52	33	33	28
	8	37	27	17	19	14
	6	27	20	13	14	10

Table 2: Maximum Number of Wires

Also suitable for the number of wires in table below when installed to support and supply *electric discharge type lighting fixtures* when raceway wiring is suitable for at least **70°C and clearance between fixture and raceway is at least 1/8"**. In all cases, a snap-in cover is required to complete the raceway enclosure.

Wire Size	Raceway Catalog Wires				
	B11 B11K06	B12 B12K06	B22 B22K06	B24 B24K06	B32 B32K06
Type Insulation: FEP, FEPB, RH, RHH, RHW, RUH, THHN, THWN, THW, XHHW					
14	13	10	10	10	10
12	13	10	10	10	10
10	13	10	8	8	6
8	10	8	6	6	4
6	8	6	4	4	3

When using B217-24 snap-in cover, the number of wires is limited to 7 or fewer conductors no larger than #12 AWG.

Table 3: Maximum Number of Wires







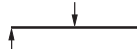

Also suitable for the number of wires in table below when installed to support and supply *electric discharge type lighting fixtures* when raceway wiring is suitable for 75°C, **or** wiring suitable for 60°C **if a minimum clearance between fixture and raceway is at least 1/2"**. In all cases, a snap-in cover is required to complete the raceway enclosure.

Wire Size	Raceway Catalog Wires				
	B11 B11K06	B12 B12K06	B22 B22K06	B24 B24K06	B32 B32K06
Type Insulation: FEP, FEPB, RH, RHH, RHW, RUH, THHN, THWN, THW, XHHW					
14	10	10	10	10	10
12	10	10	10	10	10
10	8	5	5	5	5
8	6	4	4	4	4
6	4	4	4	4	4

When using B217-24 snap-in cover, the number of wires is limited to 7 or fewer conductors no larger than #12 AWG.

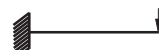
Reference Data

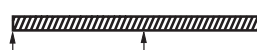
The data shown in the beam load charts for appropriate channels on page(s) 50 thru 73 is for simply supported, single span beams with a uniformly distributed load. For other loading and/or support conditions, use the appropriate factor from the chart below.

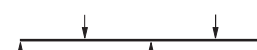
Load and Support Condition		Load Factor	Deflection Factor
Simple Beam - Uniform Load		1.00	1.00
Simple Beam - Concentrated Load at Center		.50	.80
Simple Beam - Two Equal Concentrated Loads at 1/4 Points		1.00	1.10
Beam Fixed at Both Ends - Uniform Load		1.50	.30
Beam Fixed at Both Ends - Concentrated Load at Center		1.00	.40
Cantilever Beam - Uniform Load		.25	2.40
Cantilever Beam - Concentrated Load at End		.12	3.20
Continuous Beam - Two Equal Spans - Uniform Load on One Span		1.30	.92
Continuous Beam - Two Equal Spans - Concentrated Load on Both Spans		1.00	.42
Continuous Beam - Two Equal Spans - Concentrated Load at Center of One Span		.62	.71
Continuous Beam - Two Equal Spans - Concentrated Load at Center of Both Spans		.67	.48

EXAMPLES:

PROBLEM:

Calculate the maximum allowable load and corresponding deflection of a simply supported B22 beam with a concentrated load at midspan as shown.

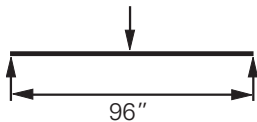

SOLUTION:

From beam load chart for B22 (page 56), maximum allowable load is A and the corresponding deflection is B. Multiplying by the appropriate factors shown in the chart above.

LOAD = A x load factor = _____
 DEFLECTION = B x deflection factor = _____

PROBLEM:

Calculate the maximum allowable load and corresponding deflection of a cantilever B52 beam with a uniformly distributed load.



SOLUTION:

From beam load chart for B52 (page 67), maximum allowable load is A and the corresponding deflection is B. Multiplying by the appropriate factors shown in chart above.

LOAD = A x load factor = _____
 DEFLECTION = B x deflection factor = _____

Rigid Steel Conduit (Heavy Wall Conduit)

Nominal Conduit Size		Outside Diameter		Nominal Inside Diameter		Minimum Weight Per 100 Ft. (30.5m) with Couplings Attached		Weight of Conduit and Conductors Per 100 Ft. (30.5m)*	
In.	mm	In.	mm	In.	mm	Lbs.	kg	Lbs.	kg
3/8"	(10)	0.675	(17.1)	0.493	(12.5)	51.5	(23.4)	65.1	(29.5)
1/2"	(15)	0.840	(21.3)	0.632	(16.0)	79.0	(35.8)	101.1	(45.9)
3/4"	(20)	1.050	(26.7)	0.836	(21.3)	105.0	(47.6)	145.8	(66.1)
1"	(25)	1.315	(33.4)	1.063	(27.0)	153.0	(69.4)	219.3	(99.5)
1 1/4"	(32)	1.660	(42.2)	1.394	(35.4)	201.0	(91.2)	318.3	(144.4)
1 1/2"	(40)	1.900	(48.3)	1.624	(41.3)	249.0	(113.0)	408.8	(185.4)
2"	(50)	2.375	(60.3)	2.083	(52.9)	332.0	(150.6)	593.8	(269.3)
2 1/2"	(65)	2.875	(73.0)	2.489	(63.2)	527.0	(239.1)	901.0	(408.7)
3"	(80)	3.500	(88.9)	3.090	(78.5)	682.6	(309.6)	1259.0	(571.1)
3 1/2"	(90)	4.000	(101.6)	3.570	(90.7)	831.0	(376.9)	1604.0	(727.6)
4"	(100)	4.500	(114.3)	4.050	(102.9)	972.3	(441.0)	1967.0	(892.2)
5"	(125)	5.563	(141.3)	5.073	(128.9)	1313.6	(595.9)	2876.0	(1304.5)
6"	(150)	6.625	(168.3)	6.093	(154.8)	1745.3	(791.7)	4003.0	(1815.7)

Dimensions taken from ANSI C80.1-1977.

*Conduit plus weight of heaviest conductor combination as specified by the National Electrical Code.

Intermediate Metal Conduit (IMC)

Nominal Conduit Size		Outside Diameter		Nominal Inside Diameter		Minimum Weight Per 100 Ft. (30.5m) with Couplings Attached		Weight of Conduit and Conductors Per 100 Ft. (30.5m)*	
In.	mm	In.	mm	In.	mm	Lbs.	kg	Lbs.	kg
1/2"	(15)	0.815	(20.7)	.675	(17.1)	60.0	(27.2)	82.1	(37.2)
3/4"	(20)	1.029	(26.1)	.879	(22.3)	82.0	(37.2)	122.8	(55.7)
1"	(25)	1.290	(32.7)	1.120	(28.4)	116.0	(52.6)	182.3	(82.7)
1 1/4"	(32)	1.638	(41.6)	1.468	(37.3)	150.0	(68.0)	267.3	(121.2)
1 1/2"	(40)	1.883	(47.7)	1.703	(43.3)	182.0	(82.5)	341.8	(155.0)
2"	(50)	2.360	(59.9)	2.170	(55.1)	242.0	(109.7)	503.8	(228.5)
2 1/2"	(65)	2.857	(72.5)	2.597	(66.0)	428.0	(194.1)	775.0	(351.5)
3"	(80)	3.476	(88.3)	3.216	(81.7)	526.0	(238.6)	1069.0	(485.0)
3 1/2"	(90)	3.971	(100.8)	3.711	(94.3)	612.0	(277.6)	1346.0	(610.8)
4"	(100)	4.466	(113.4)	4.206	(106.8)	682.0	(309.4)	1632.0	(740.5)

*Conduit plus weight of heaviest conductor combination as specified by the National Electrical Code.

Rigid and Intermediate Metal Conduit shall be supported at least every 10 feet (3.05 m) and within 3 feet (914 mm) of each outlet box, junction box, cabinet, or fitting, except for straight runs of conduit connected with couplings which may be supported in accordance with NEC Article 345 and 346, provided such supports prevent transmission of stresses to termination where conduit is deflected between supports.

NEC Table 346-12

Conduit Size	In.	mm	Maximum Support Span	
			Feet	Meters
1/2 - 3/4	(15 - 20)		10	(3.05)
1	(25)		12	(3.66)
1 1/4 - 1 1/2	(32 - 40)		14	(4.27)
2 - 2 1/2	(50 - 65)		16	(4.88)
3 - 6	(80 - 150)		20	(6.10)

Reference Data

Electrical Metallic Tubing (EMT) – Thinwall Conduit

Nominal Conduit Size		Outside Diameter		Inside Diameter		Weight Per 100 Ft. (30.5m) with		Weight of Conduit and Conductors Per 100 Ft. (30.5m)*	
						Lbs.	kg	Lbs.	kg
In.	mm	In.	mm	In.	mm				
3/8"	(10)	0.577	(14.7)	0.493	(12.5)	23.0	(10.4)	36.6	(16.6)
1/2"	(15)	0.706	(17.9)	0.622	(15.8)	28.5	(12.9)	50.6	(23.0)
3/4"	(20)	0.922	(23.4)	0.824	(20.9)	43.5	(19.7)	84.3	(38.2)
1"	(25)	1.163	(29.5)	1.049	(26.6)	64.0	(29.0)	130.3	(59.1)
1 1/4"	(32)	1.510	(38.3)	1.380	(35.1)	95.0	(43.1)	212.3	(96.3)
1 1/2"	(40)	1.740	(44.2)	1.610	(40.9)	110.0	(49.9)	269.8	(122.4)
2"	(50)	2.197	(55.8)	2.067	(52.5)	140.0	(63.5)	401.8	(182.3)
2 1/2"	(65)	2.875	(73.0)	2.731	(69.4)	205.0	(93.0)	579.0	(262.6)
3"	(80)	3.500	(88.9)	3.356	(85.2)	250.0	(113.4)	826.3	(374.8)
3 1/2"	(90)	4.000	(101.6)	3.834	(97.4)	325.0	(147.4)	1098.0	(498.0)
4"	(100)	4.500	(114.3)	4.334	(110.1)	370.0	(167.8)	1364.0	(618.7)

Dimensions taken from ANSI C80.3-1977.

*Conduit plus weight of heaviest conductor combination as specified by the National Electrical Code.

Electrical Metallic tubing shall be supported at least every 10 feet (3.05 m) and within 3 feet (914 mm) of each outlet box, junction box, cabinet, or fitting. See NEC Article 348.

Rigid Aluminum Conduit

Nominal Conduit Size		Outside Diameter		Nominal Inside Diameter		Minimum Weight Per 100 Ft. (30.5m) with Couplings Attached		Weight of Conduit and Conductors Per 100 Ft. (30.5m)*	
						Lbs.	kg	Lbs.	kg
In.	mm	In.	mm	In.	mm				
1/2"	(15)	0.840	(21.3)	0.632	(16.1)	27.4	(12.4)	49.5	(22.5)
3/4"	(20)	1.050	(26.7)	0.836	(21.2)	36.4	(16.5)	77.2	(35.0)
1"	(25)	1.315	(33.4)	1.063	(27.0)	53.0	(24.0)	119.3	(54.1)
1 1/4"	(32)	1.660	(42.2)	1.394	(35.4)	69.6	(31.6)	186.9	(84.8)
1 1/2"	(40)	1.900	(48.3)	1.624	(41.2)	82.2	(37.3)	242.0	(109.8)
2"	(50)	2.375	(60.3)	2.083	(52.9)	115.7	(52.5)	377.5	(171.2)
2 1/2"	(65)	2.875	(73.0)	2.489	(63.2)	182.5	(82.8)	556.5	(252.4)
3"	(80)	3.500	(88.9)	3.090	(78.5)	238.9	(108.4)	815.2	(369.8)
3 1/2"	(90)	4.000	(101.6)	3.570	(90.7)	287.7	(130.5)	1061.0	(481.3)
4"	(100)	4.500	(114.3)	4.050	(102.9)	340.0	(154.2)	1334.0	(605.1)
5"	(125)	5.563	(141.3)	5.073	(128.9)	465.4	(211.1)	2028.0	(919.9)
6"	(150)	6.625	(168.3)	6.093	(154.8)	612.5	(277.8)	2870.0	(1301.8)

Dimensions taken from ANSI C80.5-1977.

*Conduit plus weight of heaviest conductor combination as specified by the National Electrical Code.

Aluminum Rigid Conduit shall be supported at least every 10 feet (3.05 m) and within 3 feet (914 mm) of each outlet box, junction box, cabinet, or fitting, except for straight runs of conduit connected with couplings which may be supported in accordance with NEC Table 344.30 (B)(2), provided such supports prevent transmission of stresses to termination where

NEC TABLE 344.30 (B)(2)

Conduit Size		Maximum Support Span	
In.	mm	Feet	Meters
1/2 - 3/4	(15 - 20)	10	(3.05)
1	(25)	12	(3.66)
1 1/4 - 1 1/2	(32 - 40)	14	(4.27)
2 - 2 1/2	(50 - 65)	16	(4.88)
3 - 6	(80 - 150)	20	(6.10)

SCHEDULE 40 PVC PLASTIC PIPE

Nominal Conduit Size		Outside Diameter		Inside Diameter		Weight of Pipe Per 100 Ft. (30.5m)		Weight of Pipe Filled With Water Per 100 Ft. (30.5m)	
In.	mm	In.	mm	In.	mm	Lbs.	kg	Lbs.	kg
1/8"	(3)	.405	(10.3)	.269	(6.8)	4.7	(2.1)	7.2	(3.2)
1/4"	(6)	.540	(13.7)	.364	(9.2)	8.2	(3.7)	12.7	(5.8)
3/8"	(10)	.675	(17.1)	.493	(12.5)	10.9	(4.9)	19.2	(8.7)
1/2"	(15)	.840	(21.3)	.622	(15.8)	16.4	(7.4)	29.6	(13.4)
3/4"	(20)	1.050	(26.7)	.824	(20.9)	21.8	(9.9)	44.9	(20.4)
1"	(25)	1.315	(33.4)	1.049	(26.6)	32.1	(14.6)	69.6	(31.6)
1 1/4"	(32)	1.660	(42.2)	1.380	(35.1)	43.4	(19.7)	108.2	(49.1)
1 1/2"	(40)	1.900	(48.3)	1.610	(40.9)	51.8	(23.5)	140.0	(63.5)
2"	(50)	2.375	(60.3)	2.067	(52.5)	69.5	(31.5)	214.9	(97.5)
2 1/2"	(65)	2.875	(73.0)	2.469	(62.7)	109.6	(49.7)	317.1	(143.8)
3"	(80)	3.500	(88.9)	3.068	(77.9)	143.5	(65.1)	463.9	(210.4)
3 1/2"	(90)	4.000	(101.6)	3.548	(90.1)	175.6	(79.7)	604.1	(274.0)
4"	(100)	4.500	(114.3)	4.026	(102.3)	204.3	(92.7)	756.0	(342.9)
5"	(125)	5.563	(141.3)	5.047	(128.2)	281.7	(127.8)	1148.8	(521.1)
6"	(150)	6.625	(168.3)	6.065	(154.1)	360.9	(163.7)	1613.0	(731.7)
8"	(200)	8.625	(219.1)	7.981	(202.7)	545.3	(247.3)	2713.5	(1230.8)
10"	(250)	10.750	(273.1)	10.020	(254.5)	791.3	(358.9)	4208.9	(1909.1)
12"	(300)	12.750	(323.9)	11.938	(303.2)	1035.2	(469.6)	5886.4	(2670.0)

1 cubic ft. of water weighs 62.41 Lbs.
 1 cubic meter of water weighs 999.972 kg.
 1 gallon (U.S.) weighs 8.335 Lbs.
 1 liter weighs .999 kg.

Clamp Sizing Chart For PVC Coated Rigid Conduit and Clamps

Nominal Conduit Size	Conduit Coating			
	.020 (.51mm) Clamp Coating		.040 (1.01mm) Clamp Coating	
	0	.020 (.51mm)	0	.020 (.51mm)
1/2" (15)	B2028	B2002	B2002	B2029
3/4" (20)	B2030	B2030	B2030	B2003
1" (25)	B2032	B2032	B2032	B2033
1 1/4" (32)	B2005	B2005	B2005	B2005
1 1/2" (40)	B2012	B2037	B2037	B2037
2" (50)	B2013	B2041	B2041	B2041
2 1/2" (65)	B2014	B2045	B2045	B2045
3" (80)	B2015	B2050	B2050	B2050
3 1/2" (90)	B2016	B2054	B2054	B2054
4" (100)	B2017	B2058	B2058	B2058
5" (125)	B2019	B2066	B2066	B2066
6" (150)	B2020	B2115	B2115	B2115

All Threaded Rod (ATR)

Nominal Size (In) and Thread	Root Area		Design Load (SF=5)	
	In. ²	cm ²	Lbs.	kN
1/4-20"	0.027	(0.174)	240	(1.07)
5/16-18"	0.045	(0.290)	400	(1.78)
3/8-16"	0.068	(0.438)	730	(3.24)
1/2-13"	0.126	(0.812)	1350	(6.00)
5/8-11"	0.202	(1.303)	2160	(9.60)
3/4-10"	0.302	(1.948)	3230	(14.37)
7/8-9"	0.419	(2.703)	4480	(19.93)
1-8"	0.551	(3.561)	5900	(26.24)
1 1/8-7"	0.693	(4.471)	7450	(33.14)
1 1/4-7"	0.889	(5.735)	9500	(42.25)
1 1/2-6"	1.293	(8.342)	13800	(61.38)

Dimensions taken from ANSI B1.1-1982 Unified Inch Screw Threads. All threads are UNCR series.

Tabulated loads are based on an allowable tensile stress of 12000 psi (82.7 MPa) reduced by 25% resulting in 9000 psi (62 MPa). From ANSI/MSS SP-58, Table 3.

Clamp Sizing Chart For PVC Coated Thinwall (EMT) Conduit and Clamps

Nominal Conduit Size	Conduit Coating			
	.020 (.51mm) Clamp Coating		.040 (1.01mm) Clamp Coating	
	0	.020 (.51mm)	0	.020 (.51mm)
3/8" (10)	B2026	B2026	B2026	B2007
1/2" (15)	B2027	B2027	B2027	B2008
3/4" (20)	B2029	B2029	B2029	B2009
1" (25)	B2003	B2031	B2031	B2031
1 1/4" (32)	B2004	B2034	B2034	B2034
1 1/2" (40)	B2035	B2035	B2035	B2036
2" (50)	B2039	B2039	B2039	B2013

Reference Data

Copper Tubing, Type L

Nominal Tubing Size		Outside Diameter		Inside Diameter		Weight of Tubing Per 100 Ft. (30.5m)		Weight of Tubing Filled With Water Per 100 Ft. (30.5m)	
In.	mm	In.	mm	In.	mm	Lbs.	kg	Lbs.	kg
1/4"	(6)	.375	(9.5)	.315	(8.0)	12.6	(5.7)	16.0	(7.2)
3/8"	(10)	.500	(12.7)	.430	(10.9)	19.8	(9.0)	26.1	(11.8)
1/2"	(15)	.625	(15.9)	.545	(13.8)	28.5	(12.9)	38.6	(17.5)
5/8"	(17)	.750	(19.1)	.666	(16.9)	36.2	(16.4)	51.3	(23.3)
3/4"	(20)	.875	(22.2)	.785	(19.9)	45.5	(20.6)	66.5	(30.2)
1"	(25)	1.125	(28.6)	1.025	(26.0)	65.5	(29.7)	101.3	(45.9)
1 1/4"	(32)	1.375	(34.9)	1.265	(32.1)	88.4	(40.1)	142.9	(64.8)
1 1/2"	(40)	1.625	(41.3)	1.505	(38.2)	114.0	(51.7)	191.1	(86.7)
2"	(50)	2.125	(54.0)	1.985	(50.4)	175.0	(79.4)	309.1	(140.2)
2 1/2"	(65)	2.625	(66.7)	2.465	(62.6)	248.0	(112.5)	454.8	(206.3)
3"	(80)	3.125	(79.4)	2.945	(74.8)	333.0	(151.0)	628.2	(285.0)
3 1/2"	(90)	3.625	(92.1)	3.425	(87.0)	429.0	(194.6)	828.3	(375.7)
4"	(100)	4.125	(104.8)	3.905	(99.2)	538.0	(244.0)	1057.1	(479.5)
5"	(125)	5.125	(130.2)	4.875	(123.8)	761.0	(345.2)	1570.0	(712.1)
6"	(150)	6.125	(155.6)	5.845	(148.5)	1020.0	(462.7)	2182.9	(990.2)
8"	(200)	8.125	(206.4)	7.725	(196.2)	1930.0	(875.4)	3961.3	(1796.8)
10"	(250)	10.125	(257.2)	9.625	(244.5)	3010.0	(1365.3)	6163.4	(2795.7)
12"	(300)	12.125	(308.0)	11.565	(293.8)	4040.0	(1832.5)	8592.8	(3897.6)

Copper Tubing, Type K

Nominal Tubing Size		Outside Diameter		Inside Diameter		Weight of Tubing Per 100 Ft. (30.5m)		Weight of Tubing Filled With Water Per 100 Ft. (30.5m)	
In.	mm	In.	mm	In.	mm	Lbs.	kg	Lbs.	kg
1/4"	(6)	.375	(9.5)	.305	(7.7)	14.5	(6.6)	17.7	(8.0)
3/8"	(10)	.500	(12.7)	.402	(10.2)	26.9	(12.2)	32.4	(14.7)
1/2"	(15)	.625	(15.9)	.527	(13.4)	34.4	(15.6)	43.9	(19.9)
5/8"	(17)	.750	(19.1)	.652	(16.6)	41.8	(19.0)	56.3	(25.5)
3/4"	(20)	.875	(22.2)	.745	(18.9)	64.1	(29.1)	83.0	(37.6)
1"	(25)	1.125	(28.6)	.995	(25.3)	83.9	(38.1)	117.6	(53.3)
1 1/4"	(32)	1.375	(34.9)	1.245	(31.6)	104.0	(47.2)	156.8	(71.1)
1 1/2"	(40)	1.625	(41.3)	1.481	(37.6)	136.0	(61.7)	210.7	(95.6)
2"	(50)	2.125	(54.0)	1.959	(49.8)	206.0	(93.4)	336.6	(152.7)
2 1/2"	(65)	2.625	(66.7)	2.435	(61.8)	293.0	(132.9)	494.8	(224.5)
3"	(80)	3.125	(79.4)	2.907	(73.8)	400.0	(181.4)	687.7	(311.9)
3 1/2"	(90)	3.625	(92.1)	3.385	(86.0)	512.0	(232.2)	902.0	(409.2)
4"	(100)	4.125	(104.8)	3.857	(98.0)	651.0	(295.3)	1157.4	(525.0)
5"	(125)	5.125	(130.2)	4.805	(122.0)	967.0	(438.6)	1752.9	(795.1)
6"	(150)	6.125	(155.6)	5.741	(145.8)	1390.0	(630.5)	2511.9	(1139.4)
8"	(200)	8.125	(206.4)	7.583	(192.6)	2590.0	(1174.8)	4547.3	(2062.6)
10"	(250)	10.125	(257.2)	9.449	(240.0)	4030.0	(1828.0)	7069.2	(3206.5)
12"	(300)	12.125	(308.0)	11.315	(287.4)	5780.0	(2621.8)	10138.0	(4598.5)

Dimensions taken from ASTM B 88-83.

- 1 cubic ft. of water weighs 62.41 Lbs.
- 1 cubic meter of water weighs 999.972 kg.
- 1 gallon (U.S.) weighs 8.335 Lbs.
- 1 liter weighs .999 kg.

STANDARD WEIGHT SCHEDULE 40 STEEL PIPE

Nominal Tubing Size	Outside Diameter		Inside Diameter		Nominal Weight Per 100 Ft. (30.5m)		Weight of Pipe Filled With Water Per 100 Ft. (30.5m)		
					Plain End				
					Lbs.	kg	Lbs.	kg	
In.	mm	In.	mm	In.	mm	Lbs.	kg	Lbs.	kg
3/8" (10)	.675	(17.1)	.493	(12.5)	57.0	(25.9)	65.3	(29.6)	
1/2" (15)	.840	(21.3)	.622	(15.8)	85.0	(38.6)	98.2	(44.5)	
3/4" (20)	1.050	(26.7)	.824	(20.9)	113.0	(51.3)	136.1	(61.7)	
1" (25)	1.315	(33.4)	1.049	(26.6)	168.0	(76.2)	205.5	(93.2)	
1 1/4" (32)	1.660	(42.2)	1.380	(35.1)	227.0	(103.0)	291.8	(132.4)	
1 1/2" (40)	1.900	(48.3)	1.610	(40.9)	272.0	(123.4)	360.2	(163.4)	
2" (50)	2.375	(60.3)	2.067	(52.5)	365.0	(165.6)	510.4	(231.5)	
2 1/2" (65)	2.875	(73.0)	2.469	(62.7)	579.0	(262.6)	786.5	(356.8)	
3" (80)	3.500	(88.9)	3.068	(77.9)	758.0	(343.8)	1078.4	(489.2)	
3 1/2" (90)	4.000	(101.9)	3.548	(90.1)	911.0	(413.2)	1339.5	(607.6)	
4" (100)	4.500	(114.3)	4.026	(102.3)	1079.0	(489.4)	1630.7	(739.7)	
5" (125)	5.563	(141.3)	5.047	(128.2)	1462.0	(663.2)	2329.1	(1056.4)	
6" (150)	6.625	(168.3)	6.065	(154.1)	1897.0	(860.5)	3149.1	(1428.4)	
8" (200)	8.625	(219.1)	7.981	(202.7)	2855.0	(1295.0)	5023.2	(2278.5)	
10" (250)	10.750	(273.1)	10.020	(254.5)	4048.0	(1836.1)	7465.6	(3386.3)	
12" (300)	12.750	(323.9)	12.000	(304.8)	4956.0	(2248.0)	9857.7	(4471.4)	
14" (350)	14.000	(355.6)	13.250	(336.6)	5457.0	(2475.3)	11433.1	(5185.9)	
16" (400)	16.000	(406.4)	15.250	(387.4)	6258.0	(2838.6)	14174.3	(6429.4)	
18" (450)	18.000	(457.2)	17.250	(438.2)	7059.0	(3201.9)	17187.9	(7796.3)	
20" (500)	20.000	(508.0)	19.250	(489.0)	7860.0	(3565.2)	20473.7	(9286.7)	
24" (600)	24.000	(609.6)	23.250	(590.6)	9462.0	(4291.9)	27862.5	(12638.2)	

Dimensions taken from ASTM A 53-82.

1 cubic ft. of water weighs 62.41 Lbs.
1 cubic meter of water weighs 999.972 kg.

1 gallon (U.S.) weighs 8.335 Lbs.
1 liter weighs .999 kg.

TRAPEZE HANGERS USING B-LINE STRUT OR ANGLE IRON

Length of Trapeze Bar	Nominal Pipe Sizes							
	2 1/2" (65mm) or less	3" (80mm)	3 1/2" (90mm)	4" (100mm)	5" (125mm)	6" (150mm)	8" (200mm)	10" (250mm)
1'-6" (0.46m)	1 1/2" x 1 1/2" x 3/16" B24SH	1 1/2" x 1 1/2" x 3/16" B24SH	1 1/2" x 1 1/2" x 3/16" B24SH	2" x 1 1/2" x 3/16" B22SH	2" x 1 1/2" x 3/16" B22SH	2 1/2" x 1 1/2" x 3/16" B12SH	3" x 2" x 3/16" B11SH	3" x 2" x 1/4" B11SH
2'-0" (0.61m)	1 1/2" x 1 1/2" x 3/16" B24SH	2" x 1 1/2" x 3/16" B22SH	2" x 1 1/2" x 3/16" B22SH	2" x 1 1/2" x 3/16" B22SH	2 1/2" x 1 1/2" x 3/16" B12SH	2 1/2" x 1 1/2" x 3/16" B12SH	3" x 2" x 3/16" B11SH	3" x 2" x 1/4" B11SH
2'-6" (0.76m)	2" x 1 1/2" x 3/16" B22SH	2" x 1 1/2" x 3/16" B22SH	2" x 1 1/2" x 3/16" B22SH	2 1/2" x 1 1/2" x 3/16" B12SH	2 1/2" x 1 1/2" x 3/16" B12SH	3" x 2" x 3/16" B11SH	3" x 2" x 1/4" B11SH	3" x 2" x 1/4" B11SH
3'-0" (0.91m)	2" x 1 1/2" x 3/16" B22SH	2" x 1 1/2" x 3/16" B22SH	2 1/2" x 1 1/2" x 3/16" B12SH	2 1/2" x 1 1/2" x 3/16" B12SH	3" x 2" x 3/16" B11SH	3" x 2" x 3/16" B11SH	3 1/2" x 2 1/2" x 1/4" B12SHA	3 1/2" x 2 1/2" x 5/16" B12SHA
4'-0" (1.22m)	2 1/2" x 1 1/2" x 3/16" B12SH	2 1/2" x 1 1/2" x 3/16" B12SH	2 1/2" x 1 1/2" x 3/16" B12SH	3" x 2" x 3/16" B11SH	3" x 2" x 3/16" B11SH	3" x 2" x 1/4" B11SH	3 1/2" x 2 1/2" x 5/16" B12SHA	4" x 3" x 5/16" B12SHA
5'-0" (1.52m)	2 1/2" x 1 1/2" x 3/16" B12SH	2 1/2" x 1 1/2" x 3/16" B12SH	3" x 2" x 3/16" B11SH	3" x 2" x 3/16" B11SH	3" x 2" x 1/4" B11SH	3 1/2" x 2 1/2" x 5/16" B12SHA	4" x 3" x 5/16" B12SHA	5" x 3 1/2" x 5/16" B11SHA
6'-0" (1.83m)	2 1/2" x 1 1/2" x 3/16" B12SH	3" x 2" x 3/16" B11SH	3" x 2" x 3/16" B11SH	3" x 2" x 1/4" B11SH	3 1/2" x 2 1/2" x 5/16" B12SHA	4" x 3" x 5/16" B12SHA	4" x 3" x 5/16" B12SHA	5" x 3 1/2" x 5/16" B11SHA
7'-0" (2.13m)	3" x 2" x 3/16" B11SH	3" x 2" x 3/16" B11SH	3" x 2" x 1/4" B11SH	3" x 2" x 1/4" B11SH	3 1/2" x 2 1/2" x 5/16" B12SHA	4" x 3" x 5/16" B12SHA	5" x 3 1/2" x 5/16" B11SHA	6" x 4" x 1/4" 2-B12SHA
8'-0" (2.44m)	3" x 2" x 3/16" B11SH	3" x 2" x 1/4" B11SH	3" x 2" x 1/4" B11SH	3 1/2" x 2 1/2" x 5/16" B12SHA	3 1/2" x 2 1/2" x 5/16" B12SHA	4" x 3" x 5/16" B12SHA	5" x 3 1/2" x 5/16" B11SHA	6" x 4" x 1/4" 2-B12SHA
9'-0" (2.74m)	3" x 2" x 3/16" B11SH	3" x 2" x 1/4" B11SH	3 1/2" x 2 1/2" x 5/16" B12SHA	3 1/2" x 2 1/2" x 5/16" B12SHA	3 1/2" x 2 1/2" x 5/16" B12SHA	4" x 3" x 5/16" B12SHA	5" x 3 1/2" x 5/16" B11SHA	6" x 4" x 3/8" 2-B11SHA
10'-0" (3.05m)	3" x 2" x 1/4" B11SH	3" x 2" x 1/4" B11SH	3 1/2" x 2 1/2" x 5/16" B12SHA	3 1/2" x 2 1/2" x 5/16" B12SHA	4" x 3" x 5/16" B12SHA	5" x 3 1/2" x 5/16" B11SHA	6" x 4" x 1/4" 2-B12SHA	6" x 4" x 3/8" 2-B11SHA

Reference: Table 3-14.1.6 standard for the installation of Sprinkler Systems, NFPA No. 13-1985, published by National Fire Protection Association.

Tolco™ to B-Line Cross Reference

Tolco to B-Line Cross

Tolco Fig#	B-Line Pt. #	Tolco Fig#	B-Line Pt. #	Tolco Fig#	B-Line Pt. #
2 STR 1/2"	B2400-1/2	BC-13-1/2	B307	BR-17-24	B297-24
2 STR 3/4"	B2400-3/4	BC-13-5/8	B309	BR-17-30	B297-30
2 STR 1"	B2400-1	BC-13-3/4	B321-5	BR-17-36	B297-36
2 STR 1 1/4"	B2400-1 1/4	BC-14-1/4	B303	BR-18-6	B293-6
2 STR 1 1/2"	B2400-1 1/2	BC-14-5/16	B304	BR-18-12	B293-12
2 STR 2"	B2400-2	BC-14-3/8	B321-1	BR-19-18	B293A-18
2 STR 2 1/2"	B2400-2 1/2	BC-14-1/2	B321-2	BR-18-24	B293-24
2 STR 3"	B2400-3	BC-14-5/8	B321-4	BR-19-6	B293A-6
2 STR 3 1/2"	B2400-3 1/2	BC-14-3/4	B321-5	BR-18-12	B293-12
2 STR 4"	B2400-4	BC-16	B314	BR-19-18	B293A-18
2 STR 5"	B2400-5	BC-17	B441-22	BR-19-24	B293A-24
2 STR 6"	B2400-6	BC-18-3/8	B212-3/8	BR-20	B439
2 STR 8"	B2400-8	BC-18-1/2	B212-1/2	BR-21	B356
65XT	N/C	BC-19	B427	BR-22-6	B409-6
69	Discontinued	BC-20	B355	BR-22-12	B409-12
69R	N/C	BC-21	B211	BR-22-18	B409-18
75	N/C	BC-23	B614	BR-22-24	B409-25
98	SC228	BC-70	B760-22 Series	C SAFETY END CAP	B852
98B	N/C	BC-71	B760-22A Series	C-14	B54
310	B2501	BC-72	B761-22 Series	C-14 END CAP	B204
310N 1/4	N2501-1/4	BC-73	B761-22A Series	CL-10	B217-20
310N 3/8	N2501-3/8	BR-10-8L	B185SHL	CR ISOLATOR	ISO
310N 1/2	N2501-1/2	BR-10-8R	B185SHR	CUSH CLP 1/4	BVT025
310N 5/8	N2501-5/8	BR-10-10L	B186SHL	CUSH CLP 3/8	BVT037
310N 3/4	N2501-3/4	BR-10-10R	B186SHR	CUSH CLP 1/2	BVT050
310N 7/8	N2501-7/8	BR-10-12L	B178SHL	CUSH CLP 5/8	BVT062
902	B335V	BR-10-12R	B178SHR	CUSH CLP 3/4	BVT075
912	B335-1	BR-10-18L	B181SHL	CUSH CLP 1	BVT100
913	B335-2	BR-10-18R	B181SHR	CUSH CLP 1 1/8	BVT112
914	B335	BR-10-20L	B182SHL	CUSH CLP 1 1/4	BVT125
915	B634	BR-10-20R	B182SHR	CUSH CLP 1 3/8	BVT137
915D	B635	BR-11-8 1/2	B187	CUSH CLP 1 1/2	BVT150
A SAFETY END CAP	B822	BR-11-10 1/2	B541	CUSH CLP 1 5/8	BVT162
A-12	B22	BR-11-12 1/2	B289-12	CUSH CLP 1 3/4	BVT175
A-12 End Cap	B205	BR-11-14 1/2	B289-14	CUSH CLP 2	BVT200
A-12 End Spot	B3322	BR-11-22	B292	CUSH CLP 2 1/8	BVT212
A-14	B24	BR-12	B290	CUSH CLP 2 1/2	BVT250
A-14 End Cap	B223	BR-13	B194	CUSH CLP 2 5/8	BVT262
BC-09	B312 Series	BR-14	B370	CUSH CLP 3	BVT300
BC-10	B751	BR-15-18	B196-18	CUSH CLP 3 1/8	BVT312
BC-11	B751-J Series	BR-15-24	B196-24	CUSH CLP 3 5/8	BVT362
BC-12	B751-J Series	BR-16-6	B198A-6	CUSH CLP 4	BVT400
BC-13-1/4	B303	BR-16-12	B198A-12	CUSH CLP 4 5/8	N/A
BC-13-5/16	B304	BR-17-12	B297-12	CUSH CLP 5 1/8	N/A
BC-13-3/8	B305	BR-17-18	B297-18	CUSH CLP 6 1/8	BVT612

Tolco™ to B-Line Cross Reference

Tolco Fig#	B-Line Pt. #	Tolco Fig#	B-Line Pt. #	Tolco Fig#	B-Line Pt. #
CUSH CLP IPS 1/4	BVP025	F-26	B138	L-36 L	B234L
CUSH CLP IPS 3/8	BVP037	F-27	B139	L-36 R	B234R
CUSH CLP IPS 1/2	BVP050	F-28	B132	L-37	B112
CUSH CLP IPS 3/4	BVP075	F-29	B339	L-38	B113
CUSH CLP IPS 1	BVP100	F-30	B337	L-39	B461
CUSH CLP IPS 1 1/4	BVP125	F-31	B136	L-40	B533
CUSH CLP IPS 1 1/2	BVP150	F-32	B532	L-41	B485
CUSH CLP IPS 2	BVP200	F-33	B142	L-42 L	B134L
CUSH CLP IPS 2 1/2	BVP250	F-34	B556	L-42 R	B134R
CUSH CLP IPS 3	BVP300	F-35	B135	L-43	B125
CUSH CLP IPS 3 1/2	BVP350	F-36	B140	L-44-12	B261-12
CUSH CLP IPS 4	BVP400	F-37	B143	L-44-16	B261-16
CUSH CLP IPS 5	BVP500	F-38	B334	L-44-18	B261-18
CUSH CLP IPS 6	BVP600	HEX HEAD BOLTS	HHCS	L-45-30	B162
CUSH STRIP	B1999	L-08	B231	L-45-45	B154
D-12	B12	L-10	B101	L-45-60	B150
D-12 END CAP	B221	L-11	B230	L-46-30	B246
E SAFETY END CAP	B822-A	L-12-3	B359	L-46-45	B248
E-12	B11	L-12-3 1/2	B360	L-46-60	B250
E-12 END CAP	B222	L-12-4	B361	L-47-30	N/C
EMTC-1/2	B2001	L-15	B372	L-47-45	B155
EMTC-3/4	B2002	L-16	B496-1	L-47-60	B159
EMTC-1	B2003	L-17	B496	L-48-30	N/C
EMTC-1 1/4	B2004	L-18	B102	L-48-45	B368
EMTC-1 1/2	B2005	L-19	B232	L-48-60	B366
EMTC-2	B2006	L-20	B103	NUT 1/4	N224WO
F-09	B129	L-21	B371-2	NUT 3/8	N228WO
F-10	B200D	L-22	B104	NUT 1/2	N225WO
F-11	B201D	L-23 U	B844	NUT 5/8	N255WO
F-12-1/2	B202-D	L-24 L	B503L	NUT 3/4	N275WO
F-12-5/8	B202-1D	L-24 R	B503R	NUT 7/8	N278WO
F-12-3/4	B202-2D	L-25 L	B503L	OD 1/4	B2023
F-13	B200	L-25	B503R	OD 3/8	B2024
F-14	B201	L-26 L	B236L	OD 1/2	B2025
F-15	B202	L-26 R	B236R	OD 5/8	B2026
F-15	B202	L-27	B357	OD 3/4	B2027
F-16	B202-1	L-28	B237	OD 7/8	B2008
F-17	B202-2	L-29	B240-378	OD 1	B2029
F-18	N/C	L-30	B558	OD 1 1/8	B2030
F-20	B141	L-31 L	B235L	OD 1 1/4	B2031
F-21	B342	L-31 R	B235R	OD 1 3/8	B2032
F-22	B340	L-32	B126	OD 1 1/2	B2004
F-23	B341	L-33	B127	OD 1 5/8	B2011
F-24	B504	L-34	B118	OD 1 3/4	B2005
F-25	B133	L-35	B239	OD 1 7/8	B2036

Tolco to B-Line Cross

Tolco™ to B-Line Cross Reference

Tolco to B-Line Cross

Tolco Fig#	B-Line Pt. #	Tolco Fig#	B-Line Pt. #	Tolco Fig#	B-Line Pt. #
OD 2	B2037	OD 8 ^{5/8}	B2022	RIGID 3/4	B2009
OD 2 ^{1/8}	B2038	OD 8 ^{3/4}	B2133	RIGID 1	B2010
OD 2 ^{1/4}	B2039	OD 8 ^{7/8}	B2134	RIGID 1 ^{1/4}	B2011
OD 2 ^{3/8}	B2013	OD 9	B2135	RIGID 1 ^{1/2}	B2012
OD 2 ^{1/2}	B2041	OD 9 ^{1/2}	B2139	RIGID 2	B2013
OD 2 ^{5/8}	B2042	OD 9 ^{5/8}	B2140	RIGID 2 ^{1/2}	B2014
OD 2 ^{3/4}	B2043	OD 10	B2143	RIGID 3	B2015
OD 2 ^{7/8}	B2014	OD 10 ^{3/4}	B2130	RIGID 3 ^{1/2}	B2016
OD 3	B2045	OD 11	B2151	RIGID 4	B2017
OD 3 ^{1/8}	B2046	OD 11 ^{5/8}	B2156	RIGID 5	B2019
OD 3 ^{1/4}	B2047	OD 12	B2159	RIGID 6	B2120
OD 3 ^{3/8}	B2048	OD 12 ^{3/4}	B2132	RIGID 8	B2122
OD 3 ^{1/2}	B2015	OD CP 3/8	B2024DCU	ROL-10	B377
OD 3 ^{5/8}	B2050	OD CP 1/2	B2025DCU	ROL-11	B376
OD 3 ^{3/4}	B2051	OD CP 5/8	B2026DCU	ROL-12*	B218
OD 3 ^{7/8}	B2052	OD CP 3/4	B2027DCU	ROL-13	B219 Series
OD 4	B2016	OD CP 7/8	B2008DCU	ROL-14	B379
OD 5 ^{1/8}	B2062	OD CP 1 ^{1/8}	B2030DCU	ROL-15	B479
OD 5 ^{1/4}	B2063	OD CP 1 ^{3/8}	B2032DCU	ROL-16	B3126 Series
OD 5 ^{3/8}	B2064	OD CP 1 ^{5/8}	B2011DCU	SPRA 1/4	N224
OD 5 ^{1/2}	B2019	OD CP 2 ^{1/8}	B2038DCU	SPRA 3/8	N228
OD 5 ^{5/8}	B2066	OD CP 2 ^{5/8}	B2042DCU	SPRA 1/2	N225
OD 5 ^{3/4}	B2067	OD CP 3 ^{1/8}	B2046DCU	SPRA 5/8	N255
OD 5 ^{7/8}	B2068	OD CP 3 ^{5/8}	B2050DCU	SPRA 3/4	N275
OD 6	B2069	OD CP 4 ^{1/8}	B2054DCU	SPRA 7/8	N278
OD 6 ^{1/8}	B2110	OD CP 5 ^{1/8}	B2062DCU	SPRC 1/4	N524
OD 6 ^{1/4}	B2111	OD CP 6 ^{1/8}	B2110DCU	SPRC 3/8	N528
OD 6 ^{3/8}	B2112	P-09	B280FL	SPRC 1/2	N525
OD 6 ^{1/2}	B2113	P-10	B279	SPRC 5/8	N555
OD 6 ^{5/8}	B2020	P-10 F	B279FL	SPRC 3/4	N575
OD 6 ^{3/4}	B2115	P-10 SQ	B279SQ	SPRD 1/4	N724
OD 6 ^{7/8}	B2116	P-11	B280	SPRD 3/8	N728
OD 7	B2117	P-11 F	B280FL	SPRD 1/2	N725
OD 7 ^{1/8}	B2118	P-11 SQ	B280SQ	SPRD 5/8	N755
OD 7 ^{1/4}	B2119	P-12	B281A	SPRD 3/4	N775
OD 7 ^{3/8}	B2120	P-12 F	B281AFL	SPRM 1/4	SN224
OD 7 ^{1/2}	B2121	P-12 SQ	B281ASQ	SPRM 3/8	SN228
OD 7 ^{5/8}	B2021	P-13	B281	SPRM 1/2	SN225
OD 7 ^{3/4}	B2123	P-13 F	B281FL	SPRM 5/8	SN255
OD 7 ^{7/8}	B2124	P-13 SQ	B281SQ	SWF 3/8	B446A-3/8
OD 8	B2125	P-14	B585	SWF 1/2	B446A-1/2
OD 8 ^{1/8}	B2126	P-15	B278	SWF 5/8	B446A-5/8
OD 8 ^{1/4}	B2127	PIPE PIER	DURA-BLOKS	SWF 3/4	B446A-3/4
OD 8 ^{3/8}	B2128	RIGID 3/8	B2001	SWFF 3/8	B446C-3/8
OD 8 ^{1/2}	B2129	RIGID 1/2	B2008	SWFF 1/2	B446C-1/2

Tolco™ to B-Line Cross Reference

Tolco Fig#	B-Line Pt. #	Tolco Fig#	B-Line Pt. #	Tolco Fig#	B-Line Pt. #
SWFF 5/8	B446C-5/8	W-18	B273		
SWFF 3/4	B446C-3/4	W-19	B122		
SWM 3/8	B446B-3/8	W-20	B124		
SWM 1/2	B446B-1/2	W-21	B123		
SWM 5/8	B446B-5/8	W-22 L	B274L		
		W-22 R	B274R		
SWM 3/4	B446B-3/4	W-23	B276		
SWMF 3/8	B446-3/8	W-24	B495		
SWMF 1/2	B446-1/2	W-25	B362		
SWMF 5/8	B446-5/8	Z-10	B105		
SWMF 3/4	B446-3/4				
TSN 1/4	TN224	Z-15	B108		
TSN 3/8	TN228	Z-17	B586		
TSN 1/2	TN225	Z-25	B515		
U-10	B107				
U-11	B116-52				
U-12	B116-12				
U-13-7 1/4	B333-1				
U-13-8 1/2	B333-2				
U-13-10 3/8	B333-3				
U-16	B107-22A				
U-18	B398-1				
U-22	B169, B170				
U-24	B167, B172				
U-26	B173				
U-29	B400-1				
U-30	B400-3				
U-31	B425				
U-32	B519				
U-33	B581				
U-34	N/C				
UNIV-1/2	B2208				
UNIV-3/4	B2209				
UNIV-1	B2210				
UNIV-1 1/4	B2211				
UNIV-1 1/2	B2212				
UNIV-2	B2213				
W-10 L	B267L				
W-10 R	B267R				
W-11 L	B269L				
W-11 R	B269R				
W-12	B119				
W-13	B120				
W-14	B121				
W-16	B271				
W-17	B272				

Index

Part No.	Page #	Part No.	Page #	Part No.	Page #	Part No.	Page #
4B Series	188	4D2024	37-39	4D441-22A	44	981	124
4D21	26-29	4D2024PA	37-39	4D5000-1/2	40	985	125
4D21S	26-29	4D2025	37-39	4D5000-3/8	40	986	125
4D21SH	26-29	4D2025PA	37-39	4D5001-3/8	41	7187	267
4D22	22-25	4D2026	37-39	4D5100-1/2	42	7195	267
4D22S	22-25	4D2026PA	37-39	4D5100-3/8	42	7197	267
4D22SH	22-25	4D2027	37-39	4D821	45	7887-2	266
4D2000	37-39	4D2027PA	37-39	4D822	45	960674A	77
4D2000PA	37-39	4D2030	37-39	4DB Discontinued	30	ACB Series	262
4D2001	37-39	4D2030PA	37-39	4DB Discontinued	30	ACPD Series	265
4D2001PA	37-39	4D2031	37-39	4DB Discontinued	30	ACPW-xx-2 Series	264
4D2002	37-39	4D2031PA	37-39	4DB Discontinued	30	ACS-xx-xxxF Series	263
4D2002PA	37-39	4D2037	37-39	4DB Discontinued	30	ACS-xx-xxxH Series	263
4D2003	37-39	4D2037PA	37-39	4DB Discontinued	30	ADH Series	269
4D2003PA	37-39	4D2038	37-39	4DDN228	31	AHHK-1/4	275
4D2004	37-39	4D2038PA	37-39	4DNW223	34	AHHK-3/8	275
4D2004PA	37-39	4D2039	37-39	4DNW224	34	APC Series	269
4D2005	37-39	4D2039PA	37-39	4DNW228	34	ARC Series	267
4D2005PA	37-39	4D2041	37-39	4DSN223	33	ARS Series	266
4D2006	37-39	4D2041PA	37-39	4DSN224	33	ARW Series	267
4D2006PA	37-39	4D2042	37-39	4DSN228	33	ASA Series	268
4D2008	37-39	4D2042PA	37-39	4DTN223	33	ATM-37	268
4D2008PA	37-39	4D2043	37-39	4DTN224	33	ATR	92
4D2009	37-39	4D2043PA	37-39	4DTN228	33	AWA Series	261
4D2009PA	37-39	4D2045	37-39	4DV Discontinued	34	AWS-CH	269
4D2010	37-39	4D2045PA	37-39	4DV Discontinued	34	AWS-OH	269
4D2010PA	37-39	4D2046	37-39	4DV Discontinued	34	AWS-PH	269
4D2011	37-39	4D2046PA	37-39	4DV Discontinued	34	B11	50-51
4D2011PA	37-39	4D2047	37-39	65	119, 157	B11A	50-51
4D2012	37-39	4D2047PA	37-39	65XT-3/8	119, 157	B11AL	219
4D2012PA	37-39	4D2048	37-39	66	119, 157	B11B	51
4D2013	37-39	4D2048PA	37-39	67SS	157	B11H1 ⁷ / ₈	74
4D2013PA	37-39	4D2050	37-39	68SS	157	B11KO6	75
4D2014	37-39	4D2050PA	37-39	69	119, 156	B11S	74
4D2014PA	37-39	4D2051	37-39	69R	119, 156	B11S58	76
4D2015	37-39	4D2051PA	37-39	75	89, 119	B11SH	74
4D2015PA	37-39	4D2052	37-39	98	91, 119	B12	52-53
4D2016	37-39	4D2052PA	37-39	98B	91, 119	B12A	52-53
4D2016PA	37-39	4D280	43	825	120	B12AL	219
4D2017	37-39	4D280FL	43	825A	121	B12B	52
4D2017PA	37-39	4D280SQ	43	828	122	B12H1 ⁷ / ₈	74
4D2023	37-39	4D441-21	44	980	123	B12H1 ⁷ / ₈ AL	220
4D2023PA	37-39	4D441-22	44	980H	123	B12KO6	75

Part No.	Page #	Part No.	Page #	Part No.	Page #	Part No.	Page #
B12KO6AL	220	B24	58-59	B42SH	74	B54SHSS4	222
B12S	74	B24A	58-59	B42SHSS4	222	B54SHSS6	222
B12S58	76	B24B	58	B42SS4	222	B54SS4	222
B12SH	74	B24C	58	B44M	76	B54SS6	222
B12SHAL	220	B24H17/8	74	B52	66-67	B62	243
B22	54-57	B24H17/8SS4	222	B52A	66-67	B62A	243
B22A	54, 56-57	B24H17/8SS6	222	B52B3	66	B72	244
B22A3	55	B24H25	76	B52B4	66	B72A	244
B22A4	55	B24KO6	75	B52H17/8	74	B101	110
B22AAL	219	B24M	76	B52H17/8SS4	222	B102	111
B22AD3	55	B24S	74	B52H17/8SS6	222	B103	111
B22AL	219	B24S58	76	B52H25	76	B104	111
B22B	55	B24SH	74	B52-I Series	258	B104SH	115
B22B3	55	B24SHSS4	222	B52-IFS	260	B105	132
B22C	55	B24SHSS6	222	B52KO6	75	B106-12	132
B22C3	55	B24SS4	222	B52M	76	B106-32	132
B22D	55	B24SS6	222	B52S	74	B106-42	132
B22D3	55	B32	62-63	B52S58	76	B106-52	132
B22E	55	B32A	62-63	B52SH	74	B107	128
B22E3	55	B32B	62	B52SHA	75	B107-22A	128
B22H17/8	74	B32C	62	B52SHSS4	222	B107S	129, 167
B22H17/8AL	220	B32H17/8	74	B52SHSS6	222	B108	132
B22H17/8SS4	222	B32H17/8SS4	222	B52SS4	222	B109S	115
B22H17/8SS6	222	B32H25	76	B52SS6	222	B110	132
B22H25	76	B32-I Series	257	B54	68-69	B111	133
B22-I Series	256	B32-IFS	260	B54A	68-69	B112	115
B22-IFS	260	B32KO6	75	B54AAL	219	B113	115
B22KO6	75	B32M	76	B54AL	219	B115	111
B22KO6AL	220	B32S	74	B54B3	68	B116-12	128
B22LPL	55	B32S58	76	B54B4	68	B116-32	128
B22M	76	B32SH	74	B54H17/8	74	B116-32A	128
B22PL	55	B32SHSS4	222	B54H17/8AL	220	B116-42	128
B22S	74	B32SS4	222	B54H17/8SS4	222	B116-52	128
B22S58	76	B42	64-65	B54H17/8SS6	222	B118	113
B22SH	74	B42A	64-65	B54H25	76	B119	135
B22SHA	75	B42B	64	B54KO6	75	B120	135
B22SHAL	220	B42H17/8	74	B54KO6AL	220	B121	135
B22SHSS4	222	B42H17/8SS4	222	B54M	76	B122	135
B22SHSS6	222	B42H25	76	B54S	74	B123	136
B22SS4	222	B42KO6	75	B54S58	76	B124	136
B22SS6	222	B42M	76	B54SH	74	B125	113
B22TH	72-73, 75	B42S	74	B54SHA	75	B126	114
B22X	55-57	B42S58	76	B54SHAL	220	B127	114

Index

Part No.	Page #	Part No.	Page #	Part No.	Page #	Part No.	Page #
B129	107	B173	130	B200D	107	B237	112
B132	108	B174SHL	143	B201	107	B238L	112
B133	108	B174SHR	143	B201D	107	B238R	112
B134L	113	B175SHL	143	B202	107	B239	112
B134R	113	B175SHR	143	B202-1	107	B241S	209
B135	108	B176SHL	143	B202-1D	107	B243	116
B136	109	B176SHR	143	B202-2	107	B244	116
B137	109	B177SHL	143	B202-2D	107	B245	116
B138	108	B177SHR	143	B202D	107	B246	116
B139	108	B178SHL	143	B203	152, 211	B247	116
B140	108	B178SHR	143	B204	152, 211	B248	116
B141	107	B179SHL	143	B205	152, 211, 260	B249	116
B142	108	B179SHR	143	B206	152, 211, 260	B250	116
B143	108	B180SHL	143	B210	158	B251	116
B147	116	B180SHR	143	B210A	158	B252	116
B148	116	B181SHL	143	B211	164	B253	116
B149	116	B181SHR	143	B212- ¹ / ₄	164	B261 Series	126
B150	116	B182SHL	143	B212- ³ / ₈	164	B266	129
B151	116	B182SHR	143	B213	164	B267L	134
B152	116	B183SHL	143	B214L	148	B267R	134
B154	116	B183SHR	143	B214R	148	B268L	134
B155	117	B184SHL	143	B215S	209	B268R	134
B156	117	B184SHR	143	B216S	209	B269L	135
B157	117	B185SHL	143	B217-20	77, 211	B269R	135
B158	117	B185SHR	143	B217-24	77, 211	B270L	134
B159	117	B186SHL	143	B217AL	219	B270R	134
B160	117	B186SHR	143	B217FFAL	219	B271	135
B161	117	B187	139	B217P	77, 211, 219, 241	B272	135
B162	116	B188	139	B218	191	B273	135
B163	116	B189	139	B219 Series	192-193	B274L	136
B164	116	B190	140	B220	152, 220, 260	B274R	136
B165	116	B191-18	140	B221	152, 220	B276	136
B166 Series	215	B191-24	140	B222	152, 220	B277	136
B166-46 Series	215	B192	140	B223	152, 220	B278	139
B166CL	215	B194	144	B230	110	B279	137
B167	127	B195	144	B231	110	B279FL	137
B168	127	B196-18	143	B232	111	B279SQ	137
B169	127	B196-24	143	B234L	113	B280	137
B170	127	B198-6	143	B234R	113	B280FL	137
B171	127	B198-12	143	B235L	112	B280SQ	137
B172	127	B198A-6	143	B235R	112	B281	138
B172-12	127	B198A-12	143	B236L	112	B281A	138
B172-22A	127	B200	107	B236R	112	B281AFL	138

Part No.	Page #	Part No.	Page #	Part No.	Page #	Part No.	Page #
B281ASQ	138	B331	116	B380 Series	260	B428	134
B281FL	138	B332	116	B381	149	B432	109
B281M	138	B333-1	130	B382	149	B435	164
B281MSQ	138	B333-2	130	B383	149	B436	210
B281SQ	138	B333-3	130	B384	149	B436S	210
B283	152, 211	B334	109	B385	149	B437 Series	183
B284	152, 211	B335	117	B386 Series	see Fig. 4B	B438	149
B285	152, 211	B335-1	117	B387 Series	133	B439	149
B286	152, 211	B335-2 Series	117	B390BX	210	B440	144
B287	152	B335V Series	117	B390S	210	B441-22 Series	163
B288	152	B337	109	B392-11 Series	212	B441-22A Series	163
B289-12	140	B339	109	B392-12 Series	212	B441Z-22	163
B289-14	141	B340	107	B392-22 Series	212	B441Z-22A	163
B290	140	B341	107	B392-32 Series	212	B444 Series	158
B291	141	B342	107	B393-1	215	B446 Series	88, 216
B292	141	B346L	137	B394 Series	188	B446A Series	88, 216
B293 Series	144	B346R	137	B398-1	131	B446B Series	88, 216
B293A Series	144	B349	150	B400	131	B446C Series	88, 216
B297 Series	142	B350	150	B400-1	131	B447	212
B300	139	B351L Series	155	B400-2	131	B447A	212
B303	159	B355	164	B400-3	131	B449-4	145
B304	159	B356	190	B400-4	131	B449-8	145
B305	159	B357	112	B405	130, 165	B449-12	145
B306	159	B358 Series	130	B405A	165	B449-18	145
B307	159	B359	110	B407 Series	133	B450 Series	127
B308	159	B360	110	B408 Series	130	B451-1	130
B309	159	B361	111	B408SLBVNS	153	B451-2	130
B312 Series	159	B362	136	B409 Series	143	B451-3	130
B314	163	B363	117	B409DB Series	145	B460 Series	210
B321-1	159	B364	117	B410-11	133	B461	115
B321-2	159	B365	117	B410-12	133	B464 Series	210
B321-3	159	B366	117	B410-22	133	B465	210
B321-4	159	B367	117	B410-32	133	B472	148
B321-5	159	B368	117	B410-52	133	B473	148
B322	116	B369	117	B411 Series	149	B474	148
B323	116	B370	144	B412	129	B475	148
B324	116	B371	114	B420-378	110	B477	151
B325	116	B371-2	115	B420-578	110	B477H	151
B326	116	B372	114	B420-778	110	B477HP	151
B327	116	B374	111	B420-978	110	B477P	151
B328	116	B376	151	B422 Series	167, 184	B478	151
B329	116	B377	151	B425	129	B478H	151
B330	116	B379	194	B427	165	B478HP	151

Index

Part No.	Page #	Part No.	Page #	Part No.	Page #	Part No.	Page #
B478P	151	B588	128	B751-J Series	160	B1532S	176
B479	195	B589	215	B752	160	B1534S	176
B485	114	B589-62	249	B753 Series	160	B1540S	176
B488	116	B590	215	B755	161	B1548S	176
B494 Series	142	B591 Series	189	B755- ³ / ₈ -J Series	161	B1556S	176
B495	136	B593	167	B756- ³ / ₈	161	B1564S	176
B496	115	B594	129	B760-22 Series	166	B1999	181
B496-1	115	B595	130	B760-22A Series	166	B2000	172
B500 Series	86, 162	B596	129	B761-22 Series	166	B2001	172
B501 Series	86	B598-62	252	B761-22A Series	166	B2001AL	220
B503L	114	B600-62	246	B766 Series	214	B2001SS4	223
B503R	114	B601-62	250	B767 Series	214	B2002	172
B504	108	B602-A	165	B768 Series	214	B2003	172
B514L	148	B602-B	165	B769 Series	214	B2004	172, 174
B514R	148	B602-C	165	B802D Series	146	B2005	172, 174
B515	134	B613	150, 167	B809B Series	147	B2006	172
B516	211	B613A	150, 167	B810 Series	146	B2008	172, 174
B516S	211	B614	150, 167	B811 Series	147	B2008AL	220
B518 Series	213	B616 Series	208	B812 Series	147	B2008DCU	173
B519	129	B616-22A Series	208	B816	146	B2008SS4	223
B521	115	B616S Series	208	B822	152	B2009	172, 174
B522	116	B616S-22A Series	209	B822A	152	B2009AL	220
B526	132	B616TG- ⁹ / ₁₆	209	B823-22	153	B2009SS4	223
B527	128	B617	89, 215	B823-22A	153	B2010	172, 174
B528	107	B619	215	B823-42	153	B2010AL	220
B529	111	B631 Series	126	B823-52	153	B2010DCU	173
B532	109	B632 Series	126	B825-22	153	B2010SS4	223
B533	114	B633 Series	118	B825-52	153	B2011	172, 174
B541	139	B634	118	B844	113	B2011AL	220
B556	109	B635	118	B844W	113	B2011DCU	173
B557	107	B650 Series	118	B852	152	B2011SS4	223
B558	111	B655 Series	92	B852S Series	146	B2012	172, 174
B560	150	B656 Series	92	B888W	113	B2012AL	220
B562	150	B663	114	B999	77	B2012SS4	223
B570	138	B670 Series	184	B1508	176	B2013	172, 174
B570A	139	B671 Series	184	B1508S	176	B2013AL	220
B571	136	B700 Series	162	B1512	176	B2013SS4	223
B578	129	B701 Series	160	B1512S	176	B2014	172, 174
B580	133	B705 Series	161	B1516	176	B2014AL	220
B581	129	B718 Series	213	B1516S	176	B2014SS4	223
B585	139	B719AL	213	B1520	176	B2015	172, 174
B586	132	B750 Series	162	B1520S	176	B2015AL	220
B587 Series	149	B751	160	B1524S	176	B2015SS4	223

Part No.	Page #	Part No.	Page #	Part No.	Page #	Part No.	Page #
B2016	172, 174	B2050DCU	173	B2116	175	B2503	259
B2016AL	220	B2051	174	B2117	175	B2505	259
B2016SS4	223	B2052	174	B2118	175	B2506	259
B2017	172, 174	B2054	174	B2119	175	B2508	259
B2017AL	220	B2054DCU	173	B2120	175	B2601	177
B2017SS4	223	B2055	174	B2121	175	B2602	177
B2018	172, 175	B2056	174	B2123	175	B2603	177
B2018AL	220	B2058	174	B2124	175	B2608	177
B2018SS4	223	B2059	175	B2125	175	B2609	177
B2019	172, 175	B2060	175	B2126	175	B2610	177
B2019AL	220	B2062	175	B2126DCU	173	B3033 Series	156
B2019SS4	223	B2062DCU	173	B2127	175	B3034 Series	156
B2020	172, 175	B2063	175	B2128	175	B3036L Series	155
B2020AL	220	B2064	175	B2129	175	B3037Z	158
B2020SS4	223	B2066	175	B2130	172, 175	B3322	152, 260
B2021	172, 175	B2067	175	B2132	172, 175	B3332	152, 260
B2022	172, 175	B2068	175	B2207	169	B3342	152, 260
B2023	174	B2069	175	B2208	169	B3352	152, 260
B2024	174	B2070	183	B2209	169	B3362 Series	155
B2024DCU	173	B2071	183	B2210	169	B3363 Series	155
B2025	174	B2072	183	B2211	169	B3364 Series	155
B2025DCU	173	B2073	183	B2212	169	B3365 Series	155
B2026	174	B2074	183	B2213	169	B3367 Series	see Fig. 69
B2026DCU	173	B2075	183	B2301 Series	185	B3367S-1 Series	184
B2027	174	B2076	183	B2302 Series	185	B3367S-2 Series	184
B2027DCU	173	B2077	183	B2308	253	B3373 Series	186
B2030	174	B2078	183	B2309	253	B3690 Series	187
B2030DCU	173	B2079	183	B2310	253	B3690F Series	187
B2031	174	B2080	183	B2311	253	B4050	216
B2037	174	B2084	185	B2312	253	B4051	216
B2038	174	B2085	185	B2313	253	B4060	217
B2038DCU	173	B2086	185	B2314	253	B4061	217
B2039	174	B2087	185	B2315	253	B4062	217
B2041	174	B2088	185	B2350	253	B4063	217
B2042	174	B2089	185	B2351	253	B4064	217
B2042DCU	173	B2090	185	B2352	253	B4065	217
B2043	174	B2091	185	B2353	253	B4066	217
B2045	174	B2110	175	B2354	253	B4067	217
B2046	174	B2110DCU	173	B2355	253	B4068	217
B2046DCU	173	B2111	175	B2400 Series	182	B4069	217
B2047	174	B2112	175	B2417 Series	183	B4070	217
B2048	174	B2113	175	B2500	259	B4071	217
B2050	174	B2115	175	B2501 Series	259	B4072	217

Index

Part No.	Page #	Part No.	Page #	Part No.	Page #	Part No.	Page #
B4073	217	B6138	246	B6504	246	BFV42H1 ^{7/8}	228
B4074	217	B6139	246	B6526	252	BFV42SH	228
B4075	217	B6140	246	B6532	247	BFV100	233
B4076	217	B6141	246	B6533	249	BFV101	240
B4077	217	B6142	247	B6557	246	BFV103	240
B4078	217	B6143	246	B6558	248	BFV104	240
B4079	217	B6144L	248	B6594	251	BFV118	240
B4080	217	B6144R	248	B7105	252	BFV129	237
B4081	217	B6147	250	B7116	251	BFV132	238
B4082	217	B6148	250	B7205	253	BFV133	238
B4083	217	B6149	250	BC442	158	BFV135	239
B4084	217	B6150	250	BCTB1 Series	170	BFV136	239
B4085	217	B6151	250	BCTB2 Series	171	BFV140	238
B4086	217	B6152	250	BCTB3 Series	171	BFV141	237
B4087	217	B6154	250	BCTS1 Series	170-171	BFV142	239
B4088	217	B6155	250	BCTS2 Series	170-171	BFV143	238
B4089	217	B6156	250	BCTS3 Series	170-171	BFV200	233
B4090	217	B6157	250	BD40	260	BFV201	237
B4091	217	B6158	250	BE-5-8	260	BFV202	237
B4092	217	B6159	250	BE-9-12	260	BFV-223	230
B4093	217	B6160	250	BFP22	226-227	BFV-223WO	230
B4094	216	B6161	250	BFP22A	226-227	BFV-224	230
B4095	216	B6162	250	BFP22H1 ^{7/8}	226	BFV-224WO	230
B6101	247	B6163	250	BFP22SH	226	BFV-225	230
B6102	248	B6164	250	BFP42	228-229	BFV-225WO	230
B6103	248	B6165	250	BFP42A	228-229	BFV-228	230
B6104	248	B6167	251	BFP42H1 ^{7/8}	228	BFV-228WO	230
B6105	252	B6172	251	BFP42SH	228	BFV280SQ	241
B6107	251	B6173	252	BFP409 Series	236	BFV281SQ	241
B6107-62A	251	B6202	245	BFP494 Series	236	BFV300	233
B6108	252	B6205	253	BFP2400-2	234	BFV334	239
B6110	252	B6211	253	BFP2400-3	234	BFV337	239
B6112	249	B6230	247	BFP2400-4	234	BFV340	237
B6118	249	B6232	248	BFP2400-6	234	BFV341	238
B6126	249	B6234L	249	BFP3104-8	235	BFV342	238
B6127	249	B6234R	249	BFP3104-10	235	BFV371-2G	240
B6129	245	B6239	248	BFP3104-12	235	BFV409 Series	236
B6132	247	B6337	247	BFV22	226-227	BFV494 Series	236
B6133	247	B6340	245	BFV22A	226-227	BFV501 Series	230
B6134L	249	B6341	246	BFV22H1 ^{7/8}	226	BFV532	239
B6134R	249	B6357	248	BFV22SH	226	BFV557	337
B6135	247	B6374	248	BFV42	228-229	BFV558	240
B6136	247	B6409 Series	253	BFV42A	228-229	BFV650	241

Part No.	Page #	Part No.	Page #	Part No.	Page #	Part No.	Page #
BFV655 Series	232	BKC100	93	BMM-5	245	BVS-12	181
BFV751-1/2	234	BKC200	93	BMM-5L	245	BVS-120	181
BFV751-3/8	234	BKCC	94	BMM-5S	245	BVT Series	178
BFV751-5/8	234	BKF100-4	95	BMM-6	245	CLDP10	199
BFV751J-1/2	234	BKF100-6	95	BMM-6L	245	CNPSS Series	87
BFV751J-3/8	234	BKH-094 Series	98	BMM-6S	245	DB_DS Series	200-201
BFV751J-5/8	234	BKH-094K Series	98	BMS-6	80	DB5	197
BFV755-1/2	235	BKL-063 Series	97	BMS-6L	81	DB10	197
BFV755-3/8	235	BKL-063K Series	97	BMS-6M	81	DB10-28	198
BFV2008	233	BKL-094 Series	97	BMS-6S	81	DB10-36	198
BFV2009	233	BKL-094K Series	97	BMS-8	80	DB10-42	198
BFV2010	233	BKP10063	94	BMS-8L	81	DB10-50	198
BFV2011	233	BKP10094	94	BMS-8M	81	DB10-60	198
BFV2012	233	BKP20125	94	BMS-8S	81	DB20	197
BFV2013	233	BKP20188	94	BMS-10	80	DB30	197
BFV2014	233	BKT-063 Series	100	BMS-10L	81	DB40	197
BFV2015	233	BKT-063K Series	100	BMS-10M	81	DB48	197
BFV2016	233	BKW063	93	BMS-10S	81	DB610	197
BFV2017	233	BKW094	93	BMS-12	80	DB620	197
BFV3104 -1 thru 6	235	BKW125	93	BMS-12M	81	DB630	197
BFV3104-8	235	BKW188	93	BMS-12S	81	DB640	197
BFV3104-10	235	BKYH18-094	98	BMS-D-12	80	DB648	197
BFV3104-12	235	BKYH18-094 Series	99	BMS-D-12L	81	DBE10-8	199
BFVATR Series	232	BKYH18-094K Series	99	BMS-D-12M	81	DBE10-12	199
BFVATRHN Series	232	BKYH30-094	98	BMT-6	82	DBE10-16	199
BFVFW Series	232	BKYH30-094 Series	99	BMT-8	82	DBM	197
BFVHHCS Series	231	BKYH30-094K Series	99	BMT-10	82	DBM-__ Series	198
BFVHN Series	231	BKYT12-063	100	BMT-12	82	DBM-__CT Series	198
BFVSL Series	232	BKYT12-063 Series	101	BMT-D-12	82	DBP	197
BHR1225ZN	92	BKYT12-063K Series	101	BP081SS	177	DBR10-12	199
BHR1238ZN	92	BKYT18-063	100	BP110SS	177	DBR2-31/2	202
BHR1250ZN	92	BKYT18-063 Series	101	BP135SS	177	DBR4-6	202
BHR1262ZN	92	BKYT18-063K Series	101	BP175SS	177	DBR8-10	202
BHSC100	47	BKYT30-063	100	BP205SS	177	DBR12-14	202
BHSC100B22	47	BKYT30-063 Series	101	BP250SS	177	DBR16-20	202
BHSC1004D21	47	BKYT30-063K Series	101	BP300SS	177	DCN 3/8	86
BHSC1004D22	47	BL1400 Series	186	BP325SS	177	FFW Series	90
BKA25-063 Series	104	BMM-3	245	BP375SS	177	FW Series	90
BKA25-063K Series	104	BMM-3L	245	BP425SS	177	HHCS Series	87
BKB25-063 Series	102	BMM-3S	245	BP475SS	177	HN Series	89
BKB25-06K3 Series	103	BMM-4	245	BPC Series	169	IPH Series	180
BKB38-094 Series	102	BMM-4L	245	BTS22TH	72-73	IPH18230	180
BKB38-094K Series	103	BMM-4S	245	BVP Series	179	ISO	181

Index

Part No.	Page #	Part No.	Page #	Part No.	Page #	Part No.	Page #
LW Series	90	N555	81	SA154	275	TN226	82
MSQN Series	89	N555WO	80	SA155	275	TN227	82
N221	81	N575	81	SA158	271-274	TN228	36, 82
N221WO	80	N575WO	80	SA276	271-274	TN255	82
N222	81	N621	245	SA318	271-274	TN525	82
N222WO	80	N621WO	245	SC228	91, 119		
N223	81	N622	245	SC-UB	91		
N223WO	80	N622WO	245	SFHMS Series	87		
N224	35, 81	N624	245	SHHMS Series	87		
N224SS6	221, 223	N624WO	245	SLN1/2	90		
N224WO	36, 80	N627	245	SLN5/8	90		
N224WOSS6	221, 223	N627WO	245	SLWN1/4	90		
N225	35, 81	N721	81	SLWN1/2	90		
N225SS6	221, 223	N722	81	SLWN3/8	90		
N225WO	36, 80	N723	81	SLWN5/8	90		
N225WOSS6	221, 223	N724	81	SLWNM6	90		
N226	81	N724SS6	211	SLWNM8	90		
N226WO	80	N725	81	SLWNM10	90		
N227	81	N725SS6	211	SLWNM12	90		
N227WO	80	N726	81	SN224 Series	83		
N228	35, 81	N727	81	SN224WO Series	82		
N228SS6	221, 223	N728	81	SN225 Series	83		
N228WO	36, 80	N728SS6	211	SN225WO Series	82		
N228WOSS6	221, 223	N755	81	SN228 Series	83		
N255	81	N775	81	SN228WO Series	82		
N255WO	80	N778	81	SN524 Series	83		
N275	81	N2500 Series	259	SN525 Series	83		
N275WO	80	N7221	245	SN525WO Series	82		
N278	81	N7222	245	SN528 Series	83		
N278WO	80	N7224	245	SN724 Series	83		
N521	81	N7227	245	SN725 Series	83		
N522	81	NW524	35, 83	SN728 Series	83		
N523	81	NW525	35, 83	SQN Series	89		
N524	81	NW528	35, 83	SRHMS Series	87		
N524SS6	211, 213	NWM6	83	STN224 Series	82		
N525	81	NWM8	83	STN225 Series	82		
N525SS6	211, 213	NWM10	83	STN228 Series	82		
N525WO	80	NWM12	83	STN525 Series	82		
N525WOSS6	211, 213	RSK010	226, 228	TN221	82		
N526	81	SA101	275	TN222	82		
N527	81	SA102	275	TN223	82		
N528	81	SA110	275	TN224	36, 82		
N528SS6	211, 213	SA131	275	TN225	36, 82		

Typical Strut Applications

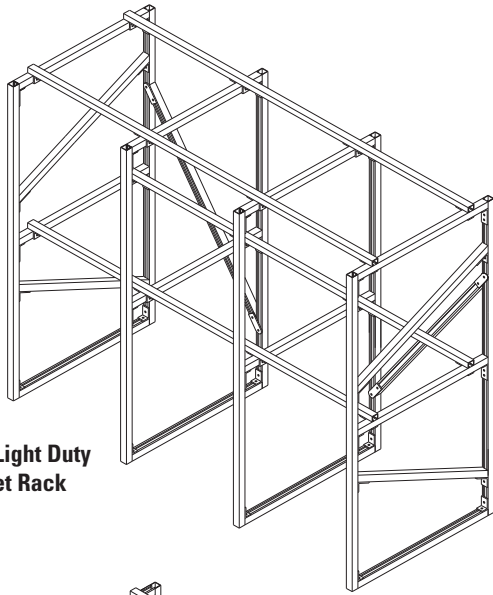

**3-Tier Light Duty
Pallet Rack**

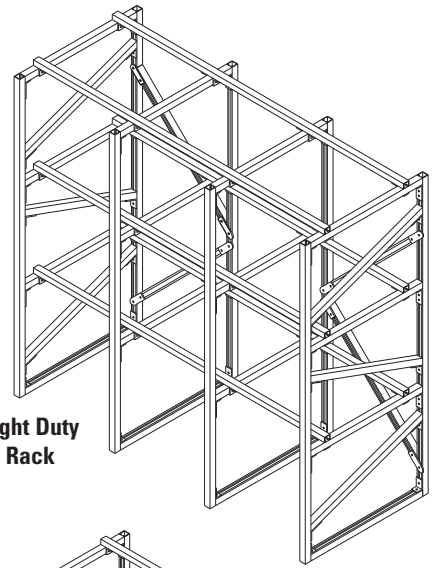

**4-Tier Light Duty
Pallet Rack**

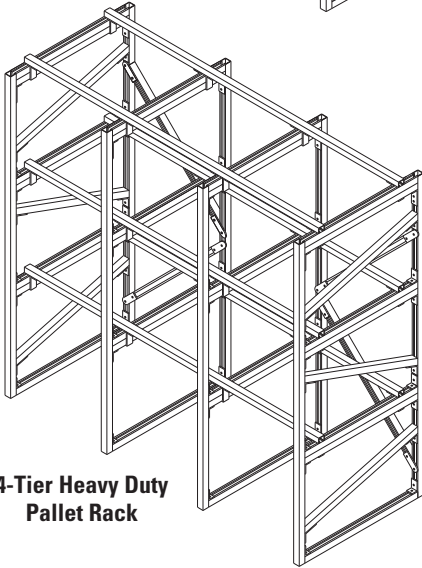

**4-Tier Heavy Duty
Pallet Rack**

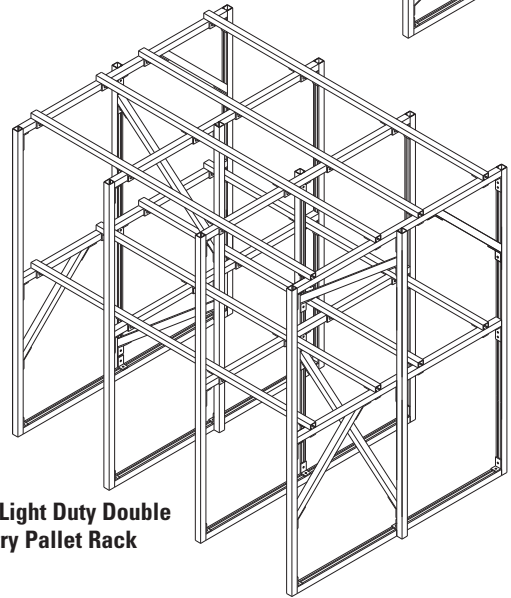

**3-Tier Light Duty Double
Entry Pallet Rack**

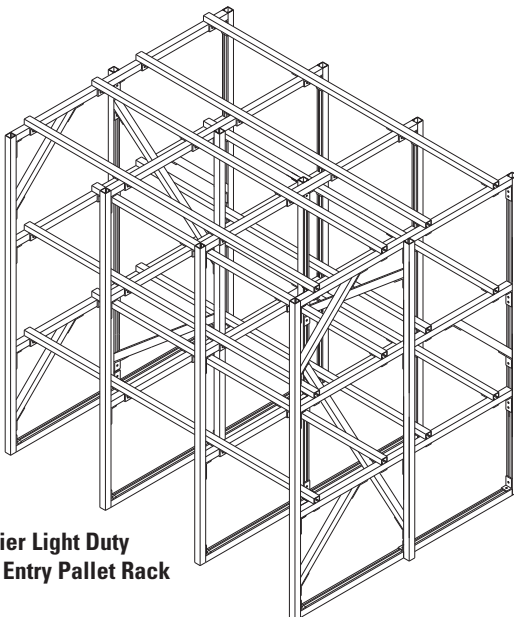

**4-Tier Light Duty
Double Entry Pallet Rack**

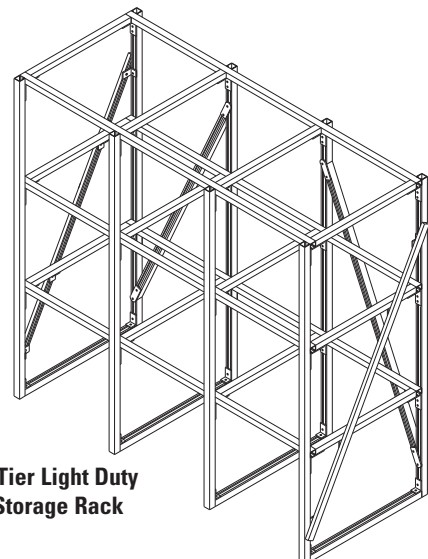

**3-Tier Light Duty
Storage Rack**

Typical Strut Applications

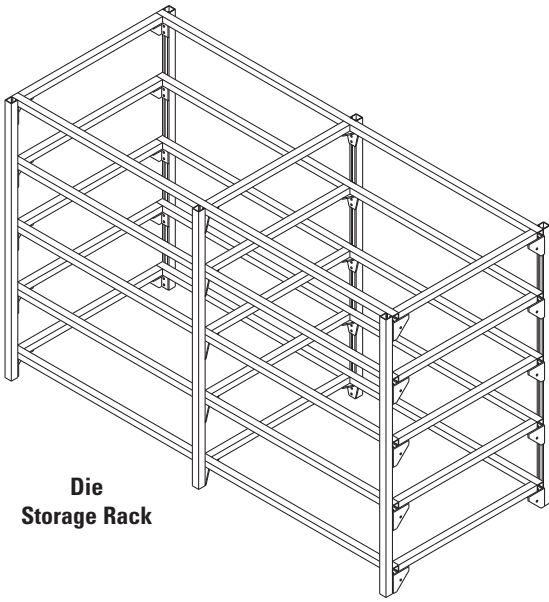

**Die
Storage Rack**

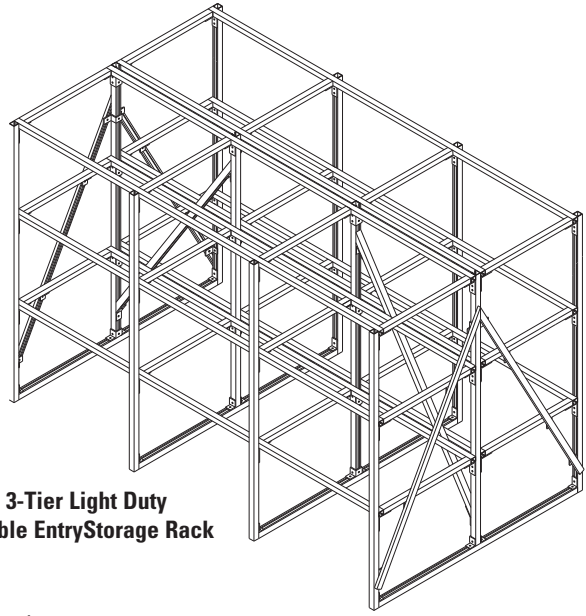

**3-Tier Light Duty
Double Entry Storage Rack**

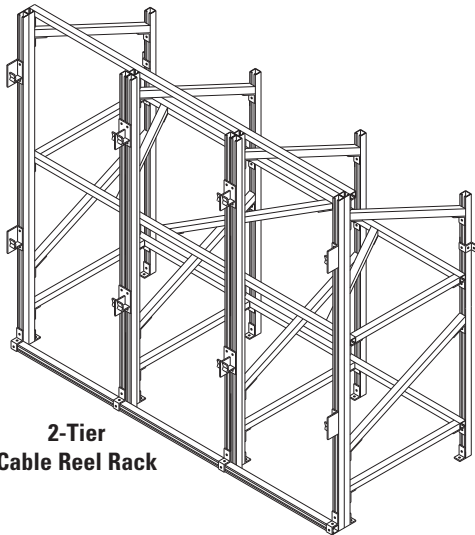

**2-Tier
Cable Reel Rack**

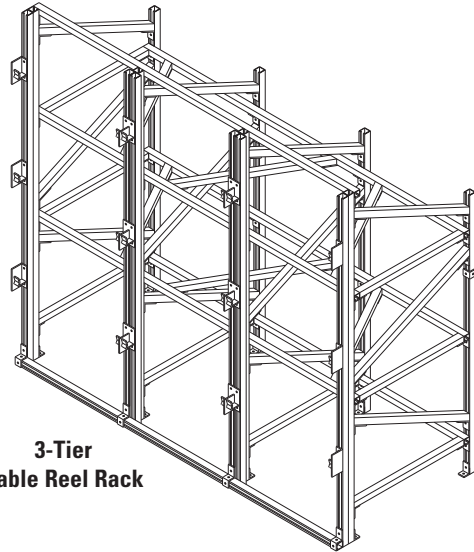

**3-Tier
Cable Reel Rack**

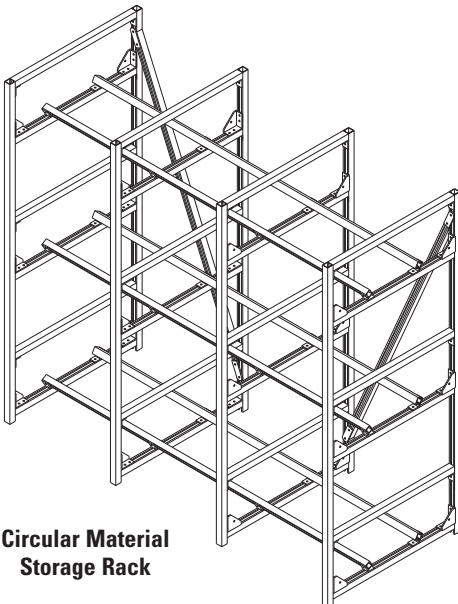

**Circular Material
Storage Rack**

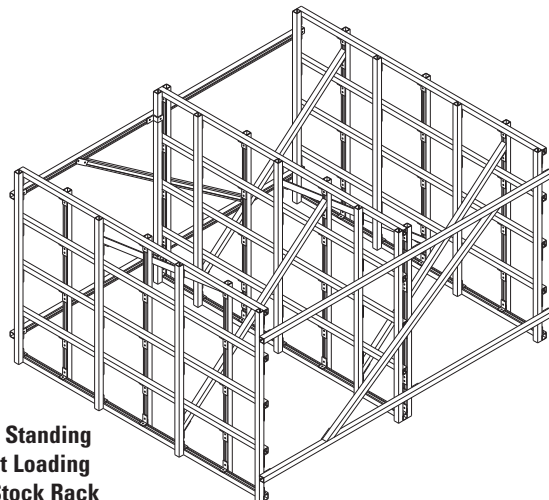

**Free Standing
Front Loading
Bar Stock Rack**

Typical Strut Applications

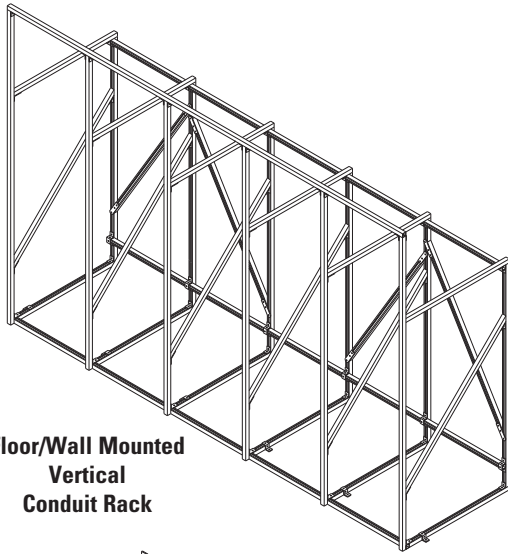

**Floor/Wall Mounted
Vertical
Conduit Rack**

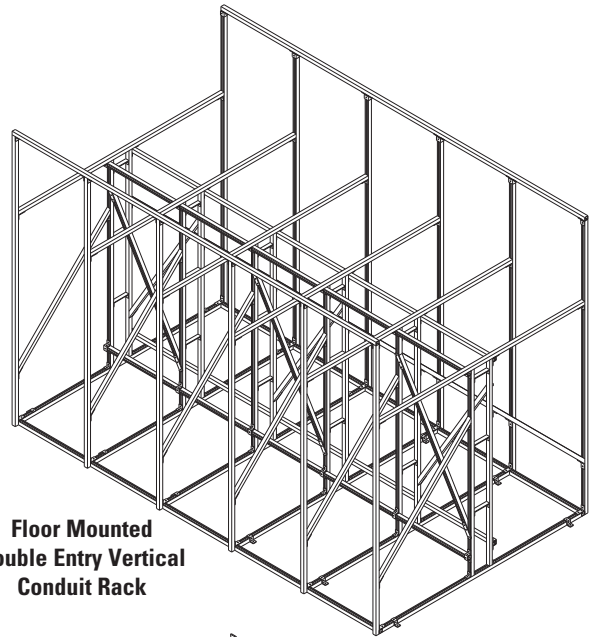

**Floor Mounted
Double Entry Vertical
Conduit Rack**

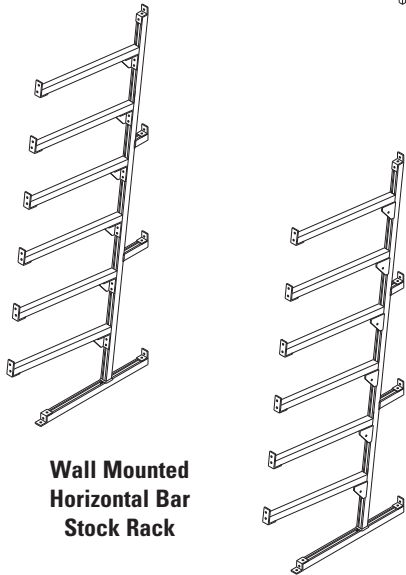

**Wall Mounted
Horizontal Bar
Stock Rack**

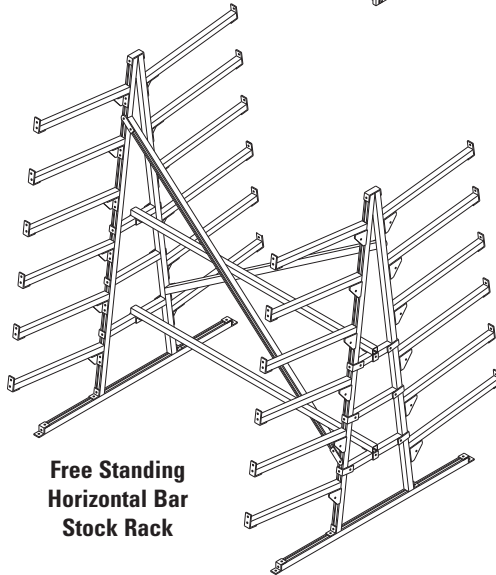

**Free Standing
Horizontal Bar
Stock Rack**

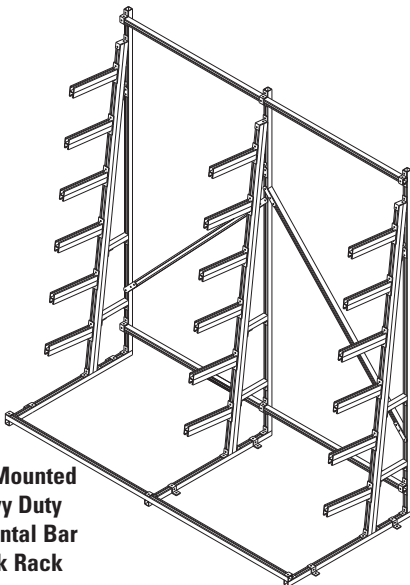

**Wall Mounted
Heavy Duty
Horizontal Bar
Stock Rack**



**Free Standing
Double Entry Heavy Duty
Horizontal Bar
Stock Rack**

Typical Strut Applications

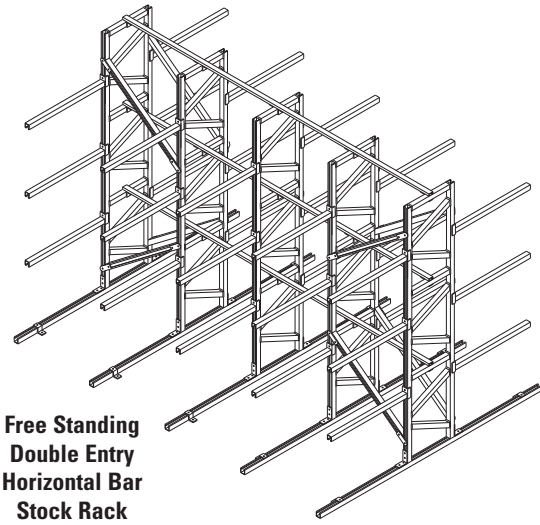

**Free Standing
Double Entry
Horizontal Bar
Stock Rack**

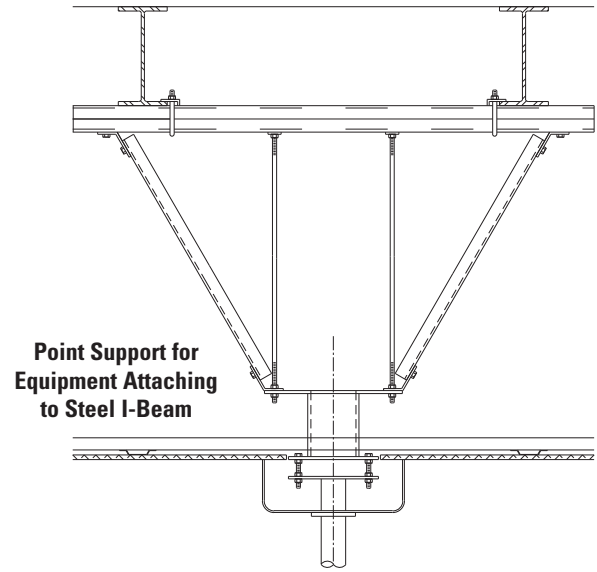

**Point Support for
Equipment Attaching
to Steel I-Beam**

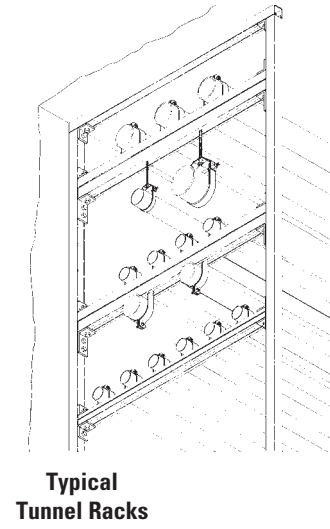
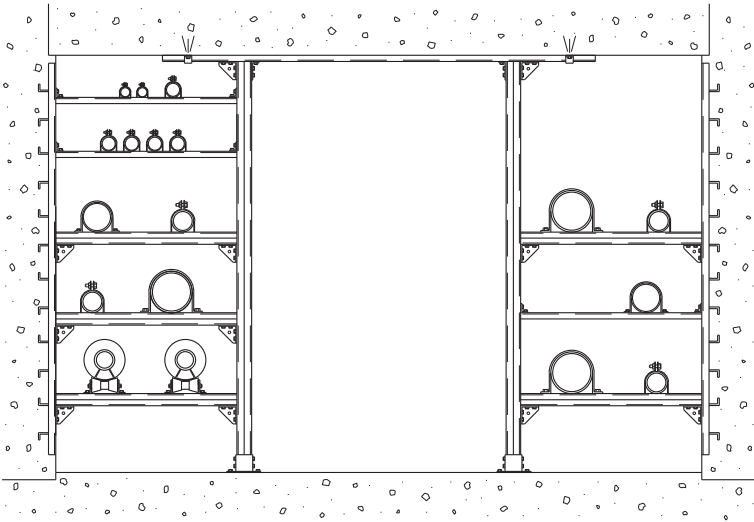

**Typical
Tunnel Racks**

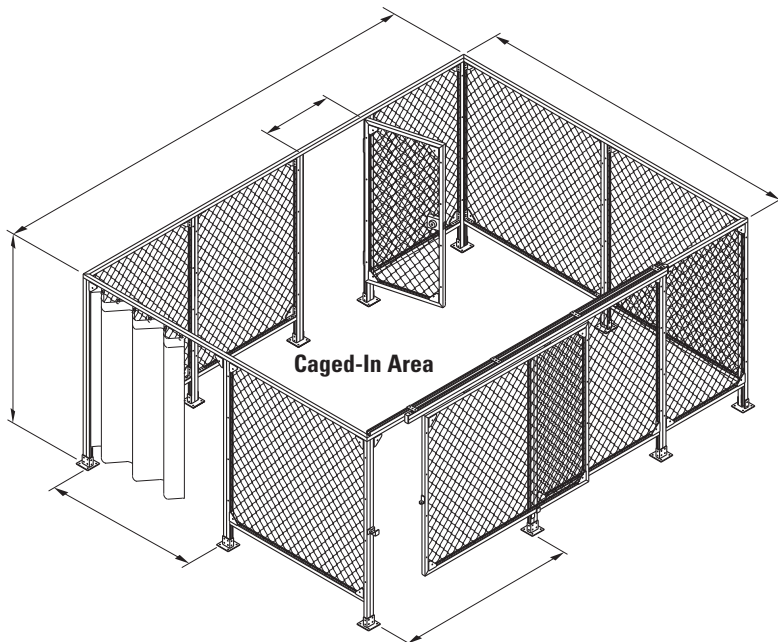

Caged-In Area

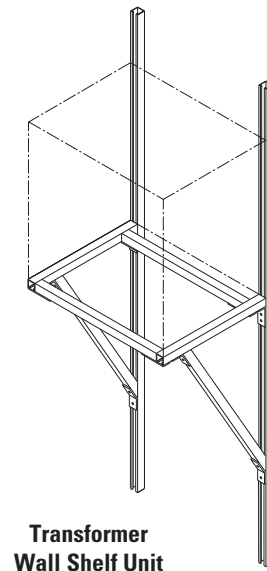

**Transformer
Wall Shelf Unit**

Typical Strut Applications

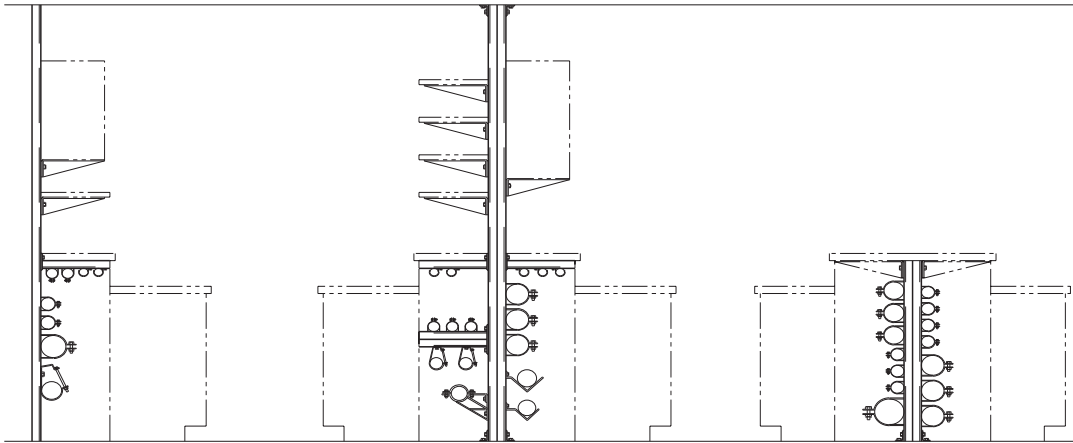

Typical Pipe Chases & Laboratory Furniture Assembly

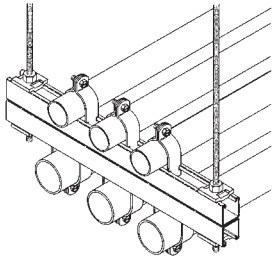

Pipe & Conduit Trapeze

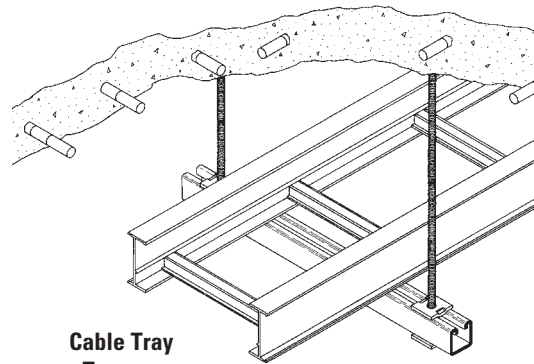

Cable Tray Trapeze

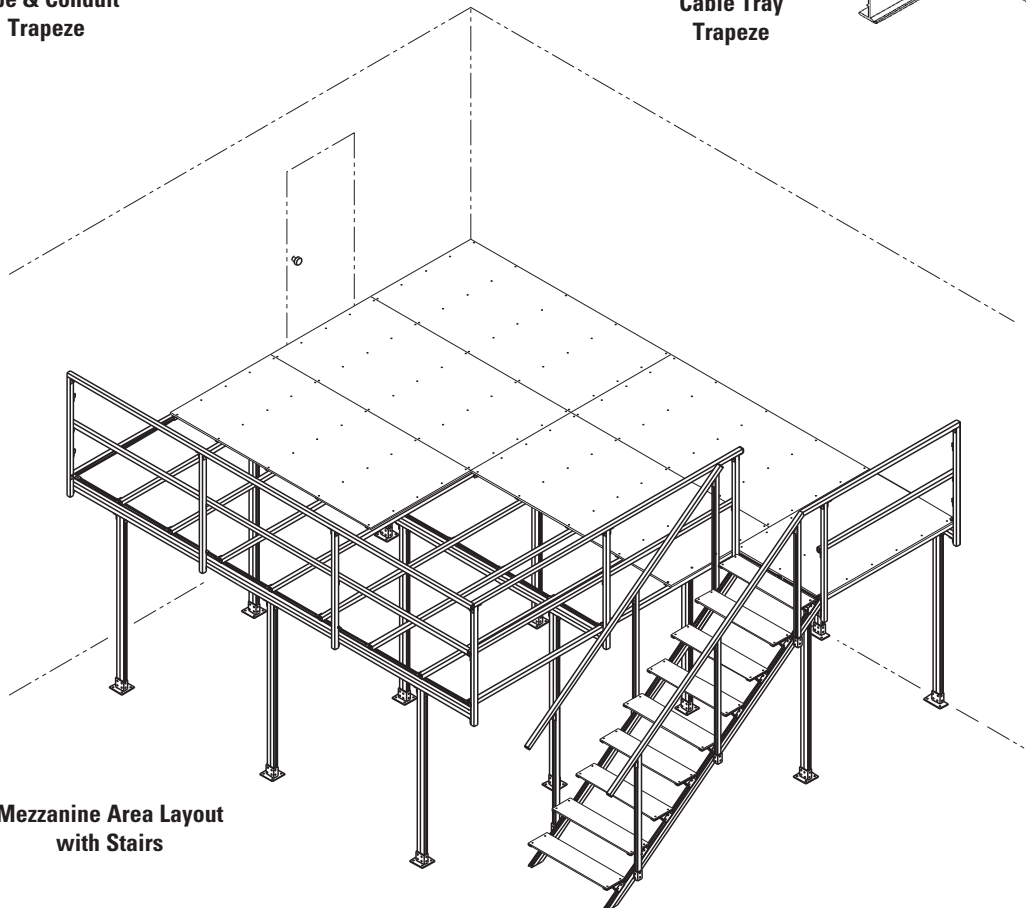

Mezzanine Area Layout with Stairs

Typical Strut Applications

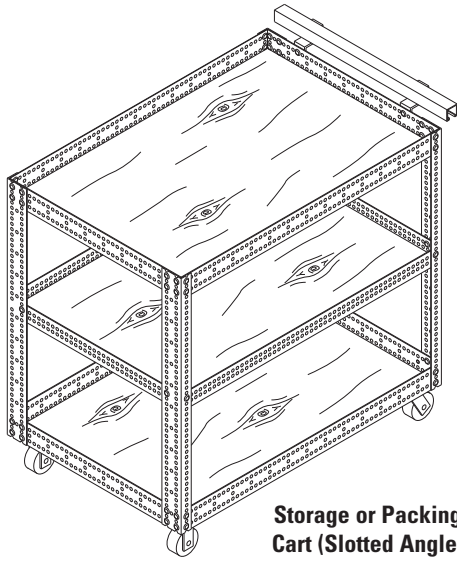

**Storage or Packing
Cart (Slotted Angle)**

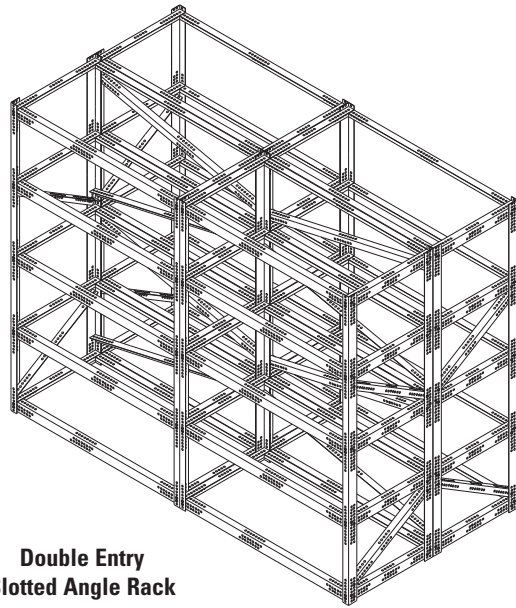

**Double Entry
Slotted Angle Rack**

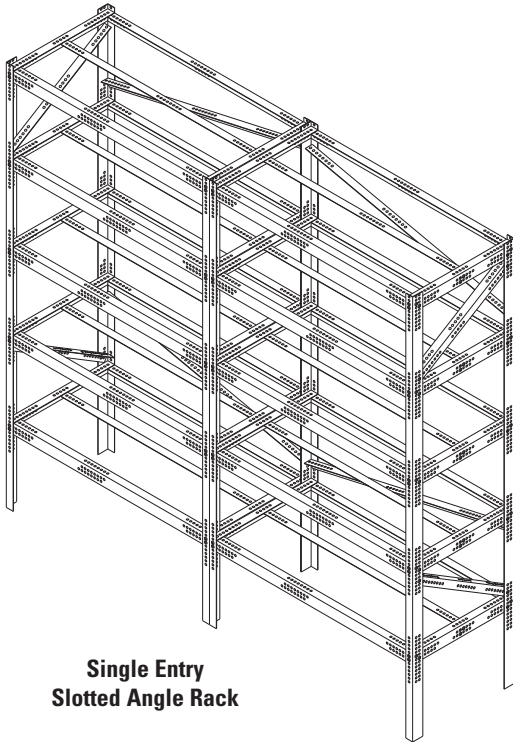

**Single Entry
Slotted Angle Rack**

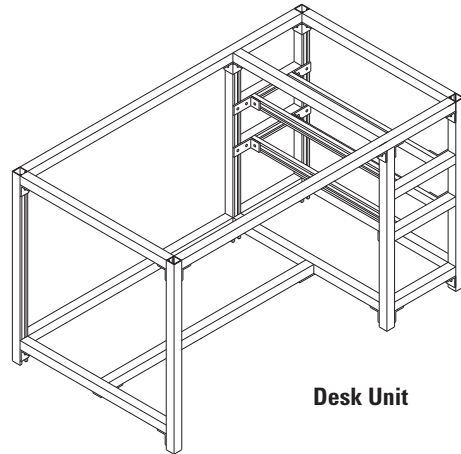

Desk Unit

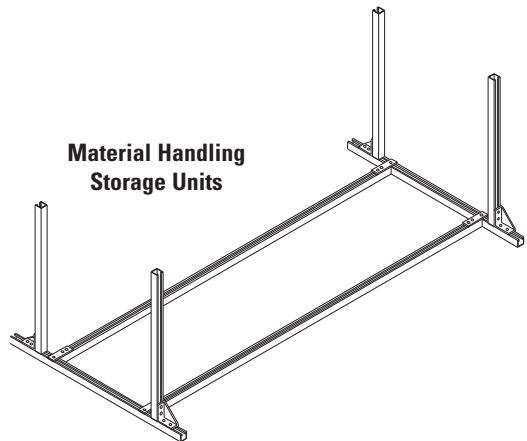

**Material Handling
Storage Units**

Eaton's B-Line Division reserves the right to make changes to the specifications, materials, equipment, prices, or the availability of products at any time without prior notice. While every effort has been made to assure the accuracy of information contained in this catalog at the time of publication, we cannot accept responsibility for inaccuracies resulting from undetected errors or omissions.

U.S. Customer Service Center is staffed Monday through Friday
from 7 a.m. to 5:00 p.m. Central Standard Time.

For more information, visit
Eaton.com/strutsystems.

**Eaton's B-Line Business
United States**

509 West Monroe Street
Highland, IL 62249
United States
Phone: (800) 851-7415

**Eaton's B-Line Business
Australia**

205-209 Woodpark Road
Smithfield, NSW 2164
Australia
Phone: + 61 2 8575 8008

**Eaton's B-Line Business
Canada**

5925 McLaughlin Road
Mississauga, ON L5R 1B8
Canada
Phone: (800) 569-3660

**Eaton
Cooper Industries
Middle East**

77 Cross 20 Street, Dammam 2nd Industrial City
PO Box 70160 - Al Khobar - 31952
Kingdom of Saudi Arabia
Phone: 00966 13 812 2236